

# ELM604PA 1.4MHz, 800mA dual PWM step-down converter

<https://www.elm-tech.com>

## ■ General description

ELM604PA consists of dual high efficiency PWM step-down DC/DC converters operated with current mode and constant frequency. For each converter the integration of a main switch and a synchronous rectifier eliminates the use of an external Schottky diode. ELM604PA is ideal for the application of portable electronic devices with a single cell Lithium-ion (Li+) battery. Each converter can supply 800mA of load current from a 2.5V to 6V input voltage. The output voltage can be regulated as low as 0.6V. It can also run at 100% duty cycle for low dropout applications.

## ■ Features

- Current mode operation
- Thermal shutdown protection
- Short circuit protection
- Constant frequency operation : Typ.1.4MHz
- Output current : 800mA(on each channel)
- Low output voltage : 0.6V
- High efficiency : Max.95%
- Shutdown current : Typ.0.1μA
- Supply voltage : 2.5V to 6.0V
- Full duty ratio : 0 to 100% (in dropout)
- Package : TDFN10-3x3

## ■ Application

- PDAs
- MP3 players
- Portable instruments
- Cellular and smart phones
- Digital still and video cameras
- Microprocessors and DSP core supplies

## ■ Maximum absolute ratings

Parameter	Symbol	Limit	Unit
VIN1/VIN2 power supply voltage	V <sub>in</sub>	-0.3 to +6.5	V
Apply voltage to SW1/SW2	V <sub>sw</sub>	-0.3 to V <sub>in</sub> +0.3	V
Apply voltage to FB1/FB2	V <sub>fb</sub>	-0.3 to V <sub>in1</sub> /V <sub>in2</sub>	V
Apply voltage to EN1/EN2	V <sub>en</sub>	-0.3 to V <sub>in1</sub> /V <sub>in2</sub>	V
Operating temperature range	T <sub>op</sub>	-40 to +85	°C
Storage temperature range	T <sub>stg</sub>	-65 to +150	°C

Caution:Permanent damage to the device may occur when ratings above maximum absolute ones are used.

## ■ Selection guide

### ELM604PA-N

Symbol	Parameter	Value
a	Package	P: TDFN10-3x3
b	Product version	A
c	Taping direction	N: Refer to PKG file

ELM604PA - N  
 ↑↑ ↑  
 a b c

\* Taping direction is one way.

# ELM604PA 1.4MHz, 800mA dual PWM step-down converter

<https://www.elm-tech.com>

## ■ Pin configuration

TDFN10-3x3(TOP VIEW)

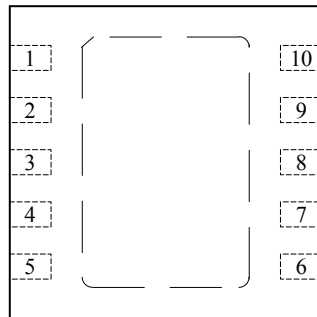

TDFN10-3x3(BOTTOM VIEW)

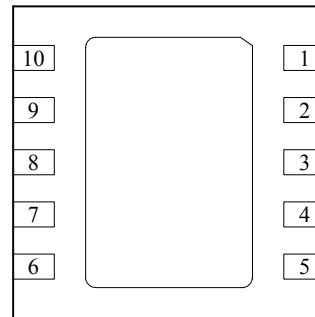

Pin No.	Pin name	Pin description
1	EN1	Channel 1 enable control input
2	FB1	Channel 1 voltage feedback
3	VIN2	Channel 2 supply input
4	GND2	Channel 2 ground pin
5	SW2	Channel 2 power switch output
6	EN2	Channel 2 enable control input
7	FB2	Channel 2 voltage feedback
8	VIN1	Channel 1 supply input
9	GND1	Channel 1 ground pin
10	SW1	Channel 1 power switch output

## ■ Standard circuit

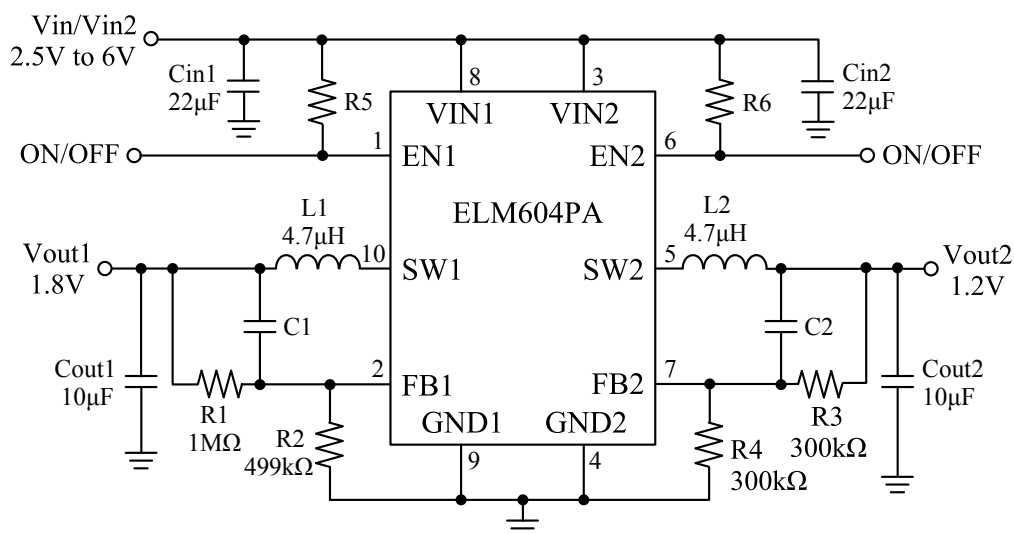

\* Passive components not specified values in the above figure are optional.

# ELM604PA 1.4MHz, 800mA dual PWM step-down converter

<https://www.elm-tech.com>

## ■Block diagram

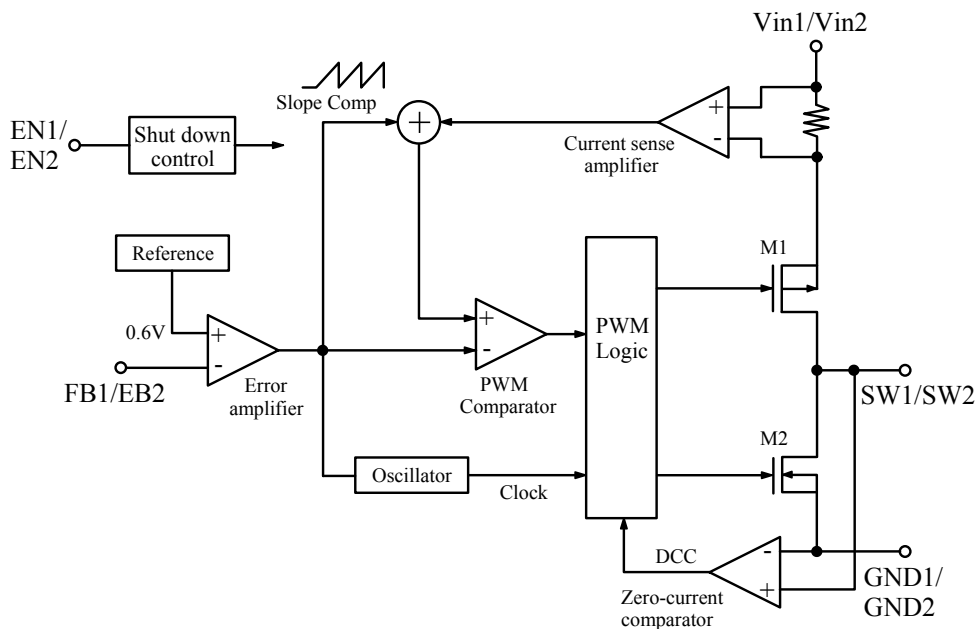

## ■Electrical characteristics

$V_{in}=3.6V$ , Typical values are at  $T_{op}=25^{\circ}C$ , unless otherwise noted.

Parameter	Symbol	Test condition	Min.	Typ.	Max.	Unit
Supply voltage	$V_{in}$		2.5		6.0	V
Feedback current	$I_{fb}$		-30.0	0.5	30.0	nA
Regulated feedback voltage	$V_{fb}$	$-40^{\circ}C \leq T_{op} \leq +85^{\circ}C$	0.582	0.600	0.618	V
Reference voltage line regulation	$\Delta V_{fb}$	$V_{in}=2.5V$ to $6V$		0.04	0.40	%/V
Output voltage line regulation	$\Delta V_{out}$	$V_{in}=2.5V$ to $6V$		0.04	0.40	%/V
Output voltage load regulation	$V_{lr}$			0.5		%
Shutdown current	$I_s$	$V_{en}=0V$ , $V_{in}=6V$		0.01	1.00	$\mu A$
Quiescent current	$I_q$	$V_{en}=V_{in}$ , $V_{fb}=0.65V$ No switching		200		$\mu A$
SW leakage current	$I_{leak}$	$V_{en}=0V$ , $V_{fb}=0.65V$ $V_{sw}=0V$ or $6V$	-1		1	$\mu A$
PMOSFET on resistance	$R_{dsonP}$	$I_{sw}=100mA$		0.35		$\Omega$
NMOSFET on resistance	$R_{dsonN}$	$I_{sw}=-100mA$		0.24		$\Omega$
PMOSFET current limit	$I_{Pcl}$	Duty cycle=100% Current pulse width<1ms	0.8	1.1	1.5	A
Oscillator frequency	$F_{osc}$		1.12	1.40	1.68	MHz
Thermal shutdown threshold	$T_s$			145		$^{\circ}C$
EN high level input voltage	$V_{enh}$	$-40^{\circ}C \leq T_{op} \leq +85^{\circ}C$	-1.1			V
EN low level input voltage	$V_{enl}$	$-40^{\circ}C \leq T_{op} \leq +85^{\circ}C$			0.3	V
EN input current	$I_{en}$	$V_{en}=0V$ to $V_{in}$	-1		1	$\mu A$

# ELM604PA 1.4MHz, 800mA dual PWM step-down converter

<https://www.elm-tech.com>

## ■Application notes

ELM604PA has dual independent constant frequency current mode PWM step-down converters. ELM604PA is optimized for low voltage, Li-ion battery powered applications where high efficiency and small size are critical. ELM604PA uses external resistor dividers to set two output voltages independently from 0.6V to 6V. The device integrates both main switches and synchronous rectifiers, which provides high efficiency and eliminates the need for an external Schottky diode. ELM604PA can achieve 100% duty cycle. The duty cycle D of each step-down converter is defined as:

$$D = T_{on} \times F_{osc} \times 100\% \approx (V_{out}/V_{in}) \times 100\%$$

Where  $T_{on}$  is the main switch on time,  $F_{osc}$  is the oscillator frequency (1.4MHz),  $V_{out}$  is the output voltage and  $V_{in}$  is the input voltage.

### 1) Current mode PWM Control

Slope compensated current mode PWM control provides stable switching and cycle-by-cycle current limit for superior load and line response and protection of the internal main switch and synchronous rectifier. Each channel switches at a constant frequency (1.4MHz) and regulates the output voltage. During each cycle the PWM comparator modulates the power transferred to the load by changing the inductor peak current based on the feedback error voltage. During normal operation, the main switch is turned on for a certain time to ramp the inductor current at each rising edge of the internal oscillator, and switched off when the peak inductor current is above the error voltage. When the main switch is off, the synchronous rectifier will be turned on immediately and stay on until the next cycle starts.

### 2) Dropout operation

Each channel of the ELM604PA allows the main switch to remain on for more than one switching cycle and increases the duty cycle while the input voltage is dropping close to the output voltage. When the duty cycle reaches 100%, the main switch is held on continuously to deliver current to the output up to the P MOSFET current limit. The output voltage then is the input voltage minus the voltage drop across the main switch and the inductor.

### 3) Short circuit protection

ELM604PA has short circuit protection. When the output is shorted to ground, the oscillator frequency is reduced to prevent the inductor current from increasing beyond the P MOSFET current limit. The frequency will return to the normal values once the short circuit condition is removed and the feedback voltage reaches 0.6V.

### 4) Maximum load current

ELM604PA can operate down to 2.5V input voltage, however the maximum load current decreases at lower input due to large IR drop on the main switch and synchronous rectifier. The slope compensation signal reduces the peak inductor current as a function of the duty cycle to prevent sub-harmonic oscillations at duty cycles greater than 50%. Conversely the current limit increases as the duty cycle decreases.

## ■Marking

TDFN10-3x3

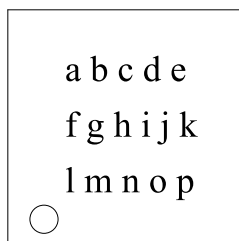

Mark	Content
a to p	Assembly lot No.: 0 to 9 & A to Z

# ELM604PA 1.4MHz, 800mA dual PWM step-down converter

<https://www.elm-tech.com>

## ■ Typical characteristics

- $V_{out}=1.8V$  : Unless otherwise noted  
 $C_{in1}=22\mu F$ ,  $C_{out1}=10\mu F$ ,  $C1=1000pF$ ,  $L1=4.7\mu H$ ,  $R1=100k\Omega$ ,  $R2=50k\Omega$ ,  $T_{op}=25^{\circ}C$

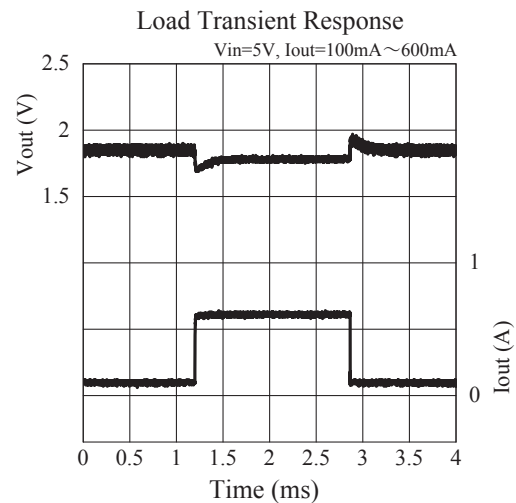
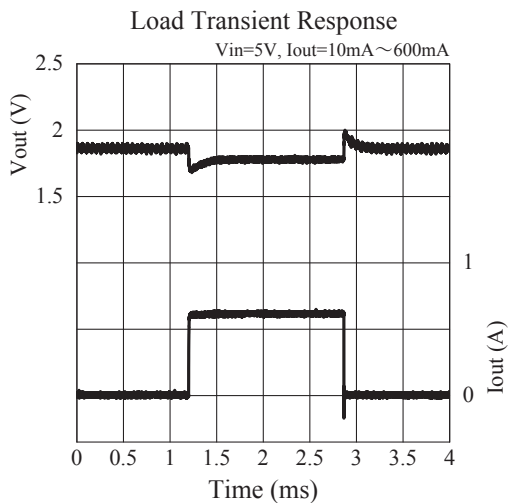
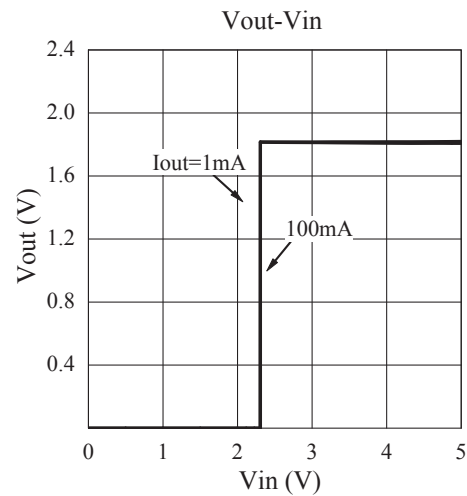
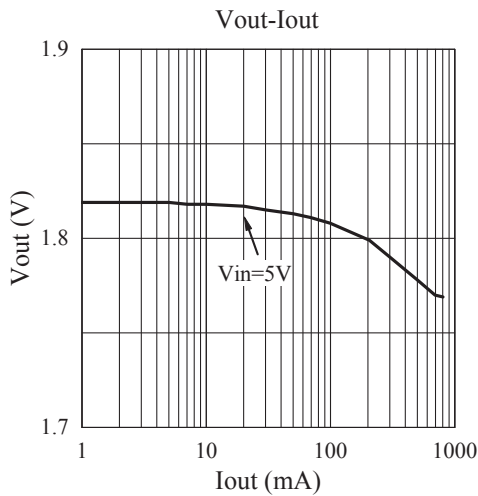
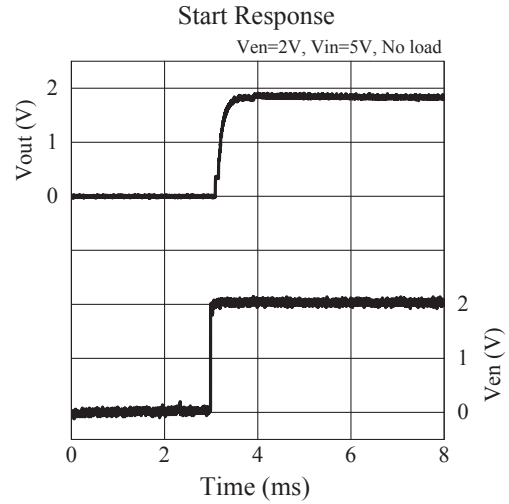
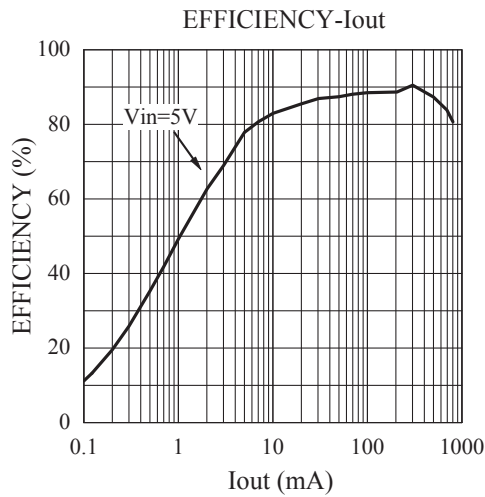

# ELM604PA 1.4MHz, 800mA dual PWM step-down converter

<https://www.elm-tech.com>

- $V_{out}=3.3V$  : Unless otherwise noted  
 $C_{in2}=22\mu F$ ,  $C_{out2}=10\mu F$ ,  $C2=1000pF$ ,  $L2=4.7\mu H$ ,  $R3=150k\Omega$ ,  $R4=33k\Omega$ ,  $T_{op}=25^{\circ}C$

