

ELM614BA 2A, 18V, 500kHz, synchronous step down DC/DC converter

<https://www.elm-tech.com>

■ General description

ELM614BA is a high-frequency, synchronous, rectified, step-down, switch-mode converter with internal power MOSFETs. It offers a very compact solution to achieve a 2A continuous output current over a wide input supply range, with excellent load and line regulation. ELM614BA has synchronous-mode operation for higher efficiency over the output current-load range.

Current-mode operation provides fast transient response and eases loop stabilization. Switching frequency is internally fixed 500kHz, and automatic switchover to PFM control method at light load can achieve high efficiency over the full load range from heavy load to light load.

Protection features include over-current protection and thermal shutdown.

ELM614BA requires a minimal number of readily available, standard external components and is available in space-saving SOT-26 package.

■ Features

- Internal soft start
- Over current and over temperature protection
- Input voltage : 4.5V to 18V
- Output adjustable voltage : 0.8V to 15V
- Output current : 2A
- Integrated power MOSFET switches : 140mΩ/90mΩ
- Shutdown current : Typ 3μA
- High efficiency : Max 95%
- Constant frequency : Typ 500kHz
- Control method : PWM/PFM Automatic switchover
- Package : SOT-26

■ Application

- Distributed power systems
- Networking systems
- FPGA, DSP, ASIC power supplies
- Notebook computers
- Green electronics or appliance

■ Maximum absolute ratings

Parameter	Symbol	Limit	Unit
Supply voltage	V _{in}	-0.3 to +19.0	V
Switch node	V _{sw}	-0.3 to V _{in} +0.3	V
Boost voltage	V _{boot}	V _{sw} -0.3 to V _{sw} +6.0	V
All other pins	V _{all}	-0.3 to +6.0	V
Power dissipation	P _d	1200 ^(*)	mW
Junction temperature	T _j	+150	°C
Operating temperature range	T _{op}	-40 to +85	°C
Storage temperature range	T _{stg}	-65 to +150	°C

* Mounted on glass epoxy board (FR-4). (76.2mm×114.3mm×1.6mm : based on EIJ/JEDEC standard size), 2layers, Cu thickness 70μm, Cu area : top side 20%, back side 100%.

■ Selection guide

ELM614BA-S

Symbol		
a	Package	B: SOT-26
b	Product version	A
c	Taping direction	S: Refer to PKG file

ELM614 B A - S
 ↑ ↑ ↑
 a b c

* Taping direction is one way.

ELM614BA 2A, 18V, 500kHz, synchronous step down DC/DC converter

<https://www.elm-tech.com>

■ Pin configuration

SOT-26(TOP VIEW)

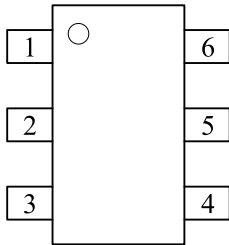

Pin No.	Pin name	Pin description
1	GND	Ground
2	SW	Power switching output
3	VIN	Power input
4	FB	Feedback input
5	EN	Enable input
6	BOOT	High-side gate drive boost input

■ Standard circuit (Adjustable Output Voltage)

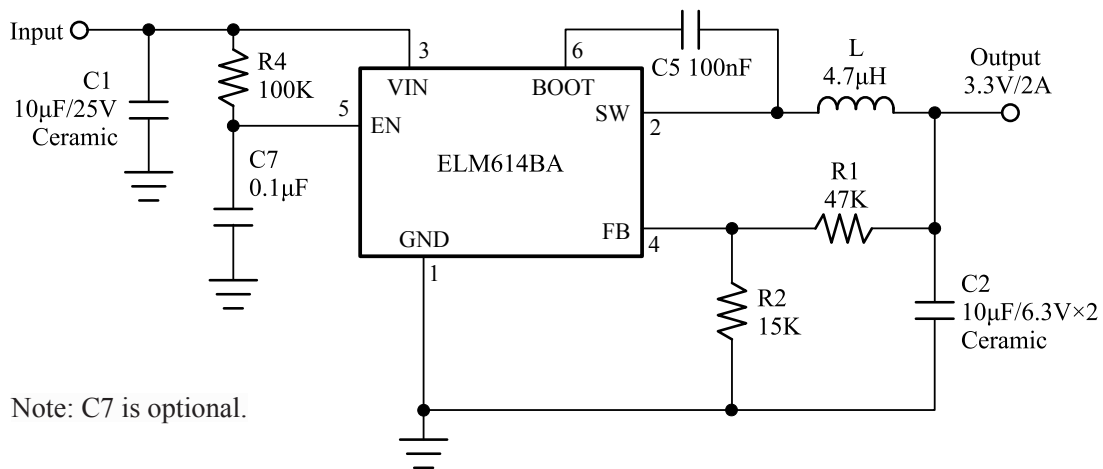

■ Block diagram

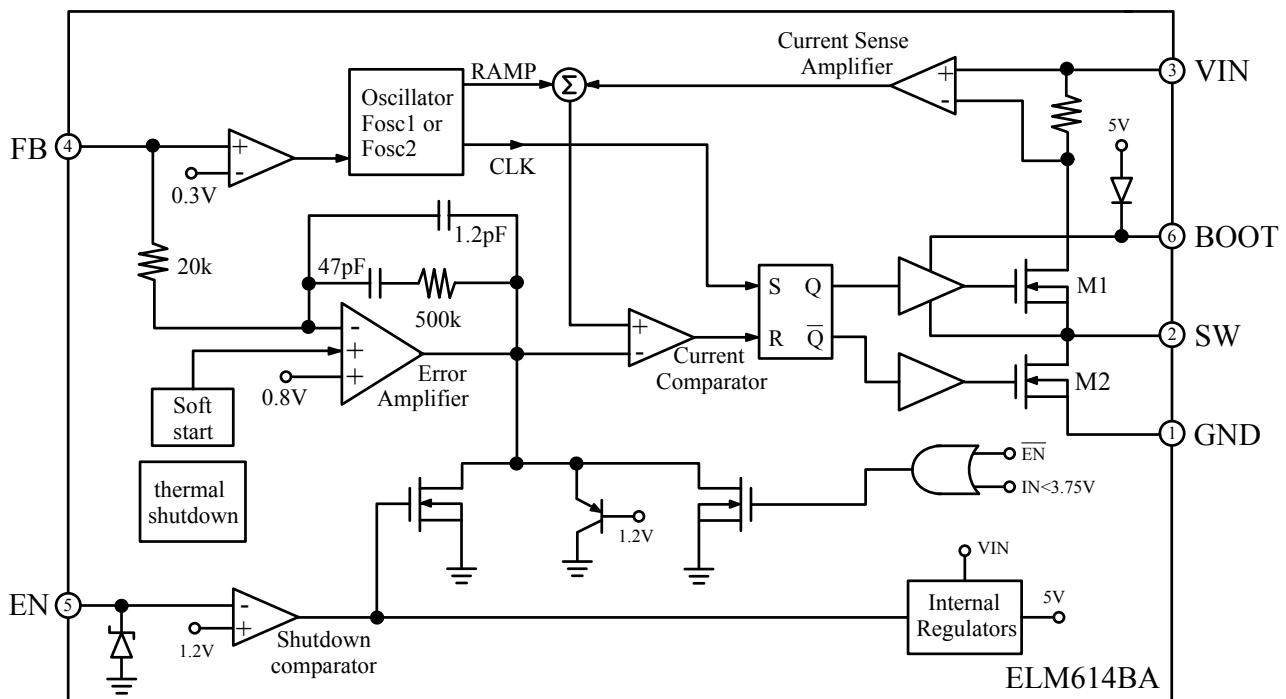

ELM614BA 2A, 18V, 500kHz, synchronous step down DC/DC converter

<https://www.elm-tech.com>

■Electrical characteristics

Vin=+12V, Top=25°C, unless otherwise specified

Parameter	Symbol	Test condition	Min.	Typ.	Max.	Unit
Supply voltage	Vin		4.5		18.0	V
Output voltage	Vout		0.8		15.0	V
Shutdown supply current	Is	Ven=0V		3	6	μA
Supply current	Iin	Ven=2.0V		0.7		mA
Feedback voltage	Vfb	4.5V ≤ Vin ≤ 18.0V	0.784	0.800	0.816	V
Error amplifier voltage gain *	Aea			1000		V/V
High-side switch-on resistance *	Rds(on)H			140		mΩ
Low-side switch-on resistance *	Rds(on)L			90		mΩ
High-side switch leakage current	Ileak	Ven=0V, Vsw=0V Top=+125°C			10	μA
Upper switch current limit	Iuswl	Minimum duty cycle	3.0	3.6		A
Lower switch current limit	Ilswl	From drain to source		0		A
Oscillation frequency	Fosc1		400	500	600	kHz
Short circuit oscillation frequency	Fosc2	Vfb=0V	100	125	150	kHz
Maximum duty cycle	Dmax	Vfb=0.5V		90		%
Minimum on time *	to_min			120		ns
PFM switchover load current *	Iload_pfm	Vout=3.3V, when standard circuit implemented		40		mA
EN falling threshold voltage	VenL	Ven falling	0.56	1.12		V
EN rising threshold voltage	VenH	Ven rising		1.22	1.83	V
Input under voltage lockout threshold	Vuvlo	Vin rising		3.5		V
Input under voltage lockout threshold hysteresis	Vuvlo_hys			240		mV
Soft-start period	tss			1		ms
Thermal shutdown threshold	Tsd			150		°C

* Guaranteed by design, not tested.

■Marking

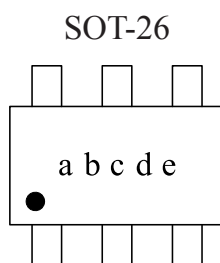

Mark	Content
a to e	Assembly lot No. : 0 to 9 and A to Z

ELM614BA 2A, 18V, 500kHz, synchronous step down DC/DC converter

<https://www.elm-tech.com>

■ Application notes

ELM614BA is a synchronous rectified, current-mode, step-down regulator. It regulates input voltages from 4.5V to 18V down to an output voltage as low as 0.8V, and supplies up to 2A of load current.

ELM614BA uses current-mode control to regulate the output voltage. The output voltage is measured at FB through a resistive voltage divider and amplified through the internal trans-conductance error amplifier.

The converter uses internal N-channel MOSFET switches to step-down the input voltage to the regulated output voltage. Since the high side MOSFET requires a gate voltage greater than the input voltage, a boost capacitor connected between SW and BOOT is needed to drive the high side gate. The boost capacitor is charged from the internal 5V rail when SW is low.

1) Pins description

BOOT: High-side gate drive boost input.

BOOT supplies the drive for the high-side N-channel MOSFET switch. Connect a 0.1μF or greater capacitor from SW to BOOT to power the high side switch.

VIN: Power Input.

VIN supplies the power to the IC, as well as the step-down converter switches. Drive VIN with a 4.5V to 18V power source. Bypass VIN to GND with a suitably large capacitor to eliminate noise on the input to the IC.

SW: Power switching output.

SW is the switching node that supplies power to the output. Connect the output LC filter from SW to the output load. Note that a capacitor is required from SW to BOOT to power the high-side switch.

GND: Ground.

FB: Feedback Input.

FB senses the output voltage to regulate that voltage. Drive FB with a resistive voltage divider from the output voltage. The feedback threshold is 0.8V.

EN: Enable Input.

EN is a digital input that turns the regulator on or off. Drive EN high to turn on the regulator, drive it low to turn it off. Pull up with 100kΩ resistor for automatic startup.

*)EN terminal voltage is clamped to 5.7V by internal zenar diode when pulled up by 100kΩ resistor.

2) Setting the output voltage

The external resistor divider sets the output voltage. The feedback resistor R1 also sets the feedback-loop bandwidth through the internal compensation capacitor (see the Standard circuit and block). Choosing R1 first, R2 is given by:

$$R2 = R1 / (V_{out} / 0.8V - 1)$$

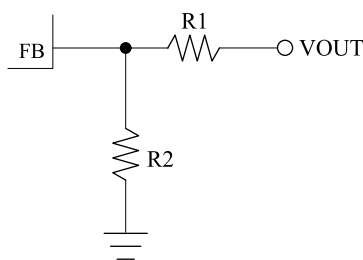

Figure 1: Network.

ELM614BA 2A, 18V, 500kHz, synchronous step down DC/DC converter

<https://www.elm-tech.com>

Table 1 lists the recommended resistors value for common output voltages.

Vout(V)	R1(KΩ)	R2(KΩ)
1.05	103.8(1%)	332.1(1%)
1.20	100.0(1%)	200.1(1%)
1.80	85.0(1%)	68.0(1%)
2.50	67.5(1%)	31.8(1%)
3.30	47.5(1%)	15.2(1%)
5.00	83.1(1%)	15.8(1%)

Table 1 : Resistor selection for common output voltages.

3) Inductor

The inductor is required to supply constant current to the output load while being driven by the switched input voltage. A larger value inductor will result in less ripple current that will result in lower output ripple voltage. However, the larger value inductor will have a larger physical size, higher series resistance, and/or lower saturation current. A good rule for determining the inductance to use is to allow the peak-to-peak ripple current in the inductor to be approximately 30% of the maximum switch current limit. Also, make sure that the peak inductor current is below the maximum switch current limit. The inductance value can be calculated by:

$$L = [V_{out} / (f_s \times \Delta I_L)] \times (1 - V_{out} / V_{in})$$

Where V_{out} is the output voltage, V_{in} is the input voltage, f_s is the switching frequency, and ΔI_L is the peak-to-peak inductor ripple current. Choose an inductor that will not saturate under the maximum inductor peak current. The peak inductor current can be calculated by:

$$I_{lp} = I_{load} + [V_{out} / (2 \times f_s \times L)] \times (1 - V_{out} / V_{in})$$

Where I_{load} is the load current.

The choice of which style inductor to use mainly depends on the price vs. size requirements and any EMI requirements.

4) Optional schottky diode

During the transition between high-side switch and low-side switch, the body diode of the low-side power MOSFET conducts the inductor current. The forward voltage of this body diode is high. An optional Schottky diode may be paralleled between the SW pin and GND pin to improve overall efficiency. Table 2 lists example Schottky diodes and their Manufacturers.

Part number	Voltage and Current Rating	Vendor
B130	30V, 1A	Diodes Inc.
SK13	30V, 1A	Diodes Inc.
MBRS130	30V, 1A	International Rectifier

Table 2 : Diode selection guide.

5) Input capacitor

The input current to the step-down converter is discontinuous, therefore a capacitor is required to supply the AC current to the step-down converter while maintaining the DC input voltage. Use low ESR capacitors for the best performance. Ceramic capacitors are preferred, but tantalum or low-ESR electrolytic capacitors may also suffice. Choose X5R or X7R dielectrics when using ceramic capacitors.

ELM614BA 2A, 18V, 500kHz, synchronous step down DC/DC converter

<https://www.elm-tech.com>

Since the input capacitor (C1) absorbs the input switching current it requires an adequate ripple current rating. The RMS current in the input capacitor can be estimated by:

$$I_{c1} = I_{load} \times [(V_{out} / V_{in}) \times (1 - V_{out} / V_{in})]^{1/2}$$

The worst-case condition occurs at $V_{in} = 2V_{out}$, where $I_{c1} = I_{load}/2$. For simplification, choose the input capacitor whose RMS current rating greater than half of the maximum load current. The input capacitor can be electrolytic, tantalum or ceramic. When using electrolytic or tantalum capacitors, a small, high quality ceramic capacitor, i.e. 0.1 μ F, should be placed as close to the IC as possible. When using ceramic capacitors, make sure that they have enough capacitance to provide sufficient charge to prevent excessive voltage ripple at input. The input voltage ripple for low ESR capacitors can be estimated by:

$$\Delta V_{in} = [I_{load} / (C1 \times f_s)] \times (V_{out} / V_{in}) \times (1 - V_{out} / V_{in})$$

Where C1 is the input capacitance value.

6) Output capacitor

The output capacitor is required to maintain the DC output voltage. Ceramic, tantalum, or low ESR electrolytic capacitors are recommended. Low ESR capacitors are preferred to keep the output voltage ripple low. The output voltage ripple can be estimated by:

$$\Delta V_{out} = [V_{out} / (f_s \times L)] \times (1 - V_{out} / V_{in}) \times [R_{esr} + 1 / (8 \times f_s \times C2)]$$

Where C2 is the output capacitance value and R_{esr} is the equivalent series resistance (ESR) value of the output capacitor.

In the case of ceramic capacitors, the impedance at the switching frequency is dominated by the capacitance. The output voltage ripple is mainly caused by the capacitance. For simplification, the output voltage ripple can be estimated by:

$$\Delta V_{out} = [V_{out} / (8 \times f_s^2 \times L \times C2)] \times (1 - V_{out} / V_{in})$$

In the case of tantalum or electrolytic capacitors, the ESR dominates the impedance at the switching frequency. For simplification, the output ripple can be approximated to:

$$\Delta V_{out} = [V_{out} / (f_s \times L)] \times (1 - V_{out} / V_{in}) \times R_{esr}$$

The characteristics of the output capacitor also affect the stability of the regulation system. ELM614BA can be optimized for a wide range of capacitance and ESR values.

7) External bootstrap diode

An external bootstrap diode may enhance the efficiency of the regulator, the applicable conditions of external BOOT diode are:

- $V_{out} = 5V$ or $3.3V$; and
- Duty cycle is high : $D = V_{out} / V_{in} > 65\%$

In these cases, an external BOOT diode is recommended from the output of the voltage regulator to BOOT pin, as shown in Figure 2.

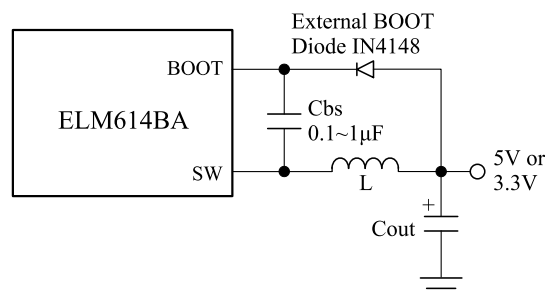

Figure 2: Add optional external bootstrap diode to enhance efficiency.

ELM614BA 2A, 18V, 500kHz, synchronous step down DC/DC converter

<https://www.elm-tech.com>

The recommended external BOOT diode is IN4148, and the BOOT capacitor is 0.1 ~ 1μF.

When $V_{in} \leq 6V$, for the purpose of promote the efficiency, it can add an external Schottky diode between VIN and BOOT pins, as shown in Figure 3.

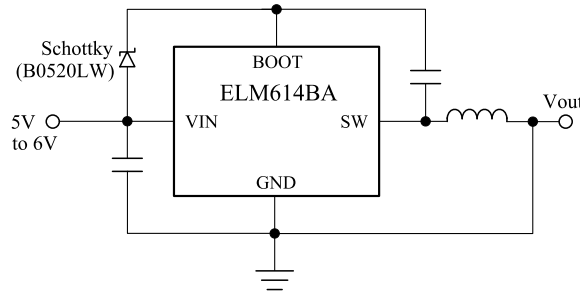

Figure 3: Add a Schottky diode to promote efficiency when $V_{in} \leq 6V$.

8) PCB layout guide

PCB layout is very important to achieve stable operation. Please follow the guidelines below.

- 1) Keep the path of switching current short and minimize the loop area formed by Input capacitor, high-side MOSFET and low-side MOSFET.
- 2) Bypass ceramic capacitors are suggested to be put close to the VIN Pin.
- 3) Ensure all feedback connections are short and direct. Place the feedback resistors as close to the chip as possible.
- 4) Route SW away from sensitive analog areas such as FB.
- 5) Connect VIN, SW, and especially GND respectively to a large copper area to cool the chip to improve thermal performance and long-term reliability.

9) BOM of ELM614BA

Please refer to the Standard circuit.

Item	Reference	Part
1	C1	10μF
2	C5	100nF
3	C7	0.1μF
4	R4	100K

Table 3: BOM selection table I.

	L	R1	R2	C2
Vout = 5.0V	6.8μH	83.1K	15.8K	10μF×2
Vout = 3.3V	4.7μH	47.5K	15.2K	10μF×2
Vout = 2.5V	3.3μH	67.5K	31.8K	10μF×2
Vout = 1.8V	2.2μH	85.0K	68.0K	10μF×2
Vout = 1.2V	2.2μH	100.0K	200.1K	10μF×2

Table 4: BOM selection table II.

ELM614BA 2A, 18V, 500kHz, synchronous step down DC/DC converter

<https://www.elm-tech.com>

■ Typical characteristics

$V_{in}=12V$, $V_{out}=3.3V$, $L=4.7\mu H$, $C1=10\mu F$, $C2=10\mu F \times 2$, $T_{op}=+25^{\circ}C$, unless otherwise noted.

Start Up (12V=>3.3V, Load=2A)

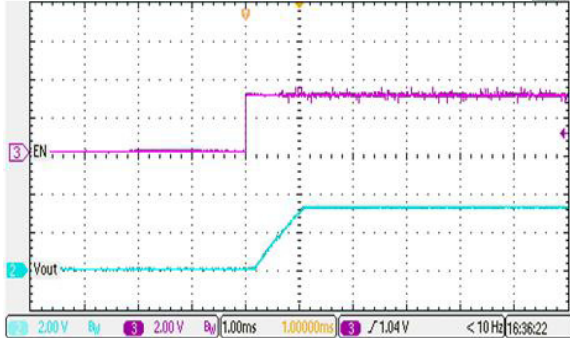

Shut Down (12V=>3.3V, Load=2A)

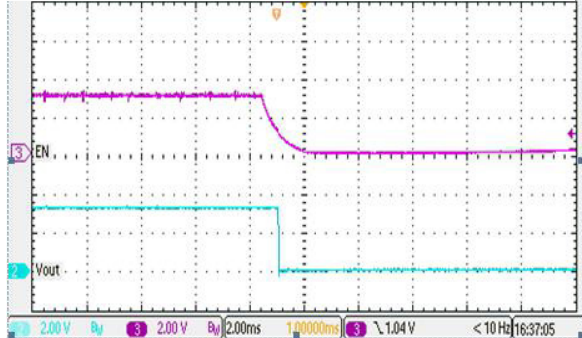

Output Rippie (12V=>3.3V, Load=2A)

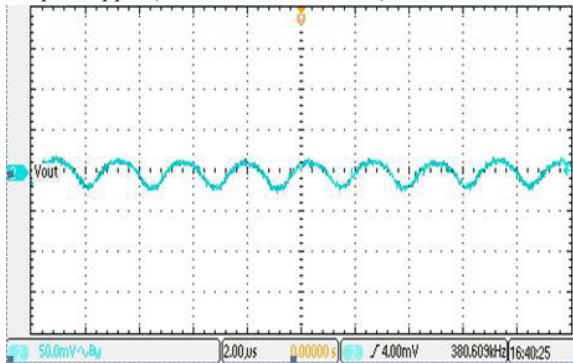

Output Rippie (12V=>3.3V, Load=1A)

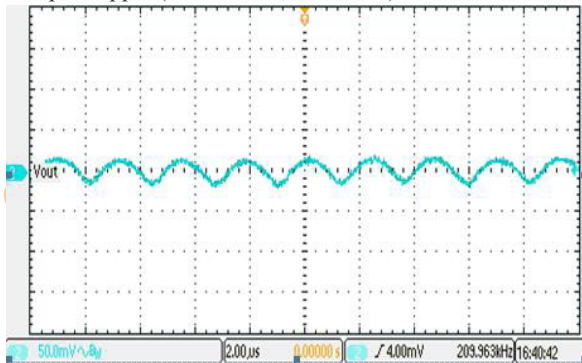

Output Rippie (12V=>3.3V, Load=0A)

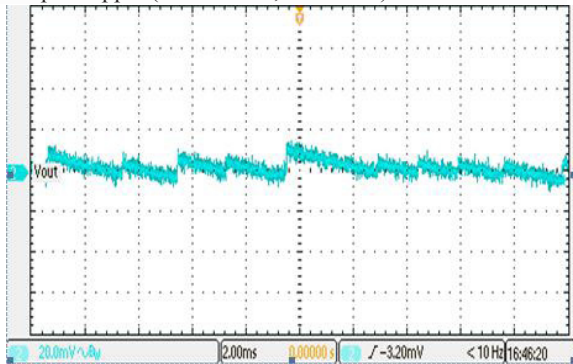

Dynamic Load (Iload=0.2A_2A, Vout=3.3V)

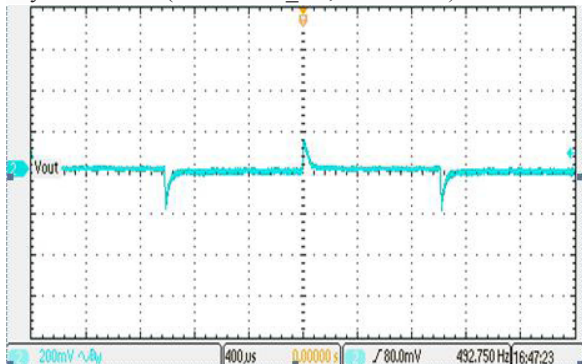

Short Circuit Protection

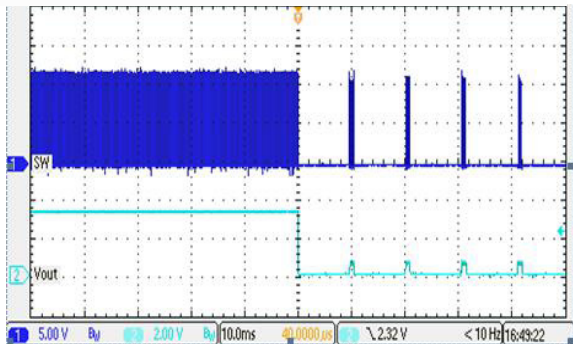

Efficiency

