

# ELM620BA 1.4MHz

## high efficiency synchronous PWM step up DC/DC converter

https://www.elm-tech.com

### ■General description

ELM620BA is synchronous PWM step-up DC/DC converter with high efficiency and 1.4MHz fixed frequency; by adopting synchronous switch, ELM620BA is able to provide high efficiency without external Schottky diode. ELM620BA is able to activate within the range from 0.6V to 5V of input voltage and 2.5V to 6V of output one.

For 3V or 3.3V output, ELM620BA can provide current up to 260mA by a single AA cell, or to 600mA by 2 serial-connected AA cells.

With 1.4MHz switching frequency, small coils and capacitors can be adopted; therefore, ELM620BA is possible to be assembled within small areas on the board .

### ■Features

- Current mode control
- Output voltage drop protection
- Thermal shutdown protection and short circuit protection
- Input voltage : 0.6V to 5.0V
- Output voltage : 2.5V to 6.0V
- Low current consumption : Typ.300 $\mu$ A
- Shutdown current : < 1 $\mu$ A
- Low start-up voltage : Typ.0.9V
- Low switch on (internal switch) resistance : 0.35 $\Omega$
- Constant frequency : Typ.1.4MHz
- High efficiency : 96%
- Package : SOT-26

### ■Application

- Cellular phone
- Digital camera
- MP3 player
- Portable machine
- Wireless handset

### ■Maximum absolute ratings

Parameter	Symbol	Limit	Unit
VIN power supply voltage	Vin	-0.3 to +6.0	V
Apply voltage to SW	Vsw	GND-0.3 to Vout+0.3	V
Apply voltage to FB	Vfb	GND-0.3 to Vout+0.3	V
Apply voltage to EN	Ven	GND-0.3 to Vout+0.3	V
Apply voltage to VOUT	Vout	-0.3 to +6.0	V
Power dissipation	Pd	250	mW
Operating temperature range	Top	-30 to +85	°C
Storage temperature range	Tstg	-65 to 125	°C

Caution:Permanent damage to the device may occur when ratings above maximum absolute ones are used.

### ■Selection guide

#### ELM620BA-S

Symbol		
a	Package	B: SOT-26
b	Product version	A
c	Taping direction	S: Refer to PKG file

ELM620BA - S  
↑↑↑  
a b c

\* Taping direction is one way.

# ELM620BA 1.4MHz

## high efficiency synchronous PWM step up DC/DC converter

<https://www.elm-tech.com>

### ■ Pin configuration

SOT-26(TOP VIEW)

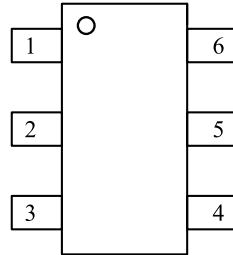

Pin No.	Pin name	Pin description
1	SW	Switch
2	GND	Ground
3	FB	Feedback
4	EN	ON/OFF control (High enable)
5	VOUT	Output
6	VIN	Input

### ■ Pin assignment

1) SW (Pin 1) : Switch pin.

Connect inductor between SW and VIN. Keep these PCB trace lengths as short and wide as possible to reduce EMI and voltage overshoot.

2) GND (Pin 2) : Signal and power ground.

Provide a short direct PCB path between GND and the (–) side of output capacitor(s).

3) FB (Pin 3) : Feedback input to gm error amplifier.

Connect resistor divider tap to this pin. The output voltage can be adjusted from 2.5V to 6V by :

$$V_{out} = 1.203V \times \left(1 + \frac{R1}{R2}\right)$$

4) EN (Pin 4) : Logic controlled shutdown input.

EN = High: Normal free running operation, 1.4MHz typical operating frequency. EN = Low: Shutdown, quiescent current < 1µA. Output capacitor can be completely discharged through the load or feedback resistors.

5) VOUT (Pin 5) : Output voltage sense input and drain of internal synchronous rectifier MOSFET.

Bias is derived from Vout. PCB trace length from Vout to output filter capacitor(s) should be as short and wide as possible.

6) VIN (Pin 6) : Battery input voltage.

The device gets its start-up bias from Vin. Once Vout exceeds Vin, bias comes from Vout. Thus, once operation is started, it is completely independent from Vin and only limited by output power level and battery's internal series resistance.

# ELM620BA 1.4MHz

## high efficiency synchronous PWM step up DC/DC converter

<https://www.elm-tech.com>

### ■ Standard circuit

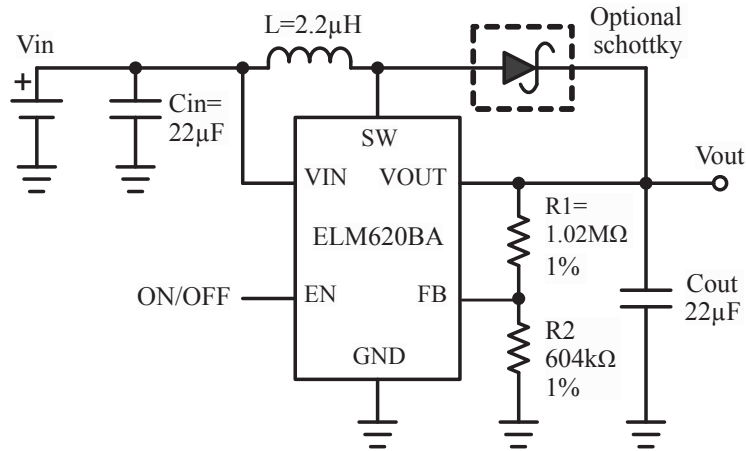

$$V_{out} = \left(1 + \frac{R1}{R2}\right) \times 1.203$$

### ■ Block diagram

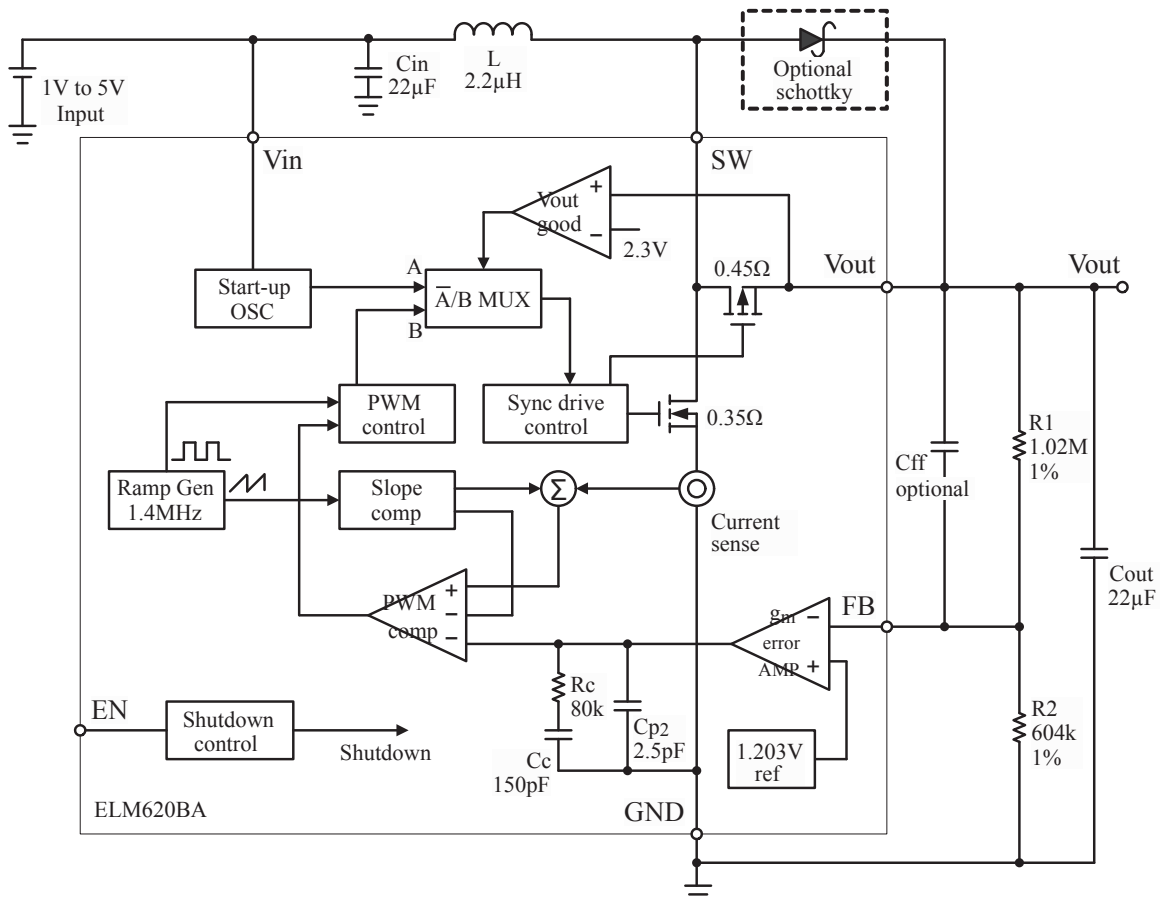

# ELM620BA 1.4MHz

## high efficiency synchronous PWM step up DC/DC converter

<https://www.elm-tech.com>

### ■Electrical characteristics

$V_{in}=1.2V$ ,  $V_{out}=3.3V$ ,  $T_{op}=25^{\circ}C$ , unless otherwise noted

Parameter	Symbol	Condition	Min.	Typ.	Max.	Unit
Output voltage range (adj.)	Vout		2.5		6.0	V
Minimum start-up voltage	Vst	Iload=1mA		0.9	1.1	V
Minimum operating voltage	Vin	EN=Vin		0.60	0.75	V
Switching frequency	Fsw		1.1	1.4	1.7	MHz
Maximum duty cycle	Dmax	Vfb=1.15V	80	87		%
Current limit delay to output	tlimdly			40		ns
Feedback voltage	Vfb		1.165	1.203	1.241	V
Feedback input current	Ifb	Vfb=1.22V		1		nA
NMOS switch leakage	IleakN	Vsw=5V		0.1	5.0	$\mu A$
PMOS switch leakage	IleakP	Vsw=0V		0.1	5.0	$\mu A$
NMOS switch ON resistance	RswN	Vout=3.3V		0.35		$\Omega$
PMOS switch ON resistance	RswP	Vout=3.3V		0.45		$\Omega$
NMOS current limit	IlimN		700	950		mA
Quiescent current (Active)	Iq	Measured on Vout, Non-switching		300	500	$\mu A$
Shutdown current	Is	Ven=0V, Including switch leakage		0.1	1.0	$\mu A$
EN input high	Venh		1			V
EN input low	Venl				0.35	V
EN input current	Ien	Ven=5.5V		0.01	1.00	$\mu A$

### ■Test circuits

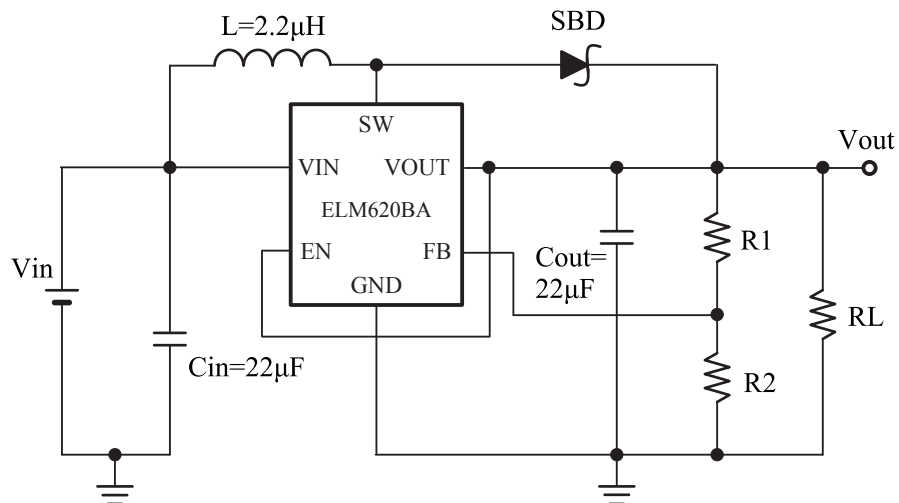

# ELM620BA 1.4MHz high efficiency synchronous PWM step up DC/DC converter

https://www.elm-tech.com

## ■Application notes

### 1) PCB layout guidelines

The high speed operation of ELM620BA demands careful attention to board layout, and in order to get advertised performance, a well-planned layout is required. Figure-1 is an example which shows the recommended component placement with optional Schottky diode. A large ground pin copper area will help to lower the chip temperature. A multilayer board with a separate ground plane is ideal, but not absolutely necessary.

Fig-1

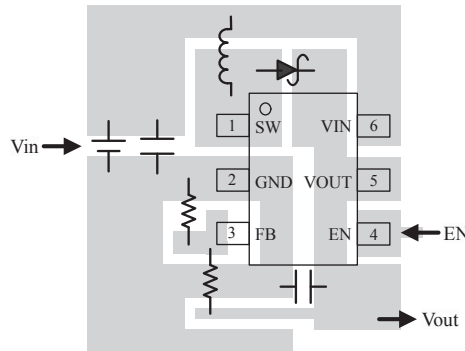

Figure 1: Recommended component placement for single layer board with optional Schottky diode. Traces carrying high current are direct. Trace area at FB pin is small. Lead length to battery is short.

### 2) Inductor selection

ELM620BA can utilize small surface mount and chip inductors due to its fast 1.4MHz switching frequency. Typically, a 2.2μH inductor is recommended for most applications; larger values of inductance will allow greater output current capability by reducing the inductor ripple current. Increasing the inductance above 10μH will increase size while providing little improvement in output current capability.

$$I_{out(max)} = \eta \times \left( I_p - \frac{V_{in} \times D}{2 \times f \times L} \right) \times (1 - D)$$

where:  $\eta$  = estimated efficiency

$I_p$  = peak current limit value (0.7A)

$V_{in}$  = input (battery) voltage

$D$  = steady-state duty ratio =  $(V_{out} - V_{in}) / V_{out}$

$f$  = switching frequency (1.4MHz typical)

$L$  = inductance value

The inductor current ripple is typically set for 20% to 40% of the maximum inductor current ( $I_p$ ). High frequency ferrite core inductor materials reduce frequency dependent power losses compared to cheaper powdered iron types. The inductor should have low ESR (series resistance of the windings) to reduce the  $I^2R$  power losses, and must be able to handle the peak inductor current without saturating. Molded chokes and some chip inductors usually do not have enough core to support the peak inductor currents of 950mA seen on ELM620BA. To minimize radiated noise, ELM recommends using a toroid, pot core or shielded bobbin inductor. See Table for some suggested components and suppliers.

Table : Recommended inductors.

Part	L	Max. DCR	Max. DC current	Size: W × L × H	Vendor
	(μH)	(mΩ)	(A)	(mm <sup>3</sup> )	
CDRH3D16	2.2	75	1.2	3.8×3.8×1.8	Sumida
CDH3B16	2.2	70	1.2	4.0×4.0×1.8	Ceaiya

# ELM620BA 1.4MHz high efficiency synchronous PWM step up DC/DC converter

<https://www.elm-tech.com>

### 3) Output and input capacitor selection

Low ESR (equivalent series resistance) capacitors should be used to minimize the output voltage ripple. Multilayer ceramic capacitors are an excellent choice, as they have extremely low ESR and are available in small footprints. A 4.7 $\mu$ F to 22 $\mu$ F output capacitor is sufficient for most applications; larger values up to 22 $\mu$ F may be used to obtain extremely low output voltage ripple and improve transient response. An additional phase lead capacitor may be required with output capacitors larger than 10 $\mu$ F to maintain acceptable phase margin. X5R and X7R dielectric materials are preferred for their ability to maintain capacitance over wide voltage and temperature ranges.

Low ESR input capacitors reduce input switching noise and reduce the peak current drawn from the battery. It follows that ceramic capacitors are also a good choice for input decoupling and should be located as closely as possible to the device. A 10 $\mu$ F input capacitor is sufficient for virtually any application. Larger values may be used without limitations.

### ■ Marking

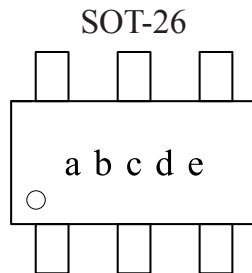

a to e : Assembly lot No. —  
A to Z (I, O, X excepted) and 0 to 9

# ELM620BA 1.4MHz

## high efficiency synchronous PWM step up DC/DC converter

<https://www.elm-tech.com>

### ■ Typical characteristics

- $V_{out}=3.3V$  :  $C_{in}=22\mu F$ ,  $C_{out}=22\mu F$ ,  $L=2.2\mu H$ ,  $R1=46.6k\Omega$ ,  $R2=26.7k\Omega$ ,  $T_{op}=25^{\circ}C$

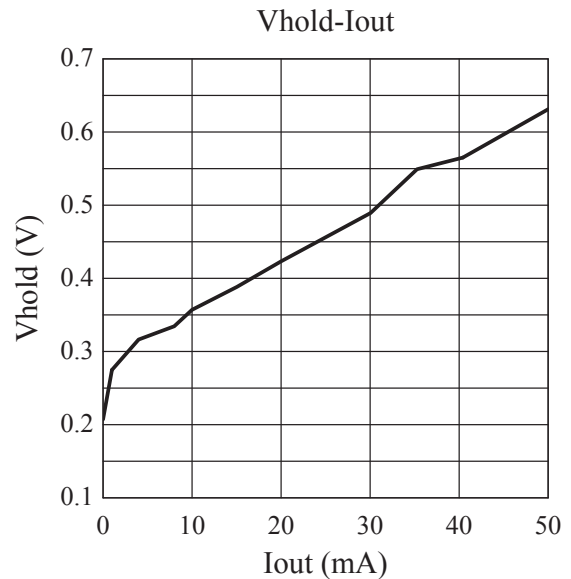
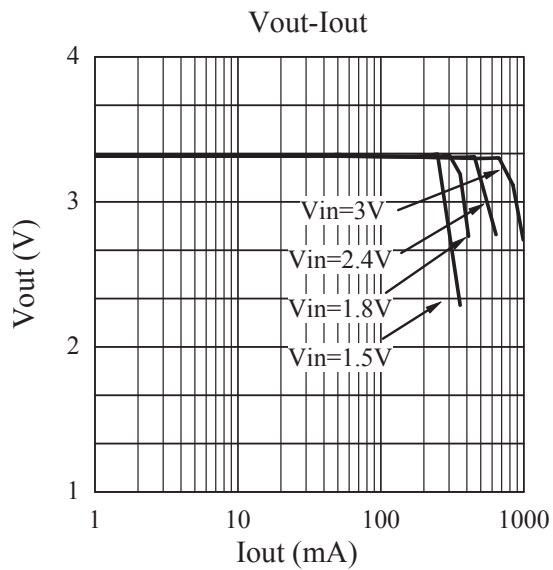
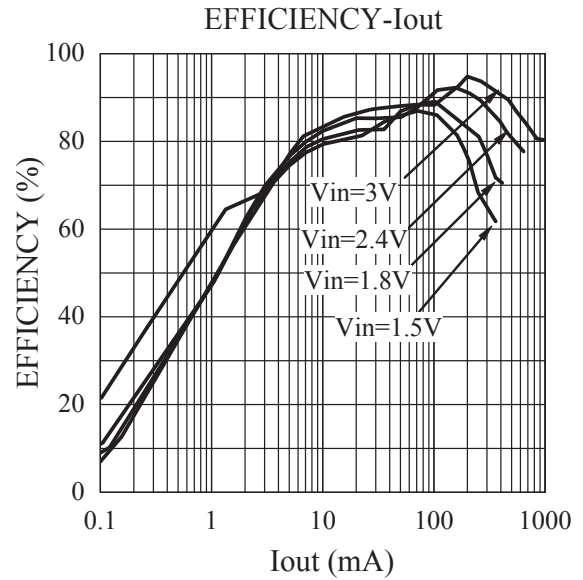
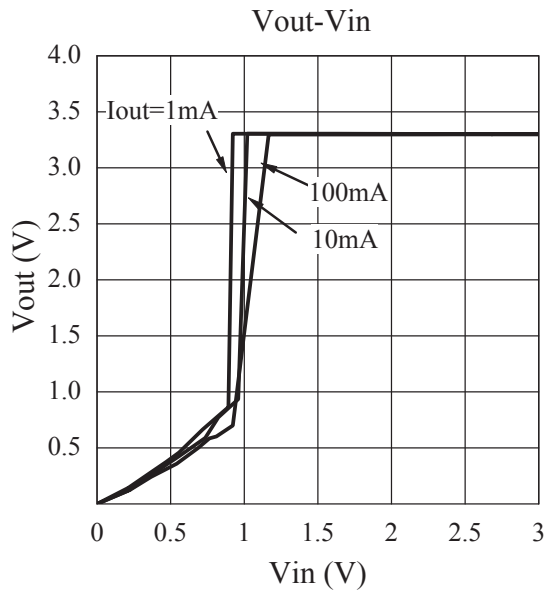

# ELM620BA 1.4MHz high efficiency synchronous PWM step up DC/DC converter

<https://www.elm-tech.com>

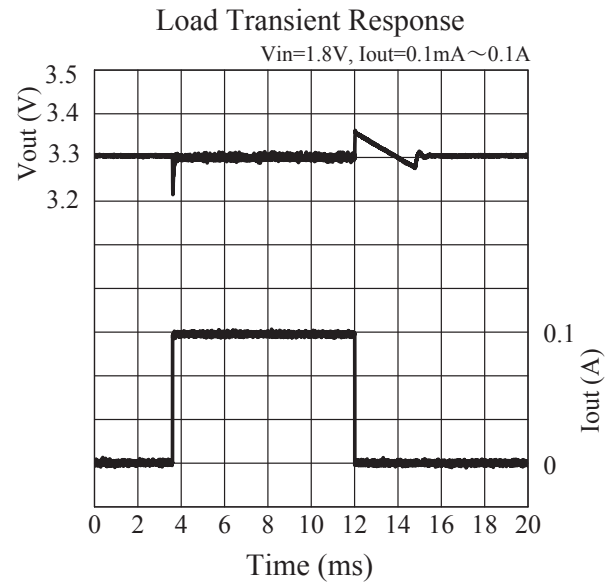
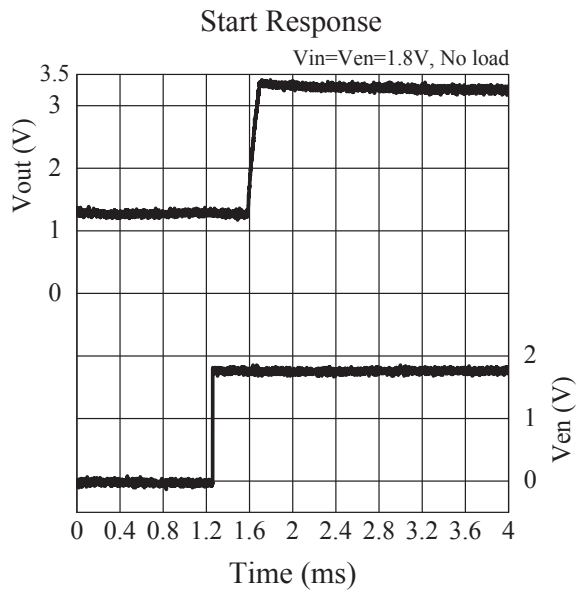
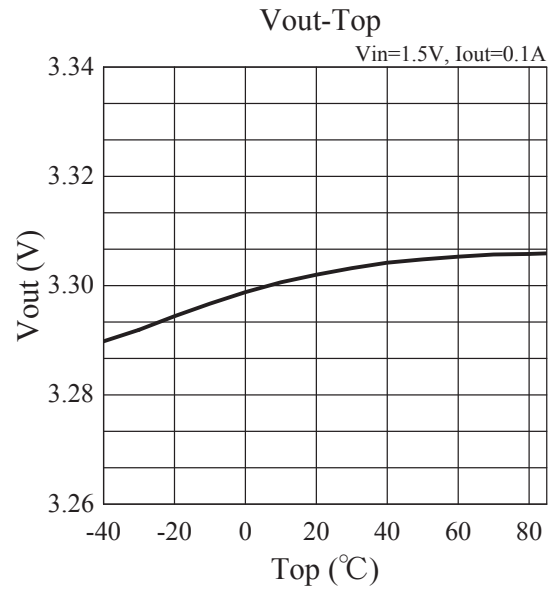
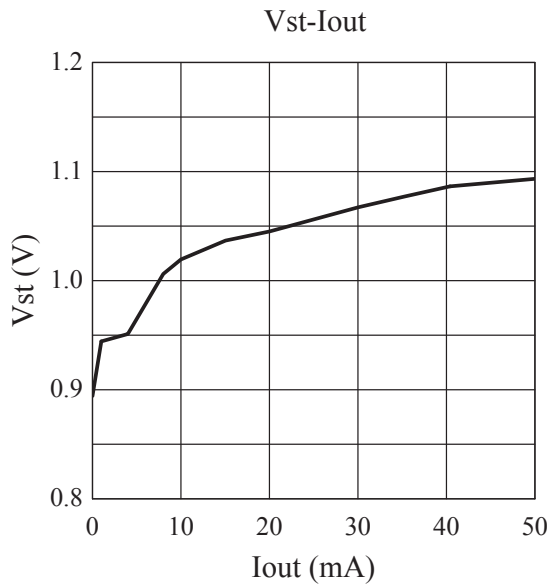



# ELM620BA 1.4MHz

## high efficiency synchronous PWM step up DC/DC converter

<https://www.elm-tech.com>

- $V_{out}=5.0V$  :  $C_{in}=22\mu F$ ,  $C_{out}=22\mu F$ ,  $L=2.2\mu H$ ,  $R1=68.5k\Omega$ ,  $R2=21.7k\Omega$ ,  $T_{op}=25^{\circ}C$

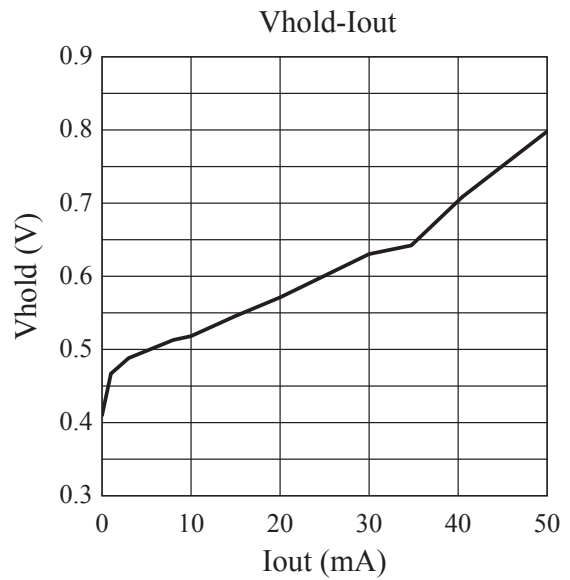
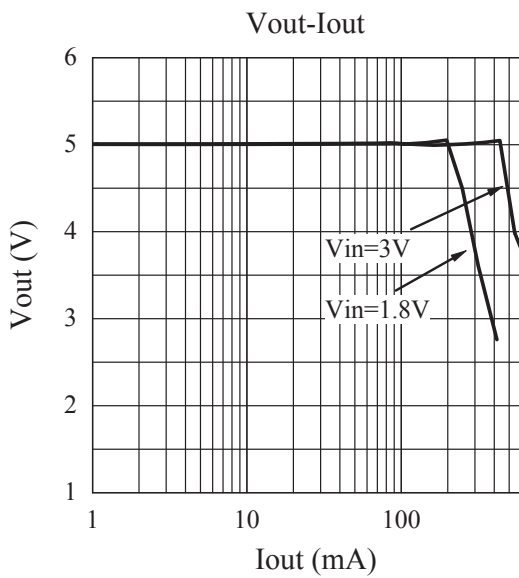
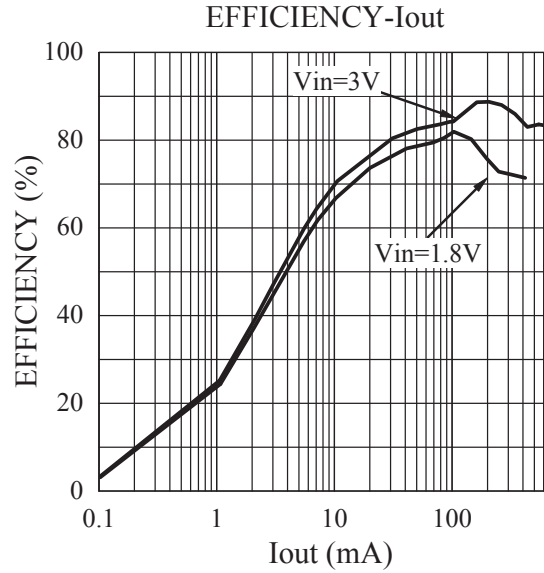
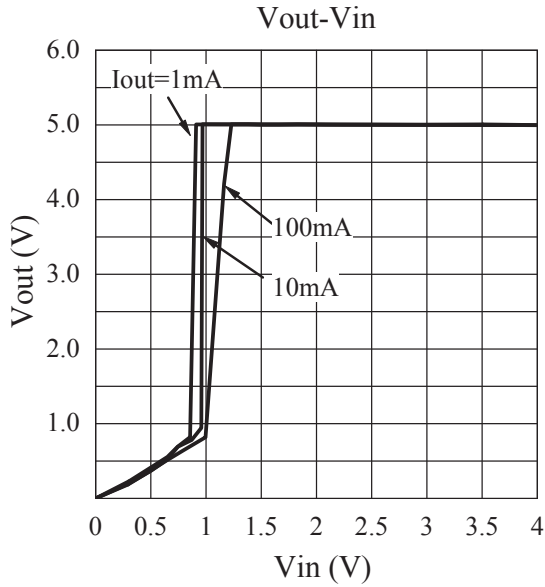

# ELM620BA 1.4MHz high efficiency synchronous PWM step up DC/DC converter

<https://www.elm-tech.com>

