

HIGH SPEED CMOS LOGIC IC ELM7SH08xB 2-input AND gate

<http://www.elm-tech.com>

■General description

ELM7SH08xB is CMOS 2-input AND gate which is suitable for battery-operated devices because of its low voltage and ultra high speed operation. The low power consumption contributes to longer battery life, which allows long time operation of devices. The internal circuit which provides high noise immunity and stable output is composed of 4 stages, including buffered output.

■Features

- Same electrical characteristic and high speed operation as 74VHC series
- Low consumption current : $I_{dd}=1.0\mu A(\text{Max.})(T_{op}=25^{\circ}C)$
- Wide power voltage range : 2.0V to 5.5V
- Wide input voltage range : $V_{ih}=5.5V(\text{Max.})(V_{dd}=0 \text{ to } 5.5V)$
- High speed : $T_{pd}=2ns(\text{Typ.})(V_{dd}=5.0V)$
- Small package : SOT-25, SC-70-5(SOT-353)
- Same function and pin configuration as ELM7SxxB

■Application

- Cell phones
- Digital cameras
- Portable electrical appliances like PDA, etc.
- Computers and peripherals
- Digital electrical appliances like LCD TV sets, DVD recorders/players, STB, etc.
- Modification inside print board, adjustment of timing, solution to noise
- Power voltage change from 5V to 3V

■Selection guide

ELM7SH08xBEL

Symbol	Function	
a	Function	08: 2-input AND gate
b	Package	M: SOT-25 T : SC-70-5(SOT-353)
c	Product version	B
d	Taping direction	EL: Refer to PKG file

ELM7SH 08 x B EL
 $\begin{matrix} \uparrow & \uparrow & \uparrow & \uparrow \\ a & b & c & d \end{matrix}$

■Maximum absolute ratings

Parameter	Symbol	Limit	Unit
Power supply voltage	Vdd	-0.5 to +6.0	V
Input voltage	Vin	-0.5 to +6.0	V
Output voltage	Vout	-0.5 to Vdd+0.5	V
Input protection diode current	Iik	-20	mA
Output parasitic diode current	Iok	±20	mA
Output current	Iout	±25	mA
VDD/GND current	Idd, Ignd	±50	mA
Power dissipation	Pd	150	mW
Storage temperature	Tstg	-65 to +150	°C

HIGH SPEED CMOS LOGIC IC ELM7SH08xB 2-input AND gate

<http://www.elm-tech.com>

■Suggested operating condition

Parameter	Symbol	Limit		Unit
Power voltage	Vdd	2.0 to 5.5		V
Input voltage	Vin	0 to 5.5		V
Output voltage	Vout	0 to Vdd		V
Operating temperature	Top	-40 to +85		°C
High-input down-time	tr, tf	Vdd=3.3±0.3V	0 to 200	ns
		Vdd=5.0±0.5V	0 to 100	

■Pin configuration

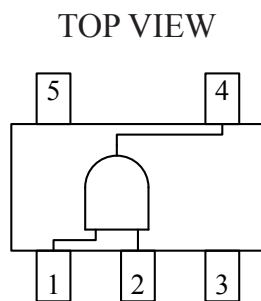

Pin No.	Pin name
1	INB
2	INA
3	GND
4	OUTX
5	VDD

Input		Output
INA	INB	OUTX
Low	Low	Low
Low	High	Low
High	Low	Low
High	High	High

■DC electrical characteristics

Parameter	Sym.	Vdd	Top=25°C			Top=-40 to +85°C		Unit	Condition	
			Min.	Typ.	Max.	Min.	Max.			
Input voltage	Vih	2.0	1.50			1.50		V		
		3.0	2.10			2.10				
		5.5	3.85			3.85				
	Vil	2.0			0.50		0.50	V		
		3.0			0.90		0.90			
		5.5			1.65		1.65			
Output voltage	Voh	2.0	1.90	2.00		1.90		V	Vin=Vih	Ioh=-50µA
		3.0	2.90	3.00		2.90				
		4.5	4.40	4.50		4.40				
		3.0	2.58			2.48				
		4.5	3.94			3.80				
	Vol	2.0			0.10		0.10	V	Vin=Vil or Vih	Iol=50µA
		3.0			0.10		0.10			
		4.5			0.10		0.10			
		3.0			0.36		0.44			
		4.5			0.36		0.44			
	Input current	Iin	5.5	-0.1		0.1	-1.0	1.0	µA	Vin=Vdd or GND
	Static current	Idd	5.5			1.0		10.0	µA	Vin=Vdd or GND

HIGH SPEED CMOS LOGIC IC ELM7SH08xB 2-input AND gate

<http://www.elm-tech.com>

■ AC electrical characteristics

$t_r=t_f=3\text{ns}$

Parameter	Sym.	Vdd	CL	Top=25°C			Top=-40 to +85°C		Unit	Condition
				Min.	Typ.	Max.	Min.	Max.		
Propagation delay-time	tPLH	3.3±0.3	15		3.7	8.8	1.0	10.5	ns	Refer to test circuit
	tPHL				3.2	8.8	1.0	10.5		
	tPLH	3.3±0.3	50		5.2	12.3	1.0	14.0		
	tPHL				4.5	12.3	1.0	14.0		
	tPLH	5.0±0.5	15		2.8	5.9	1.0	7.0		
	tPHL				2.4	5.9	1.0	7.0		
	tPLH	5.0±0.5	50		3.7	7.9	1.0	9.0		
	tPHL				3.4	7.9	1.0	9.0		
Input capacity	Cin	5.0			4.0	10.0		10.0	pF	Vin=Vdd or GND
Equivalent inner capacity	Cpd				9.3				pF	f=1MHz

* Cpd is IC's inner equivalent capacity which is calculated from non-loaded operating current consumption referred to test circuit. Averaged operating current consumption at non load is calculated as following formula: $I_{dd(opr)} = Cpd \cdot Vdd \cdot f_{in} + I_{dd}$

■ Test circuit

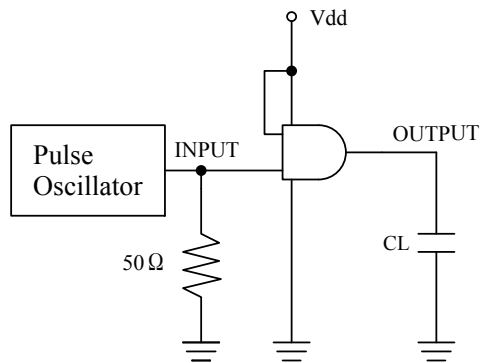

■ Measured wave pattern

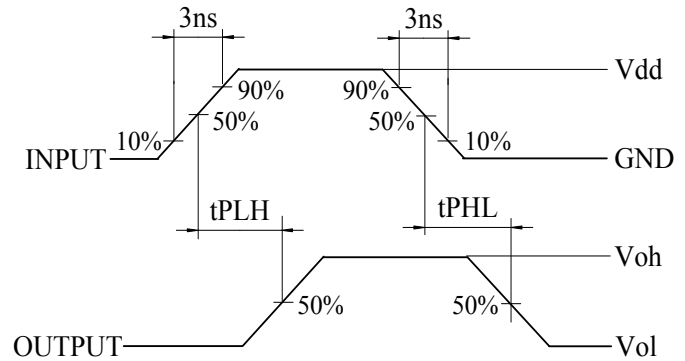

* Output should be opened when measuring current consumption.

■ Marking

SC-70-5

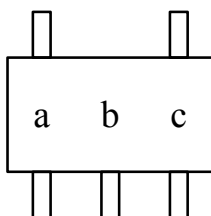

SOT-25

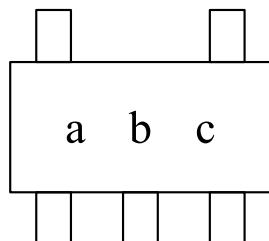

Sym.	Mark	Content
a	F	ELM7SH series
b	2	ELM7SH08xB
c	A to Z (except I, O, X)	Lot No.