

# HIGH SPEED CMOS LOGIC IC ELM7SH32xB 2-input OR gate

<http://www.elm-tech.com>

## ■General description

ELM7SH32xB is CMOS 2-input OR gate which is suitable for battery-operated devices because of its low voltage and ultra high speed operation. The low power consumption contributes to longer battery life, which allows long time operation of devices. The internal circuit which provides high noise immunity and stable output is composed of 3 stages, including buffered output. All input pins have an input tolerant circuit configuration. In other words, there is no diode on the positive side (forward from input to Vdd), so it ensures that 0 to 5.5 V can be applied to the input pins without regard to the supply voltage.

## ■Features

- Same electrical characteristic and high speed operation as 74VHC series
- Low consumption current : I<sub>dd</sub>=1.0μA(Max.)(T<sub>op</sub>=25°C)
- Wide power voltage range : 1.65V to 5.5V
- Wide input voltage range : V<sub>ih</sub>=5.5V(Max.)(V<sub>dd</sub>=0 to 5.5V)
- High speed : T<sub>pd</sub>=3.8ns(Typ.)(V<sub>dd</sub>=5.0V)
- Small package : SOT-25, SC-70-5(SOT-353)
- Same function and pin configuration as ELM7SxxB

## ■Application

- Cell phones
- Digital cameras
- Portable electrical appliances like PDA, etc.
- Computers and peripherals
- Digital electrical appliances like LCD TV sets, DVD recorders/players, STB, etc.
- Modification inside print board, adjustment of timing, solution to noise
- Power voltage change from 5V to 3V (Input tolerant)

## ■Selection guide

ELM7SH32xBEL

Symbol		
a	Function	32: 2-input OR gate
b	Package	M: SOT-25 T: SC-70-5(SOT-353)
c	Product version	B
d	Taping direction	EL: Refer to PKG file

ELM7SH 3 2 x B EL  
 ↑ ↑ ↑ ↑  
 a b c d

## ■Maximum absolute ratings

Parameter	Symbol	Limit	Unit
Power supply voltage	V <sub>dd</sub>	-0.5 to +6.0	V
Input voltage	V <sub>in</sub>	-0.5 to +6.0	V
Output voltage	V <sub>out</sub>	-0.5 to V <sub>dd</sub> +0.5	V
Input protection diode current	I <sub>ik</sub>	-20	mA
Output parasitic diode current	I <sub>ok</sub>	±20	mA
Output current	I <sub>out</sub>	±25	mA
VDD/GND current	I <sub>dd</sub> , I <sub>gnd</sub>	±50	mA
Power dissipation	P <sub>d</sub>	150	mW
Storage temperature	T <sub>stg</sub>	-65 to +150	°C

# HIGH SPEED CMOS LOGIC IC ELM7SH32xB 2-input OR gate

<http://www.elm-tech.com>

## ■Suggested operating condition

Parameter	Symbol	Limit		Unit
Power voltage	Vdd	1.65 to 5.5		V
Input voltage	Vin	0 to 5.5		V
Output voltage	Vout	0 to Vdd		V
Operating temperature	Top	-40 to +85		°C
High-input down-time	tr, tf	Vdd=1.8±0.15V	0 to 300	ns
		Vdd=2.5±0.2V	0 to 200	
		Vdd=3.3±0.3V	0 to 200	
		Vdd=5.0±0.5V	0 to 100	

## ■Pin configuration

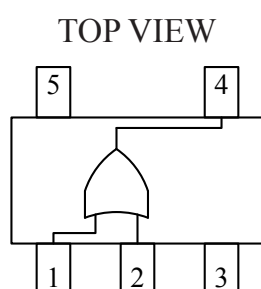

Pin No.	Pin name
1	INB
2	INA
3	GND
4	OUTX
5	VDD

Input		Output
INA	INB	OUTX
Low	Low	Low
Low	High	High
High	Low	High
High	High	High

## ■DC electrical characteristics

Parameter	Sym.	Vdd	Top=25°C		Top=-40 to +85°C		Unit	Condition	
			Min.	Max.	Min.	Max.			
Input voltage	Vih	1.65	1.23	-	1.23	-	V		
		2.0	1.50	-	1.50	-			
		3.0	2.10	-	2.10	-			
		5.5	3.85	-	3.85	-			
	Vil	1.65	-	0.42	-	0.42	V		
		2.0	-	0.50	-	0.50			
		3.0	-	0.90	-	0.90			
		5.5	-	1.65	-	1.65			
Output voltage	Voh	1.65	1.55	-	1.55	-	V	Vin=Vil or Vih	Ioh=-50μA
		2.0	1.90	-	1.90	-			Ioh=-4mA
		3.0	2.90	-	2.90	-			Ioh=-8mA
		4.5	4.40	-	4.40	-			
		3.0	2.58	-	2.48	-			
		4.5	3.94	-	3.80	-			
	Vol	1.65	-	0.10	-	0.10	V	Vin=Vil	Iol=50μA
		2.0	-	0.10	-	0.10			
		3.0	-	0.10	-	0.10			
		4.5	-	0.10	-	0.10			Iol=4mA Iol=8mA
		3.0	-	0.36	-	0.44			
		4.5	-	0.36	-	0.44			
Input current	Iin	5.5	-0.1	0.1	-1.0	1.0	μA	Vin=Vdd or GND	
Static current	Idd	5.5	-	1.0	-	10.0	μA	Vin=Vdd or GND	

# HIGH SPEED CMOS LOGIC IC ELM7SH32xB 2-input OR gate

<http://www.elm-tech.com>

## AC electrical characteristics

$t_r=t_f=3\text{ns}$

Parameter	Sym.	Vdd	CL	Top=25°C			Top=-40 to +85°C		Unit	Condition
				Min.	Typ.	Max.	Min.	Max.		
Propagation delay-time	tPLH	1.8±0.15	15	-	12.3	22.5	1.0	25.0	ns	Refer to test circuit
	tPHL			-	12.3	22.5	1.0	25.0		
	tPLH	1.8±0.15	50	-	17.7	31.0	1.0	34.0		
	tPHL			-	17.7	31.0	1.0	34.0		
	tPLH	2.5±0.2	15	-	7.1	12.8	1.0	15.0		
	tPHL			-	7.1	12.8	1.0	15.0		
	tPLH	2.5±0.2	50	-	9.6	16.2	1.0	19.0		
	tPHL			-	9.6	16.2	1.0	19.0		
	tPLH	3.3±0.3	15	-	5.5	7.9	1.0	9.5		
	tPHL			-	5.5	7.9	1.0	9.5		
	tPLH	3.3±0.3	50	-	8.0	11.4	1.0	13.0		
	tPHL			-	8.0	11.4	1.0	13.0		
	tPLH	5.0±0.5	15	-	3.8	5.5	1.0	6.5		
	tPHL			-	3.8	5.5	1.0	6.5		
	tPLH	5.0±0.5	50	-	5.3	7.5	1.0	8.5		
	tPHL			-	5.3	7.5	1.0	8.5		
Input capacity	Cin	5.0	-	-	2.0	10.0	-	10.0	pF	Vin=Vdd or GND
Equivalent inner capacity	Cpd	-	-	-	8.9	-	-	-	pF	f=1MHz

\* Cpd is IC's inner equivalent capacity which is calculated from non-loaded operating current consumption referred to test circuit. Averaged operating current consumption at non load is calculated as following formula:  $I_{dd(opr)}=Cpd \cdot Vdd \cdot f_{in}+I_{dd}$

## Test circuit

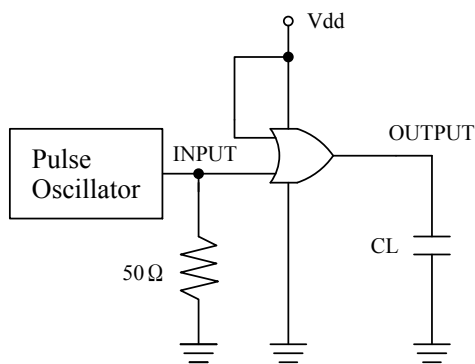

\* Output should be opened when measuring current consumption.

## Measured wave pattern

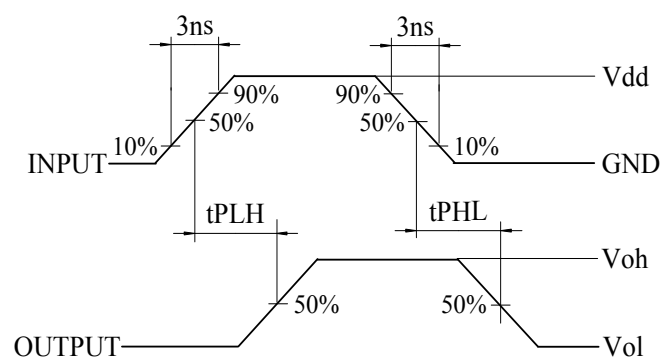

## Marking

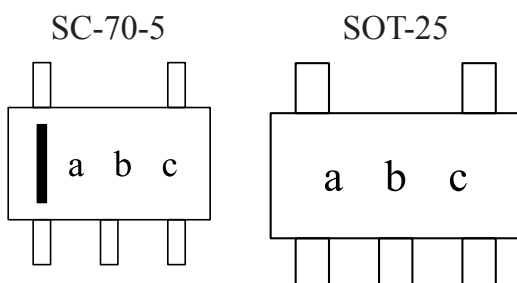

Sym.	Mark	Content
a	F	ELM7SH series
b	4	ELM7SH32xB
c	A to Z (except I, O, X)	Lot No.