

CMOS LOGIC IC ELM7S32B 2-input OR gate

<http://www.elm-tech.com>

■General description

ELM7S32B is CMOS 2-input OR gate IC. It realizes high speed operation similar to LS-TTL with lower power consumption by CMOS features. The inner circuit structure of 3-stage logic gate obtains wider noise immunity and constant output.

■Features

- Same electrical characteristic as 74HC series (output current is around 1/2 of 74HC series)
- Low consumption current : $I_{dd}=1.0\mu\text{A}(\text{Max.})(T_{op}=25^{\circ}\text{C})$
- Wide power voltage range : 2.0V to 6.0V
- High speed : $T_{pd}=5\text{ns}(\text{Typ.})(V_{dd}=5.0\text{V})$
- Symmetrical output impedance : $|I_{oh}|=|I_{ol}|=2\text{mA}(\text{Min.})(V_{dd}=4.5\text{V})$
- Small package : SOT-25

■Application

- Cell phones
- Digital cameras
- Portable electrical appliances like PDA, etc.
- Computers and peripherals
- Digital electrical appliances like LCD TV sets, DVD recorders/players, STB, etc.
- Modification inside print board, adjustment of timing, solution to noise

■Selection guide

ELM7S32BEL

Symbol	Function	
a	Function	32: 2-input OR gate
b	Product version	B
c	Taping direction	EL: Refer to PKG file

ELM7S 3 2 B EL
 ↑ ↑ ↑
 a b c

■Maximum absolute ratings

Parameter	Symbol	Limit	Unit
Power supply voltage	V _{dd}	-0.5 to +7.0	V
Input voltage	V _{in}	-0.5 to V _{dd} +0.5	V
Output voltage	V _{out}	-0.5 to V _{dd} +0.5	V
Input protection diode current	I _{ik}	±20	mA
Output parasitic diode current	I _{ok}	±20	mA
Output current	I _{out}	±25	mA
VDD/GND current	I _{dd} , I _{gnd}	±25	mA
Power dissipation	P _d	200	mW
Storage temperature	T _{stg}	-65 to +150	°C

CMOS LOGIC IC ELM7S32B 2-input OR gate

<http://www.elm-tech.com>

■Suggested operating condition

Parameter	Symbol	Limit		Unit
Power voltage	Vdd	2.0 to 6.0		V
Input voltage	Vin	0 to Vdd		V
Output voltage	Vout	0 to Vdd		V
Operating temperature	Top	-40 to +85		°C
High-input down-time	tr, tf	Vdd=2.0V	0 to 1000	ns
		Vdd=4.5V	0 to 500	
		Vdd=6.0V	0 to 400	

■Pin configuration

SOT-25(TOP VIEW)

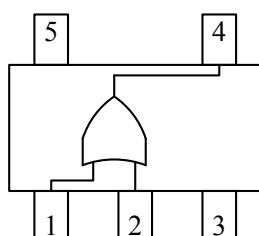

Pin No.	Pin name
1	INB
2	INA
3	GND
4	OUTX
5	VDD

Input		Output
INA	INB	OUTX
Low	Low	Low
Low	High	High
High	Low	High
High	High	High

■AC electrical characteristics

CL=15pF, tr=tf=6ns, Vdd=5V

Parameter	Sym.	Top=25°C			Unit	Condition
		Min.	Typ.	Max.		
Output transition time	tTLH		4	10	ns	Refer to test circuit
	tTHL		4	10		
Propagation delay-time	tPLH		5	15	ns	Refer to test circuit
	tPHL		5	15		

CL=50pF, tr=tf=6ns

Parameter	Sym.	Vdd	Top=25°C			Top=-40 to +85°C		Unit	Condition
			Min.	Typ.	Max.	Min.	Max.		
Output transition time	tTLH	2.0		22	125		155	ns	Refer to test circuit
		4.5		7	25		31		
		6.0		6	21		26		
	tTHL	2.0		18	125		155	ns	
		4.5		6	25		31		
		6.0		6	21		26		
Propagation delay-time	tPLH	2.0		17	100		125	ns	Refer to test circuit
		4.5		7	20		25		
		6.0		6	17		21		
	tPHL	2.0		18	100		125	ns	
		4.5		8	20		25		
		6.0		7	17		21		
Input capacity	Cin			5	10		10	pF	
Equivalent inner capacity	Cpd			10				pF	

* Cpd is IC's inner equivalent capacity which is calculated from non-loaded operating current consumption referred to test circuit. Averaged operating current consumption at non load is calculated as following formula: $I_{dd(opr)} = Cpd \cdot Vdd \cdot f_{in} + I_{dd}$

CMOS LOGIC IC ELM7S32B 2-input OR gate

<http://www.elm-tech.com>

DC electrical characteristics

Parameter	Sym.	Vdd	Top=25°C			Top=-40 to +85°C		Unit	Condition		
			Min.	Typ.	Max.	Min.	Max.				
Input voltage	Vih	2.0	1.50			1.50		V			
		4.5	3.15			3.15					
		6.0	4.20			4.20					
	Vil	2.0			0.50		0.50	V			
		4.5			1.35		1.35				
		6.0			1.80		1.80				
Output voltage	Voh	2.0	1.90	2.00		1.90	V	Vin=Vih or Vil	Ioh=-20μA		
		4.5	4.40	4.50		4.40					
		6.0	5.90	6.00		5.90					
		4.5	4.18	4.36		4.13				Ioh=-2mA	
		6.0	5.68	5.83		5.63				Ioh=-2.6mA	
		6.0	5.68	5.83		5.63				Ioh=-2.6mA	
	Vol	2.0		0.00	0.10		0.10	V	Vin=Vil	Iol=20μA	
		4.5		0.00	0.10		0.10				
		6.0		0.00	0.10		0.10				
		4.5		0.12	0.26		0.33				Iol=2mA
		6.0		0.16	0.26		0.33				Iol=2.6mA
		6.0		0.16	0.26		0.33				Iol=2.6mA
Input current	Iin	6.0	-0.1		0.1	-1.0	1.0	μA	Vin=Vdd or GND		
Static current	Idd	6.0			1.0		10.0	μA	Vin=Vdd or GND		

Test circuit

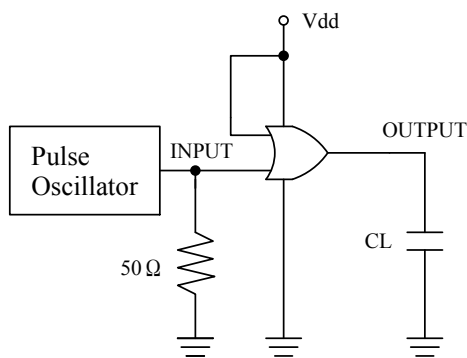

Measured wave pattern

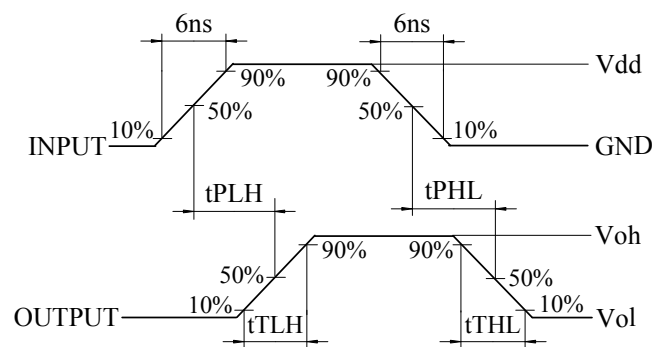

* Output should be opened when measuring current consumption.

Marking

SOT-25

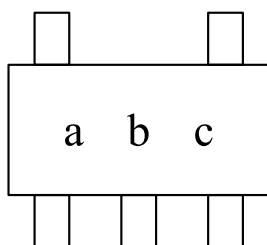

Sym.	Mark	Content
a	E	ELM7S series
b	4	ELM7S32B
c	A to Z (except I, O, X)	Lot No.