

CMOS LOGIC IC ELM7S86B 2-input Exclusive OR gate

<https://www.elm-tech.com>

■General description

ELM7S86B is CMOS 2-input EXOR gate IC. It realizes high speed operation similar to LS-TTL with lower power consumption by CMOS features. The inner circuit structure of 3-stage logic gate obtains wider noise immunity and constant output.

■Features

- Same electrical characteristic as 74HC series (output current is around 1/2 of 74HC series)
- Low consumption current : $I_{dd}=1.0\mu\text{A}(\text{Max.})(T_{op}=25^{\circ}\text{C})$
- Wide power voltage range : 2.0V to 6.0V
- High speed : $T_{pd}=5\text{ns}(\text{Typ.})(V_{dd}=5.0\text{V})$
- Symmetrical output impedance : $|I_{oh}|=|I_{ol}|=2\text{mA}(\text{Min.})(V_{dd}=4.5\text{V})$
- Small package : SOT-25

■Application

- Cell phones
- Digital cameras
- Portable electrical appliances like PDA, etc.
- Computers and peripherals
- Digital electrical appliances like LCD TV sets, DVD recorders/players, STB, etc.
- Modification inside print board, adjustment of timing, solution to noise

■Selection guide

ELM7S86BEL

Symbol		
a	Function	86: 2-input Exclusive OR gate
b	Product version	B
c	Taping direction	EL: Refer to PKG file

ELM7S 86 B EL
↑ ↑ ↑
a b c

■Maximum absolute ratings

Parameter	Symbol	Limit	Unit
Power supply voltage	V _{dd}	-0.5 to +7.0	V
Input voltage	V _{in}	-0.5 to V _{dd} +0.5	V
Output voltage	V _{out}	-0.5 to V _{dd} +0.5	V
Input protection diode current	I _{ik}	±20	mA
Output parasitic diode current	I _{ok}	±20	mA
Output current	I _{out}	±25	mA
VDD/GND current	I _{dd} , I _{gnd}	±25	mA
Power dissipation	P _d	200	mW
Storage temperature	T _{stg}	-65 to +150	°C

CMOS LOGIC IC ELM7S86B 2-input Exclusive OR gate

<https://www.elm-tech.com>

■Suggested operating condition

Parameter	Symbol	Limit		Unit
Power voltage	Vdd	2.0 to 6.0		V
Input voltage	Vin	0 to Vdd		V
Output voltage	Vout	0 to Vdd		V
Operating temperature	Top	-40 to +85		°C
High-input down-time	tr, tf	Vdd=2.0V	0 to 1000	ns
		Vdd=4.5V	0 to 500	
		Vdd=6.0V	0 to 400	

■Pin configuration

SOT-25(TOP VIEW)

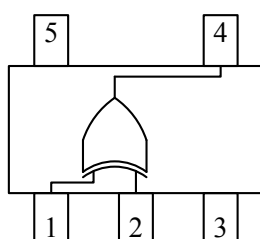

Pin No.	Pin name
1	INB
2	INA
3	GND
4	OUTX
5	VDD

Input		Output
INA	INB	OUTX
Low	Low	Low
Low	High	High
High	Low	High
High	High	Low

■AC electrical characteristics

CL=15pF, tr=tf=6ns, Vdd=5V

Parameter	Sym.	Top=25°C			Unit	Condition
		Min.	Typ.	Max.		
Output transition time	tTLH		7	10	ns	Refer to test circuit
	tTHL		7	10		
Propagation delay-time	tPLH		9	20	ns	Refer to test circuit
	tPHL		9	20		

CL=50pF, tr=tf=6ns

Parameter	Sym.	Vdd	Top=25°C			Top=-40 to +85°C		Unit	Condition
			Min.	Typ.	Max.	Min.	Max.		
Output transition time	tTLH	2.0		50	125		155	ns	Refer to test circuit
		4.5		14	25		31		
		6.0		12	21		26		
	tTHL	2.0		50	125		155	ns	
		4.5		14	25		31		
		6.0		12	21		26		
Propagation delay-time	tPLH	2.0		60	135		170	ns	Refer to test circuit
		4.5		16	27		34		
		6.0		10	22		28		
	tPHL	2.0		60	135		170	ns	
		4.5		16	27		34		
		6.0		10	22		28		
Input capacity	Cin			5	10		10	pF	
Equivalent inner capacity	Cpd			10				pF	

* Cpd is IC's inner equivalent capacity which is calculated from non-loaded operating current consumption referred to test circuit. Averaged operating current consumption at non load is calculated as following formula: $I_{dd}(opr) = Cpd \cdot Vdd \cdot f_{in} + I_{dd}$

CMOS LOGIC IC ELM7S86B 2-input Exclusive OR gate

<https://www.elm-tech.com>

DC electrical characteristics

Parameter	Sym.	Vdd	Top=25°C			Top=-40 to +85°C		Unit	Condition	
			Min.	Typ.	Max.	Min.	Max.			
Input voltage	Vih	2.0	1.50			1.50		V		
		4.5	3.15			3.15				
		6.0	4.20			4.20				
	Vil	2.0			0.50		0.50	V		
		4.5			1.35		1.35			
		6.0			1.80		1.80			
Output voltage	Voh	2.0	1.90	2.00		1.90		V	Vin=Vih or Vil	Ioh=-20μA
		4.5	4.40	4.50		4.40				Ioh=-2mA
		6.0	5.90	6.00		5.90				Ioh=-2.6mA
		4.5	4.18	4.31		4.13				
		6.0	5.68	5.80		5.63				
		6.0	5.68	5.80		5.63				
	Vol	2.0		0.00	0.10		0.10	V	Vin=Vih	Iol=20μA
		4.5		0.00	0.10		0.10			Iol=2mA
		6.0		0.00	0.10		0.10			Iol=2.6mA
		4.5		0.17	0.26		0.33			
		6.0		0.18	0.26		0.33			
		6.0		0.18	0.26		0.33			
Input current	Iin	6.0	-0.1		0.1	-1.0	1.0	μA	Vin=Vdd or GND	
Static current	Idd	6.0			1.0		10.0	μA	Vin=Vdd or GND	

Test circuit

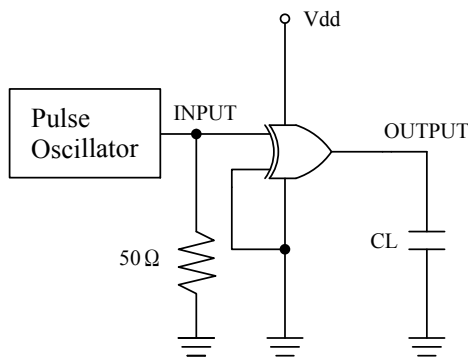

Measured wave pattern

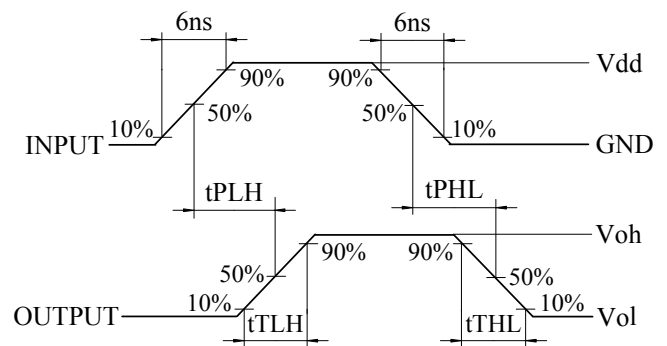

* Output should be opened when measuring current consumption.

Marking

SOT-25

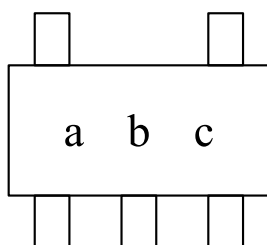

Sym.	Mark	Content
a	E	ELM7S series
b	8	ELM7S86B
c	A to Z (except I, O, X)	Lot No.