

Single N-channel MOSFET

ELM4N20N15AFDA-N

<https://www.elm-tech.com>

■ General description

ELM4N20N15AFDA-N uses advanced trench technology to provide excellent $R_{ds(on)}$, low gate charge and low gate threshold voltage.

■ Features

- $V_{ds}=150V$
- $I_d=23A$
- $R_{ds(on)} = 56m\Omega$ ($V_{gs}=10V$)

■ Maximum absolute ratings

Parameter	Symbol	Limit	Unit	Note	
Drain-source voltage	V_{ds}	150	V		
Gate-source voltage	V_{gs}	± 20	V		
Continuous drain current	I_d	$T_c=25^\circ C$	23.0	A	1
		$T_c=100^\circ C$	16.0		
		$T_a=25^\circ C$	4.5		
		$T_a=70^\circ C$	3.8		
Pulsed drain current	I_{dm}	60	A	2	
Total power dissipation	P_d	$T_c=25^\circ C$	72.6	W	3
		$T_a=25^\circ C$	2.7	W	
Storage temperature range	T_{stg}	-55 to 175	$^\circ C$		
Operating junction temperature range	T_j	-55 to 175	$^\circ C$		

■ Thermal characteristics

Parameter	Symbol	Typ.	Max.	Unit	Note
Thermal resistance junction-ambient	$R_{\theta ja}$	--	55	$^\circ C/W$	1
Thermal resistance junction-case	$R_{\theta jc}$	--	2	$^\circ C/W$	1

■ Pin configuration

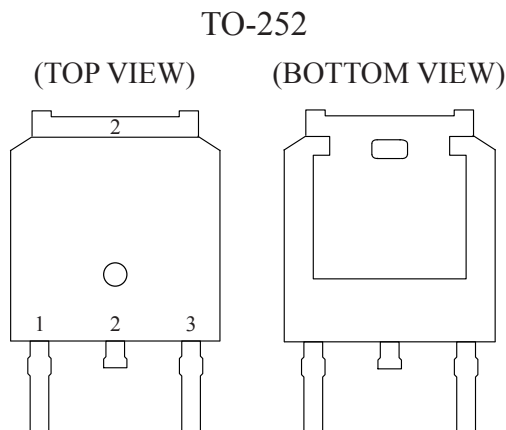

Pin No.	Pin name
1	GATE
2	DRAIN
3	SOURCE

■ Circuit

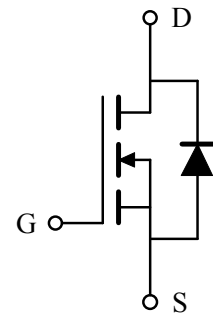

Single N-channel MOSFET

ELM4N20N15AFDA-N

<https://www.elm-tech.com>

■ Electrical characteristics

T_j=25°C. Unless otherwise noted.

Parameter	Symbol	Condition	Min.	Typ.	Max.	Unit	Note
STATIC PARAMETERS							
Drain-source breakdown voltage	BV _{dss}	V _{gs} =0V, I _d =250μA	150	--	--	V	
Static drain-source on-resistance	R _{ds(on)}	V _{gs} =10V, I _d =10A	--	47	56	mΩ	2
Gate threshold voltage	V _{gs(th)}	V _{gs} =V _{ds} , I _d =250μA	2	--	4	V	
Drain-source leakage current	I _{dss}	V _{ds} =120V, V _{gs} =0V	--	--	1	μA	
		V _{ds} =120V, V _{gs} =0V, T _j =55°C	--	--	5		
Gate-source leakage current	I _{gss}	V _{gs} =±20V, V _{ds} =0V	--	--	±100	nA	
Forward transconductance	G _{fs}	V _{ds} =5V, I _d =10A	--	25	--	S	
Continuous source current	I _s	V _{gs} =V _{ds} =0V, Force current	--	--	20	A	1, 4
Diode forward voltage	V _{sd}	V _{gs} =0V, I _s =1A	--	--	1.2	V	2
DYNAMIC PARAMETERS							
Input capacitance	C _{iss}	V _{ds} =75V, V _{gs} =0V, f=1MHz	--	1190	--	pF	
Output capacitance	C _{oss}		--	73	--	pF	
Reverse transfer capacitance	C _{rss}		--	4	--	pF	
SWITCHING PARAMETERS							
Total gate charge	Q _g	V _{ds} =75V, V _{gs} =10V, I _d =10A	--	23.0	--	nC	
Gate-source charge	Q _{gs}		--	5.8	--	nC	
Gate-drain charge	Q _{gd}		--	4.2	--	nC	
Turn-on delay time	t _{d(on)}	V _{dd} =75V, V _{gs} =10V R _{gen} =3.3Ω, I _d =10A	--	16.2	--	ns	
Turn-on rise time	t _r		--	18.6	--	ns	
Turn-off delay time	t _{d(off)}		--	28.5	--	ns	
Turn-off fall time	t _f		--	6.5	--	ns	
Reverse recovery time	t _{rr}	I _f =10A, di/dt=100A/μs	--	45	--	nS	
Reverse recovery charge	Q _{rr}		--	138	--	nC	

NOTE :

1. The data tested by surface mounted on a 1 inch² FR-4 board with 2OZ copper.
2. The data tested by pulsed, pulse width ≤ 300μs and duty cycle ≤ 2%.
3. The power dissipation is limited by 150°C junction temperature.
4. The data is theoretically the same as I_d and I_{dm}, in real applications, should be limited by total power dissipation.

Single N-channel MOSFET

ELM4N20N15AFDA-N

<https://www.elm-tech.com>

■ Typical characteristics

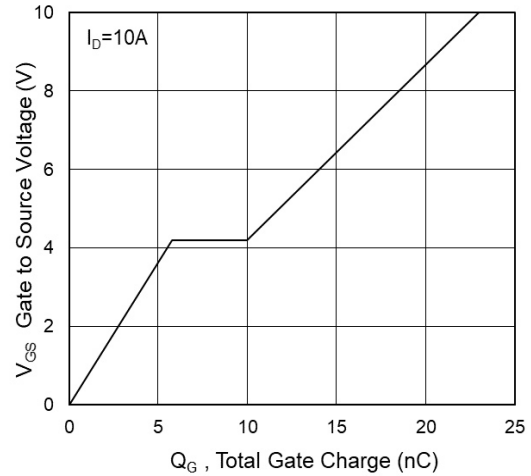
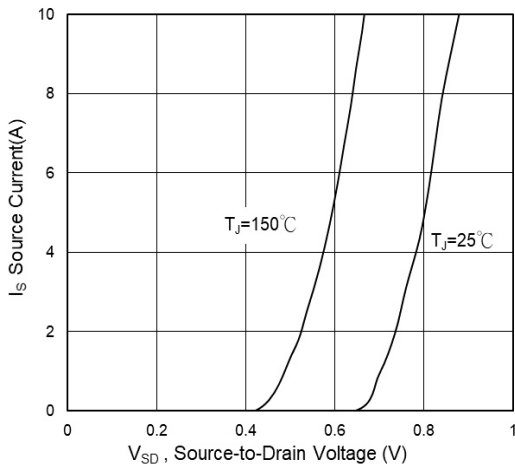
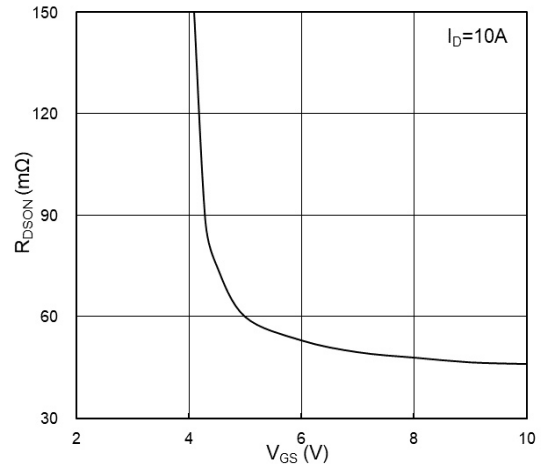
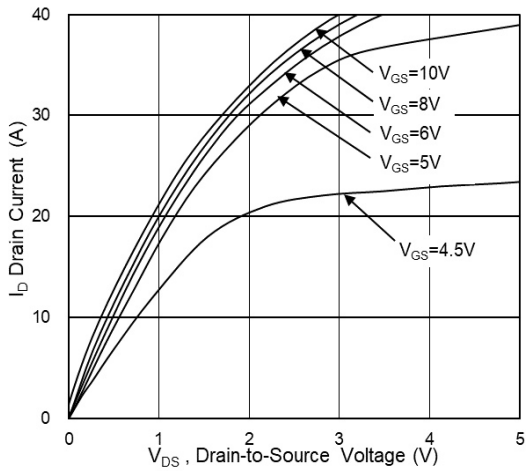

Fig.3 Source Drain Forward Characteristics

Fig.4 Gate-Charge Characteristics

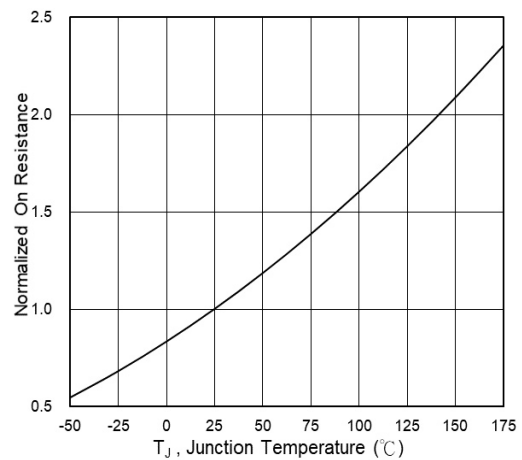
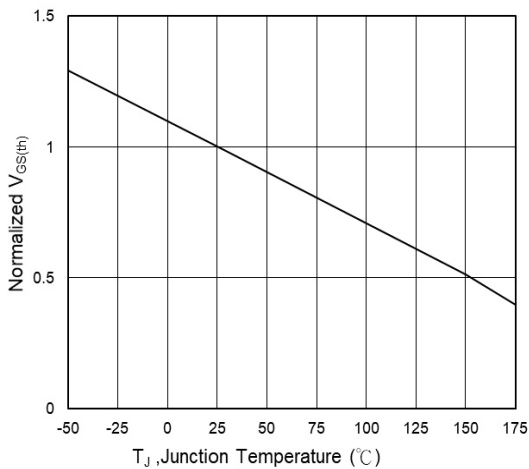

Fig.5 Normalized $V_{GS(th)}$ vs T_J

Fig.6 Normalized $R_{DS(on)}$ vs T_J

Single N-channel MOSFET

ELM4N20N15AFDA-N

<https://www.elm-tech.com>

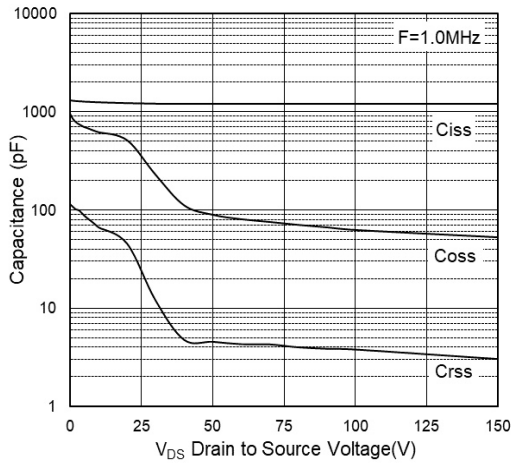

Fig.7 Capacitance

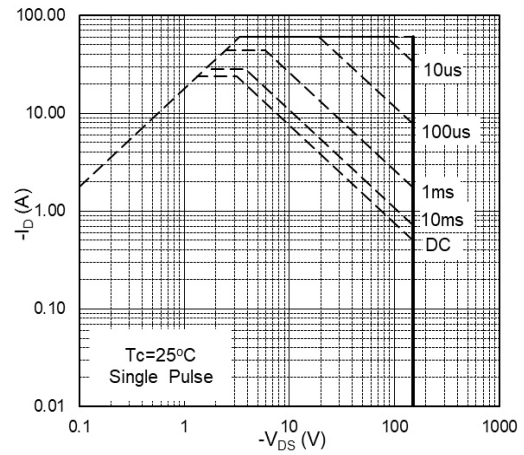

Fig.8 Safe Operating Area

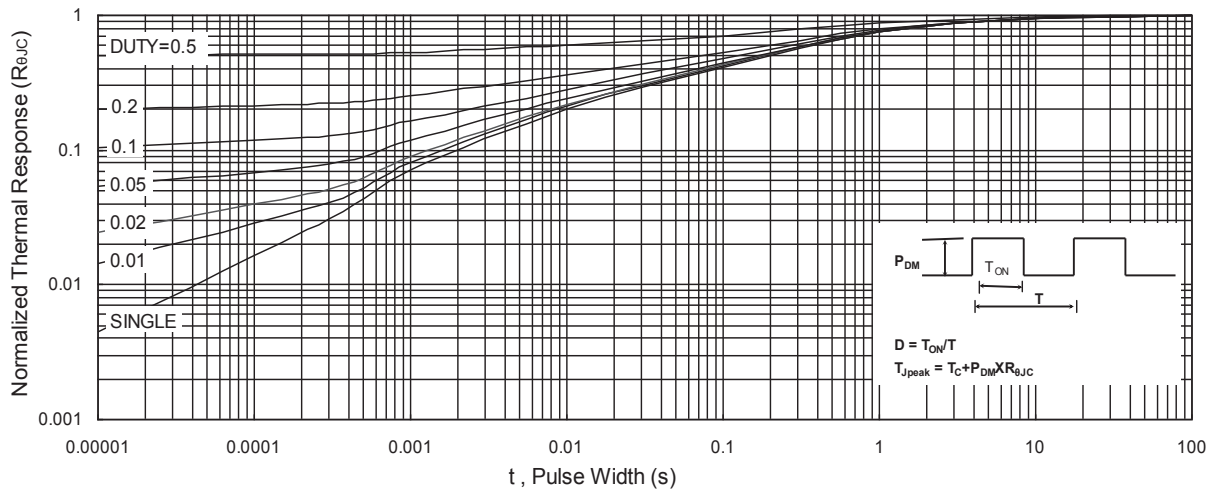

Fig.9 Normalized Maximum Transient Thermal Impedance

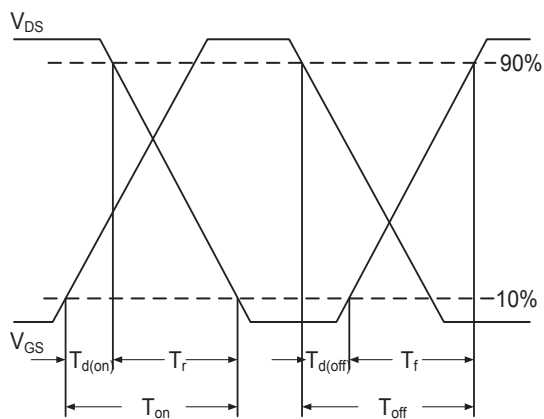

Fig.10 Switching Time Waveform

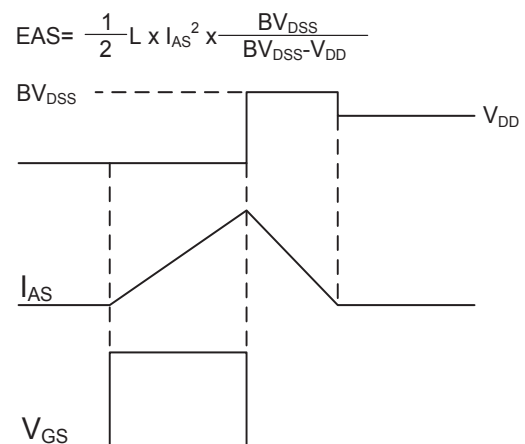

Fig.11 Unclamped Inductive Switching Waveform

Single N-channel MOSFET

ELM4N20N15AFDA-N

<https://www.elm-tech.com>

TO-252 dimension (2,500pcs/reel)

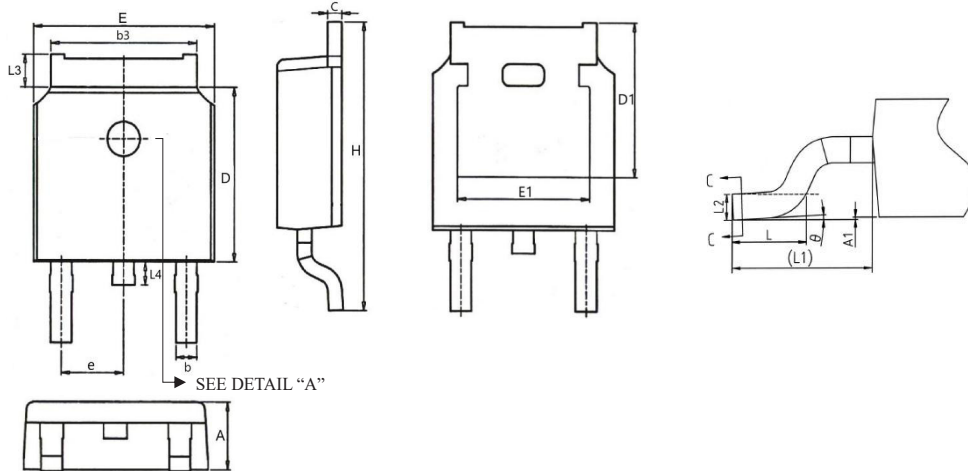

Detail "A"

	Top	Bottom		Top	Bottom
Option 1			Option 3		
Option 2			Option 4		

Symbols	Millimeters		Inches		Symbols	Millimeters		Inches	
	Min.	Max.	Min.	Max.		Min.	Max.	Min.	Max.
A	2.18	2.40	0.086	0.094	e	2.29 BSC		0.090 BSC	
A1	0.00	0.20	0.000	0.008	H	9.40	10.50	0.370	0.413
b	0.64	0.90	0.025	0.035	L	1.27	2.03	0.050	0.080
b3	4.95	5.50	0.195	0.217	L1	2.90 REF		0.114 REF	
c	0.43	0.61	0.017	0.024	L2	0.51 BSC		0.020 BSC	
D	5.90	6.30	0.232	0.248	L3	0.88	1.28	0.035	0.050
D1	5.30 REF		0.209 REF		L4	0.50	1.02	0.020	0.040
E	6.35	6.80	0.250	0.268	θ	0°	10°	0°	10°
E1	4.32	4.95	0.170	0.195					

Marking

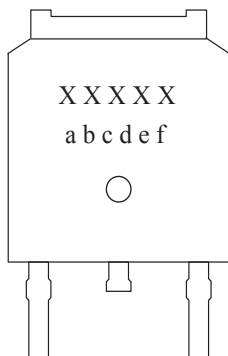

Symbols	Content
xxxxxx	Product code
a	Yearly code: 2019=K, 2020=L, 2021=M...
b, c	Weekly code: 01 to 53
d, e	Sequence: 01 to 99 or 0A to 0Z
f	Assembly code: A to Z (I, O excepted)