

Single N-channel MOSFET

ELM4N6004FDA-N

<http://www.elm-tech.com>

■ General description

ELM4N6004FDA-N uses advanced trench technology to provide excellent $R_{ds(on)}$, low gate charge and low gate threshold voltage.

■ Features

- $V_{ds}=60V$
- $I_d=23A$ ($V_{gs}=10V$)
- $R_{ds(on)} = 30m\Omega$ ($V_{gs}=10V$)
- $R_{ds(on)} = 38m\Omega$ ($V_{gs}=4.5V$)

■ Maximum absolute ratings

Parameter	Symbol	Limit	Unit	Note	
Drain-source voltage	V_{ds}	60	V		
Gate-source voltage	V_{gs}	± 20	V		
Continuous drain current	I_d	$T_c=25^\circ C$	23.0	A	1
		$T_c=100^\circ C$	15.0		
		$T_a=25^\circ C$	5.6		
		$T_a=70^\circ C$	4.5		
Pulsed drain current	I_{dm}	46	A	2	
Single pulsed avalanche energy	E_{as}	25.5	mJ	3	
Avalanche current	I_{as}	22.6	A		
Power dissipation	P_d	$T_c=25^\circ C$	34.7	W	4
		$T_a=25^\circ C$	2.0		
Junction and storage temperature range	T_j, T_{stg}	-55 to +150	$^\circ C$		

■ Thermal characteristics

Parameter	Symbol	Typ.	Max.	Unit	Note
Thermal resistance junction-to-ambient	$R_{\theta ja}$	-	62.0	$^\circ C/W$	1
Thermal resistance junction-to-case	$R_{\theta jc}$	-	3.6	$^\circ C/W$	1

■ Pin configuration

TO-252(TOP VIEW)

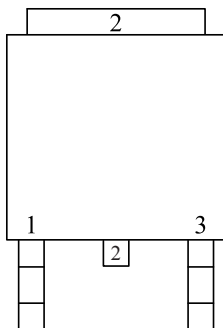

Pin No.	Pin name
1	GATE
2	DRAIN
3	SOURCE

■ Circuit

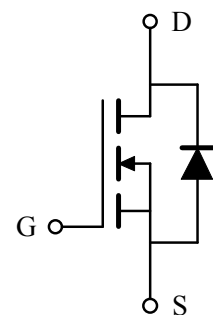

Single N-channel MOSFET

ELM4N6004FDA-N

<http://www.elm-tech.com>

■Electrical characteristics

T_j=25°C. Unless otherwise noted.

Parameter	Symbol	Condition	Min.	Typ.	Max.	Unit	Note
STATIC PARAMETERS							
Drain-source breakdown voltage	BV _{dss}	I _d =250μA, V _{gs} =0V	60	-	-	V	
Zero gate voltage drain current	I _{dss}	V _{ds} =48V, V _{gs} =0V	-	-	1	μA	
		V _{ds} =48V, V _{gs} =0V, T _j =55°C	-	-	5		
Gate-body leakage current	I _{gss}	V _{ds} =0V, V _{gs} =±20V	-	-	±100	nA	
Gate threshold voltage	V _{gs(th)}	V _{ds} =V _{gs} , I _d =250μA	1.2	-	2.5	V	
Static drain-source on-resistance	R _{ds(on)}	V _{gs} =10V, I _d =15A	-	25	30	mΩ	2
		V _{gs} =4.5V, I _d =10A	-	30	38		
Forward transconductance	G _{fs}	V _{ds} =5V, I _d =15A	-	17	-	S	
Diode forward voltage	V _{sd}	I _s =1A, V _{gs} =0V	-	-	1.2	V	2
Max. body-diode continuous current	I _s	V _{gs} =V _{ds} =0V, Force current	-	-	23	A	1, 5
Pulsed body-diode current	I _{sm}		-	-	46	A	2, 5
DYNAMIC PARAMETERS							
Input capacitance	C _{iss}	V _{gs} =0V, V _{ds} =15V, f=1MHz	-	1378	-	pF	
Output capacitance	C _{oss}		-	86	-	pF	
Reverse transfer capacitance	C _{rss}		-	64	-	pF	
Gate resistance	R _g	V _{ds} =0V, V _{gs} =0V, f=1MHz	-	3.2	-	Ω	
SWITCHING PARAMETERS							
Total gate charge (4.5V)	Q _g	V _{gs} =4.5V, V _{ds} =48V, I _d =12A	-	12.6	-	nC	
Gate-source charge	Q _{gs}		-	3.2	-	nC	
Gate-drain charge	Q _{gd}		-	6.3	-	nC	
Turn-on delay time	t _{d(on)}	V _{gs} =10V, V _{ds} =30V, I _d =10A R _{gen} =3.3Ω	-	8.0	-	ns	
Turn-on rise time	t _r		-	14.2	-	ns	
Turn-off delay time	t _{d(off)}		-	24.4	-	ns	
Turn-off fall time	t _f		-	4.6	-	ns	

NOTE :

1. The data tested by surface mounted on a 1 inch² FR-4 board with 2OZ copper.
2. The data tested by pulsed, pulse width ≤ 300μs and duty cycle ≤ 2%.
3. The Eas data shows Max. rating . The test condition is V_{dd}=25V, V_{gs}=10V, L=0.1mH, I_{as}=22.6A.
4. The power dissipation is limited by 150°C junction temperature.
5. The data is theoretically the same as I_d and I_{dm}, in real applications, should be limited by total power dissipation.

Single N-channel MOSFET

ELM4N6004FDA-N

<http://www.elm-tech.com>

■ Typical characteristics

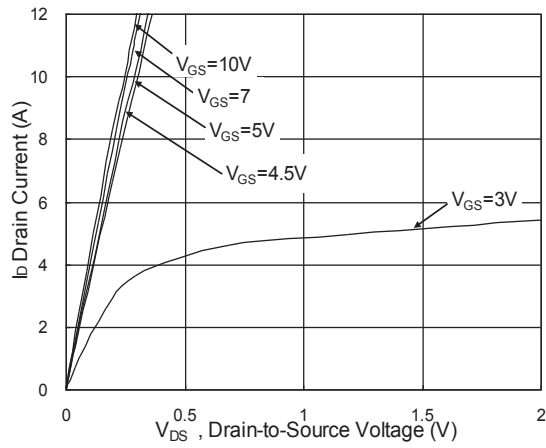

Fig.1 Typical Output Characteristics

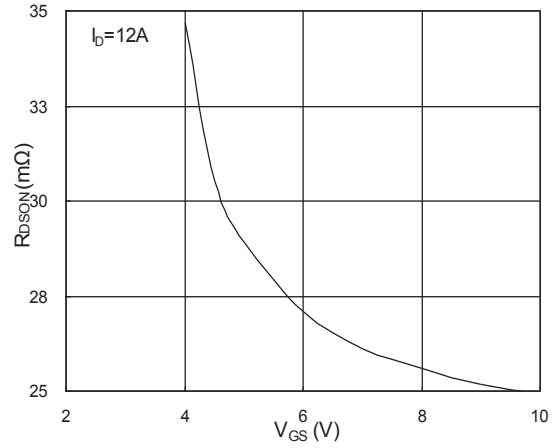

Fig.2 On-Resistance v.s Gate-Source

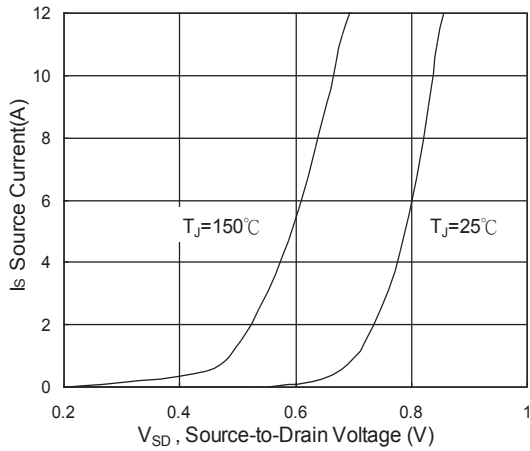

Fig.3 Forward Characteristics of Reverse

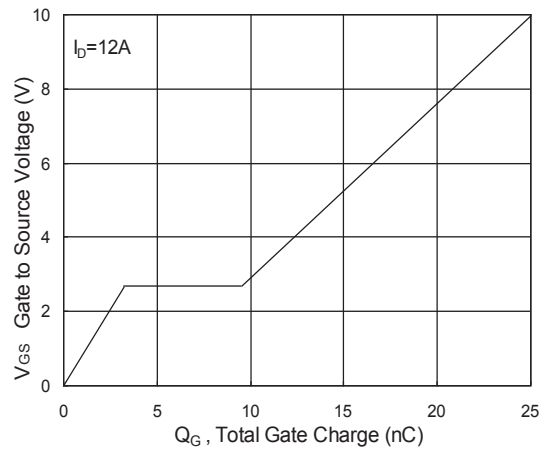

Fig.4 Gate-Charge Characteristics

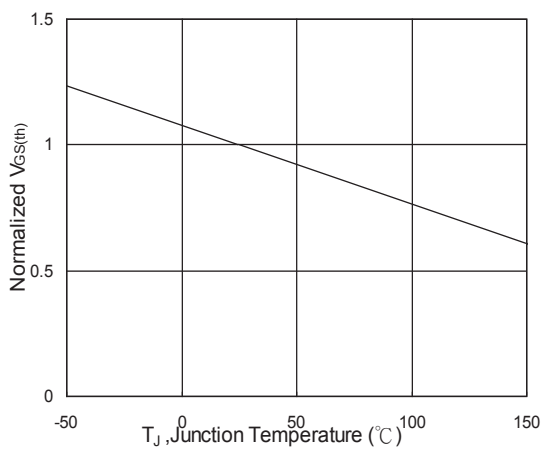

Fig.5 Normalized $V_{GS(th)}$ v.s T_J

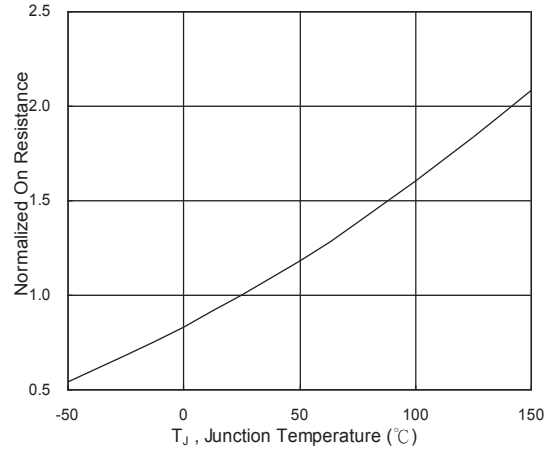

Fig.6 Normalized $R_{DS(on)}$ v.s T_J

Single N-channel MOSFET

ELM4N6004FDA-N

<http://www.elm-tech.com>

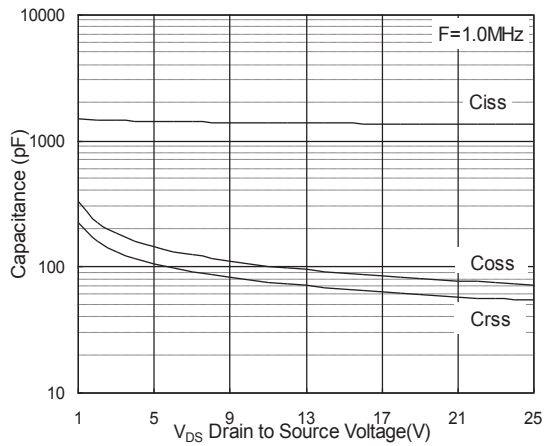

Fig.7 Capacitance

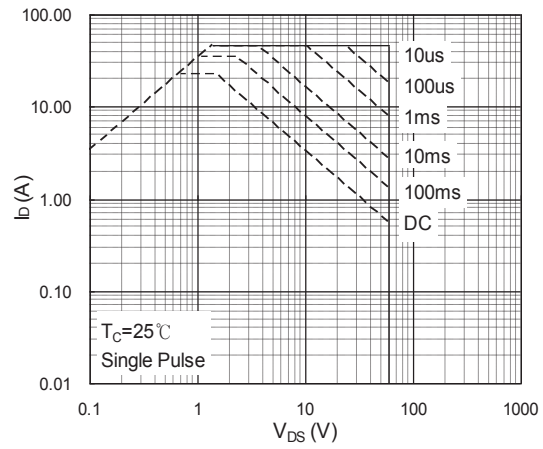

Fig.8 Safe Operating Area

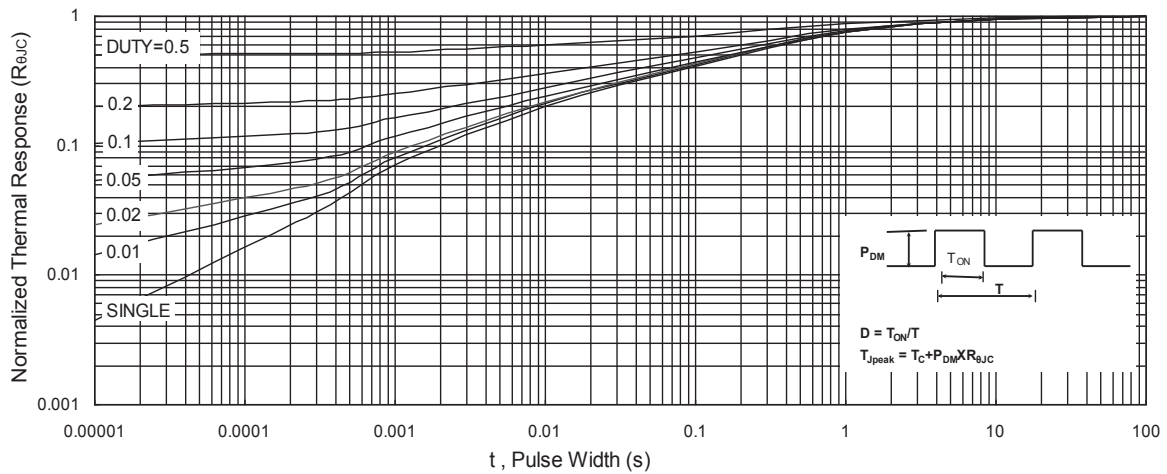

Fig.9 Normalized Maximum Transient Thermal Impedance

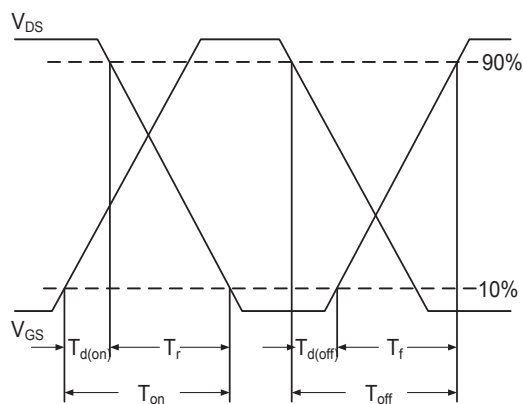

Fig.10 Switching Time Waveform

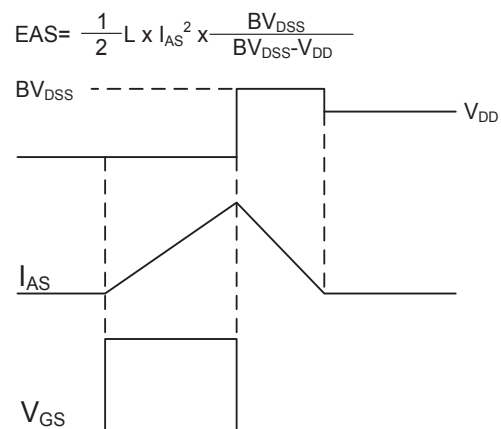

Fig.11 Unclamped Inductive Waveform