

# Single N-channel MOSFET

## ELM4N8066FDA-N

<https://www.elm-tech.com>

### ■ General description

ELM4N8066FDA-N uses advanced trench technology to provide excellent  $R_{ds(on)}$ , low gate charge and low gate threshold voltage.

### ■ Features

- $V_{ds}=80V$
- $I_d=60A$  ( $V_{gs}=10V$ )
- $R_{ds(on)} = 8.7m\Omega$  ( $V_{gs}=10V$ )
- $R_{ds(on)} = 12.5m\Omega$  ( $V_{gs}=4.5V$ )

### ■ Maximum absolute ratings

Parameter	Symbol	Limit	Unit	Note	
Drain-source voltage	$V_{ds}$	80	V		
Gate-source voltage	$V_{gs}$	$\pm 20$	V		
Continuous drain current ( $V_{gs}=10V$ )	$I_d$	$T_c=25^\circ C$	60	A	1
		$T_c=100^\circ C$	38		
Pulsed drain current	$I_{dm}$	200	A	2	
Single pulsed avalanche energy	$E_{as}$	101	mJ	3	
Avalanche current	$I_{as}$	45	A		
Total power dissipation	$P_d$	$T_c=25^\circ C$	52	W	4
Storage temperature range		$T_{stg}$	-55 to 150	$^\circ C$	
Operating junction temperature range	$T_j$	-55 to 150	$^\circ C$		

### ■ Thermal characteristics

Parameter	Symbol	Typ.	Max.	Unit	Note
Thermal resistance junction-ambient	$R_{\theta ja}$	--	62.0	$^\circ C/W$	1
Thermal resistance junction-case	$R_{\theta jc}$	--	2.4		

### ■ Pin configuration

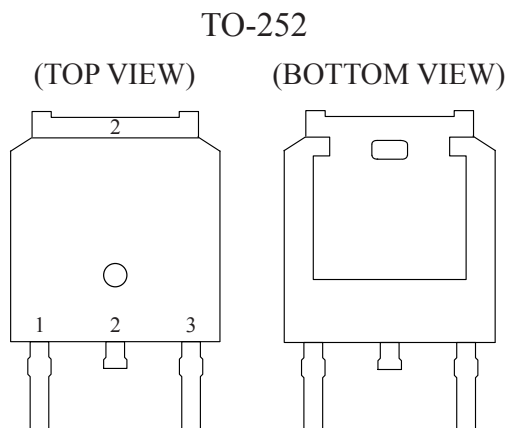

Pin No.	Pin name
1	GATE
2	DRAIN
3	SOURCE

### ■ Circuit

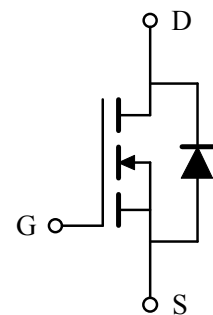

# Single N-channel MOSFET

## ELM4N8066FDA-N

<https://www.elm-tech.com>

### ■ Electrical characteristics

T<sub>j</sub>=25°C. Unless otherwise noted.

Parameter	Symbol	Condition	Min.	Typ.	Max.	Unit	Note
<b>STATIC PARAMETERS</b>							
Drain-source breakdown voltage	BV <sub>dss</sub>	V <sub>gs</sub> =0V, I <sub>d</sub> =250μA	80	--	--	V	
Static drain-source on-resistance	R <sub>ds(on)</sub>	V <sub>gs</sub> =10V, I <sub>d</sub> =15A	--	6.5	8.7	mΩ	2
		V <sub>gs</sub> =4.5V, I <sub>d</sub> =15A	--	9.0	12.5		
Gate threshold voltage	V <sub>gs(th)</sub>	V <sub>gs</sub> =V <sub>ds</sub> , I <sub>d</sub> =250μA	1.20	1.55	2.30	V	
Drain-source leakage current	I <sub>dss</sub>	V <sub>ds</sub> =64V, V <sub>gs</sub> =0V	--	--	1	μA	
		V <sub>ds</sub> =64V, V <sub>gs</sub> =0V, T <sub>j</sub> =55°C	--	--	5		
Gate-source leakage current	I <sub>gss</sub>	V <sub>gs</sub> =±20V, V <sub>ds</sub> =0V	--	--	±100	nA	
Continuous source current	I <sub>s</sub>	V <sub>gs</sub> =V <sub>ds</sub> =0V, Force current	--	--	30	A	1, 5
Diode forward voltage	V <sub>sd</sub>	V <sub>gs</sub> =0V, I <sub>s</sub> =1A	--	--	1.2	V	2
<b>DYNAMIC PARAMETERS</b>							
Input capacitance	C <sub>iss</sub>	V <sub>ds</sub> =40V, V <sub>gs</sub> =0V, f=1MHz	--	1738	--	pF	
Output capacitance	C <sub>oss</sub>		--	317	--	pF	
Reverse transfer capacitance	C <sub>rss</sub>		--	12	--	pF	
Gate resistance	R <sub>g</sub>	V <sub>ds</sub> =0V, V <sub>gs</sub> =0V, f=1MHz	--	1.6	--	Ω	
<b>SWITCHING PARAMETERS</b>							
Total gate charge	Q <sub>g</sub>	V <sub>ds</sub> =40V, V <sub>gs</sub> =10V I <sub>d</sub> =15A	--	29.0	--	nC	
Gate-source charge	Q <sub>gs</sub>		--	7.7	--	nC	
Gate-drain charge	Q <sub>gd</sub>		--	5.3	--	nC	
Turn-on delay time	t <sub>d(on)</sub>	V <sub>dd</sub> =40V, V <sub>gs</sub> =10V R <sub>gen</sub> =3.3Ω, I <sub>d</sub> =10A	--	6.2	--	ns	
Turn-on rise time	t <sub>r</sub>		--	19.0	--	ns	
Turn-off delay time	t <sub>d(off)</sub>		--	9.4	--	ns	
Turn-off fall time	t <sub>f</sub>		--	36.0	--	ns	
Reverse recovery time	t <sub>rr</sub>		I <sub>f</sub> =10A, di/dt=100A/μs	--	35	--	nS
Reverse recovery charge	Q <sub>rr</sub>	--		62	--	nC	

#### NOTE :

1. The data tested by surface mounted on a 1 inch<sup>2</sup> FR-4 board with 2OZ copper.
2. The data tested by pulsed, pulse width ≤ 300μs and duty cycle ≤ 2%.
3. The Eas data shows Max. rating . The test condition is V<sub>dd</sub>=50V, V<sub>gs</sub>=10V, L=0.1mH, I<sub>as</sub>=45A.
4. The power dissipation is limited by 150°C junction temperature.
5. The data is theoretically the same as I<sub>d</sub> and I<sub>dm</sub>, in real applications, should be limited by total power dissipation.

# Single N-channel MOSFET

## ELM4N8066FDA-N

<https://www.elm-tech.com>

### ■ Typical characteristics

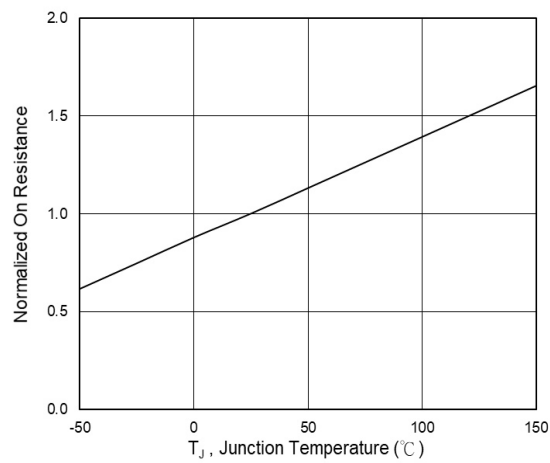
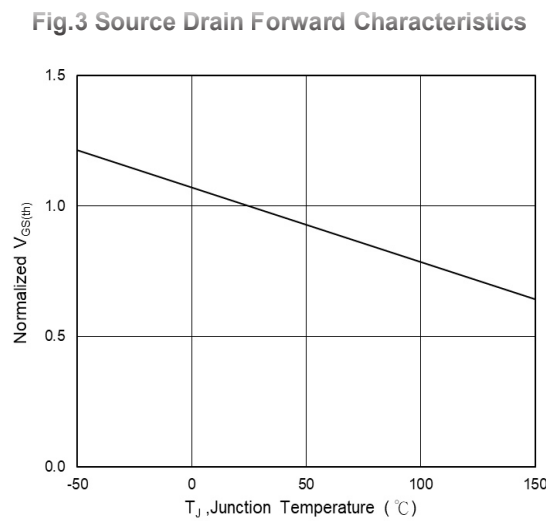
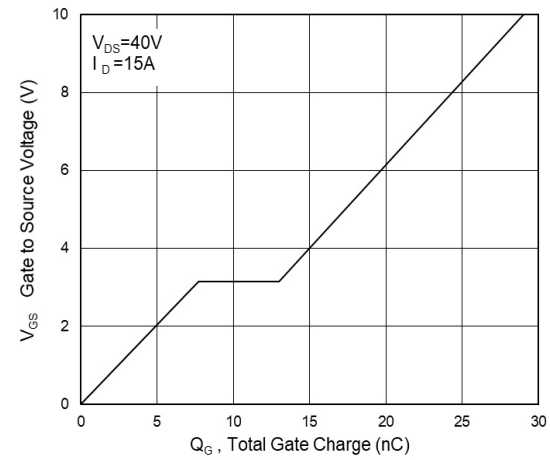
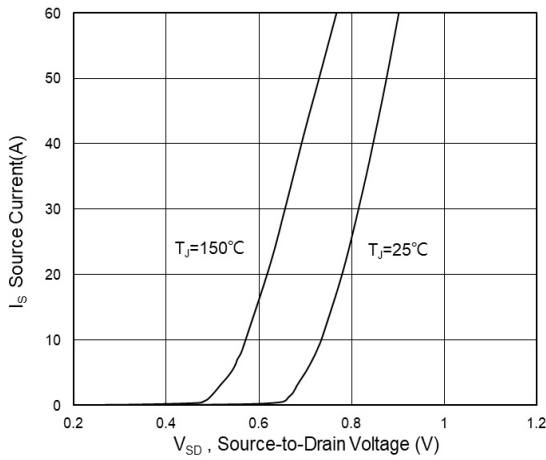
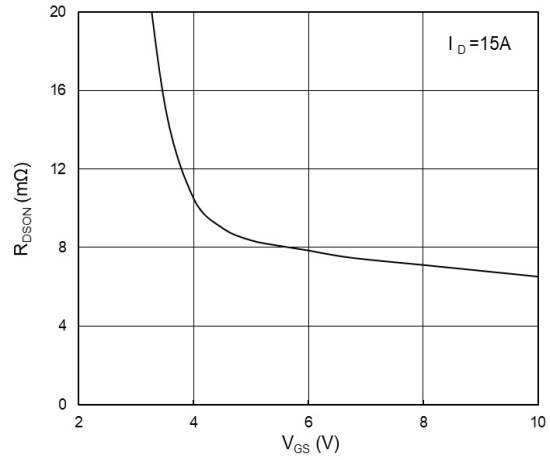
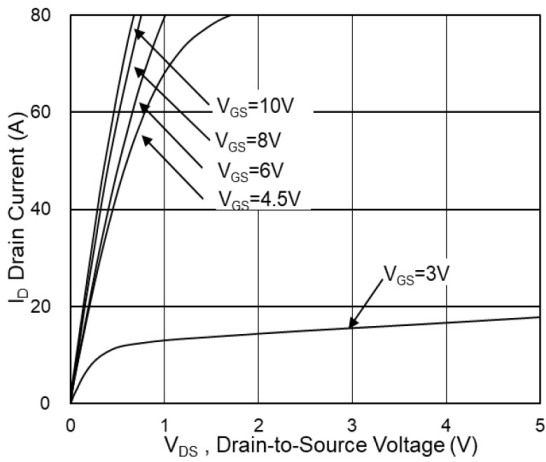

# Single N-channel MOSFET

## ELM4N8066FDA-N

<https://www.elm-tech.com>

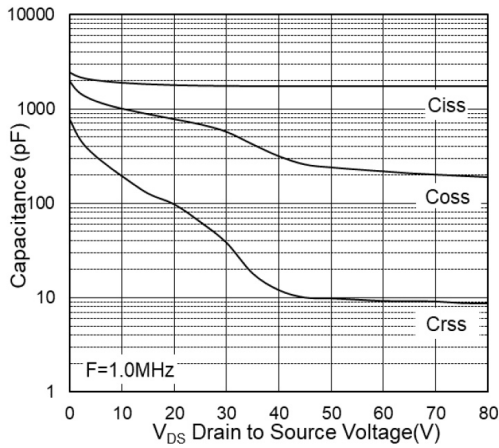

Fig.7 Capacitance

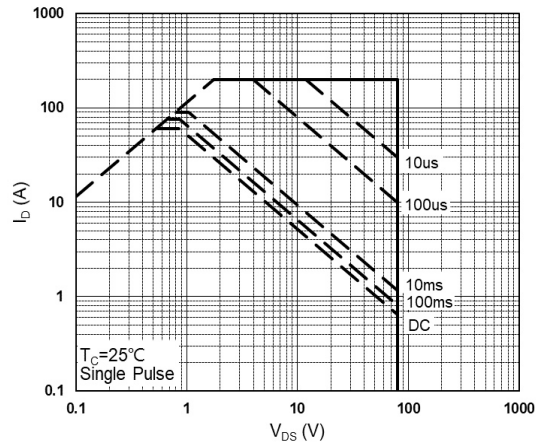

Fig.8 Safe Operating Area

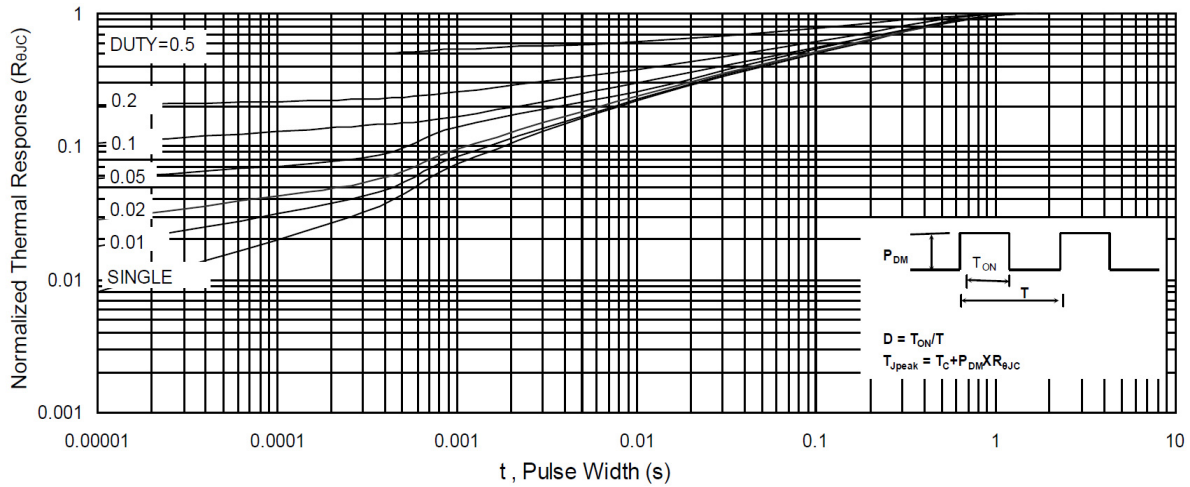

Fig.9 Normalized Maximum Transient Thermal Impedance

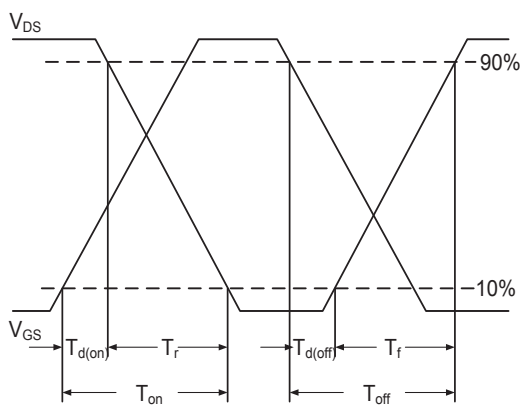

Fig.10 Switching Time Waveform

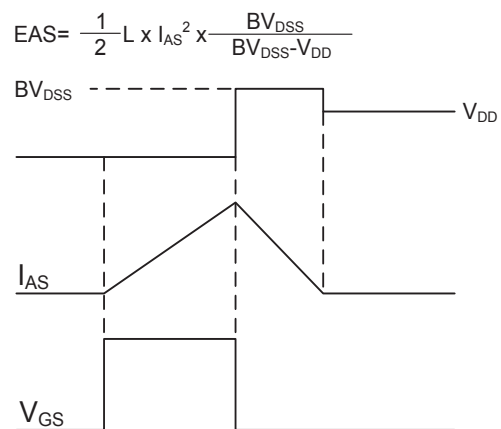

Fig.11 Unclamped Inductive Switching Waveform

# Single N-channel MOSFET

ELM4N8066FDA-N

<https://www.elm-tech.com>

## TO-252 dimension (2,500pcs/reel)

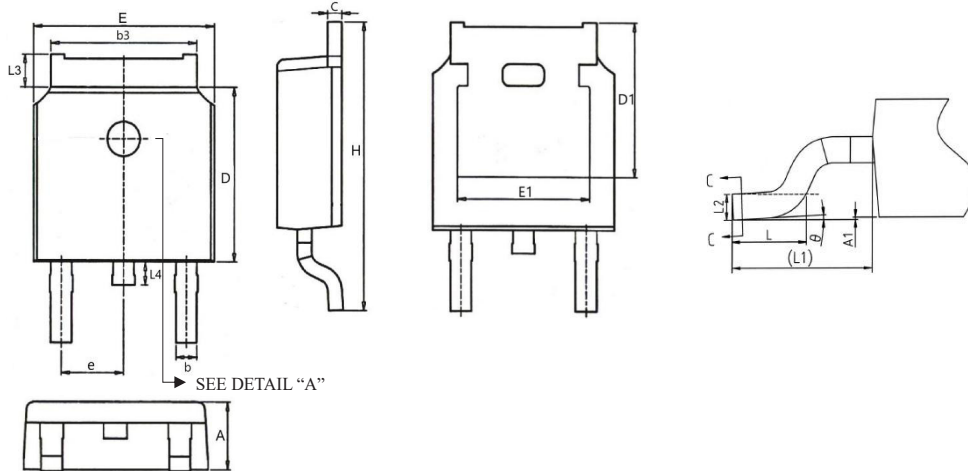

Detail "A"

	Top	Bottom		Top	Bottom
Option 1			Option 3		
Option 2			Option 4		

Symbols	Millimeters		Inches		Symbols	Millimeters		Inches	
	Min.	Max.	Min.	Max.		Min.	Max.	Min.	Max.
A	2.18	2.40	0.086	0.094	e	2.29 BSC		0.090 BSC	
A1	0.00	0.20	0.000	0.008	H	9.40	10.50	0.370	0.413
b	0.64	0.90	0.025	0.035	L	1.27	2.03	0.050	0.080
b3	4.95	5.50	0.195	0.217	L1	2.90 REF		0.114 REF	
c	0.43	0.61	0.017	0.024	L2	0.51 BSC		0.020 BSC	
D	5.90	6.30	0.232	0.248	L3	0.88	1.28	0.035	0.050
D1	5.30 REF		0.209 REF		L4	0.50	1.02	0.020	0.040
E	6.35	6.80	0.250	0.268	θ	0°	10°	0°	10°
E1	4.32	4.95	0.170	0.195					

## Marking

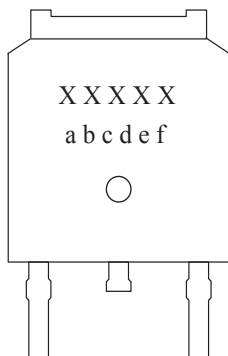

Symbols	Content
xxxxxx	Product code
a	Yearly code: 2019=K, 2020=L, 2021=M...
b, c	Weekly code: 01 to 53
d, e	Sequence: 01 to 99 or 0A to 0Z
f	Assembly code: A to Z (I, O excepted)