

Dual P-channel MOSFET

ELM52911WA-N

<http://www.elm-tech.com>

■ General description

ELM52911WA-N uses advanced trench technology to provide excellent $R_{ds(on)}$ and low gate charge.

■ Features

- $V_{ds} = -20V$
- $I_d = -4.5A$, $R_{ds(on)} = 96m\Omega$ ($V_{gs} = -4.5V$)
- $I_d = -3.8A$, $R_{ds(on)} = 128m\Omega$ ($V_{gs} = -2.5V$)
- $I_d = -2.5A$, $R_{ds(on)} = 180m\Omega$ ($V_{gs} = -1.8V$)

■ Maximum absolute ratings

$T_a = 25^\circ C$. Unless otherwise noted.

Parameter	Symbol	Limit	Unit
Drain-source voltage	V_{ds}	-20	V
Gate-source voltage	V_{gs}	± 12	V
Continuous drain current ($T_j = 150^\circ C$)	I_d	$T_a = 25^\circ C$	-4.5
		$T_a = 70^\circ C$	-3.8
Pulsed drain current	I_{dm}	-12	A
Power dissipation	P_d	$T_c = 25^\circ C$	6.5
		$T_c = 70^\circ C$	4.2
Operating junction temperature	T_j	150	$^\circ C$
Storage temperature range	T_{stg}	-55 to 150	$^\circ C$

■ Thermal characteristics

Parameter	Symbol	Typ.	Max.	Unit
Thermal resistance junction-to-ambient	$R_{\theta ja}$		120	$^\circ C/W$

■ Pin configuration

DFN6-2x2(TOP VIEW)

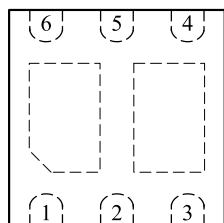

Pin No.	Pin name
1	SOURCE1
2	GATE1
3	DRAIN2
4	SOURCE2
5	GATE2
6	DRAIN1

■ Circuit

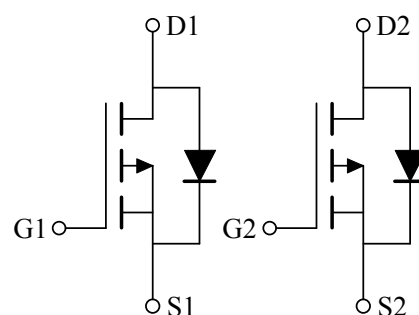

Dual P-channel MOSFET

ELM52911WA-N

<http://www.elm-tech.com>

■Electrical characteristics

Ta=25°C. Unless otherwise noted.

Parameter	Symbol	Condition	Min.	Typ.	Max.	Unit
STATIC PARAMETERS						
Drain-source breakdown voltage	BVdss	Id=-250μA, Vgs=0V	-20			V
Zero gate voltage drain current	Idss	Vds=-16V, Vgs=0V Ta=85°C			-1	μA
					-30	
Gate-body leakage current	Igss	Vds=0V, Vgs=±12V			±100	nA
Gate threshold voltage	Vgs(th)	Vds=Vgs, Id=-250μA	-0.3		-0.8	V
On state drain current	Id(on)	Vgs=-4.5V, Vds≥-5V	-8			A
		Vgs=-2.5V, Vds≥-5V	-3			
Static drain-source on-resistance	Rds(on)	Vgs=-4.5V, Id=-4.5A		86	96	mΩ
		Vgs=-2.5V, Id=-3.8A		114	128	
		Vgs=-1.8V, Id=-2.5A		150	180	
Forward transconductance	Gfs	Vds=-5V, Id=-2.8A		6.5		S
Diode forward voltage	Vsd	Is=-1.25A, Vgs=0V		-0.75	-1.30	V
Max. body-diode continuous current	Is				-1.6	A
DYNAMIC PARAMETERS						
Input capacitance	Ciss			375		pF
Output capacitance	Coss	Vgs=0V, Vds=-10V, f=1MHz		80		pF
Reverse transfer capacitance	Crss			60		pF
SWITCHING PARAMETERS						
Total gate charge	Qg	Vgs=-4.5V, Vds=-10V Id≐-3.5A		5.00	10.00	nC
Gate-source charge	Qgs			0.85		nC
Gate-drain charge	Qgd			1.50		nC
Turn-on delay time	td(on)	Vgs=-4.5V, Vds=-10V Id≐-3.5A, RL=2.85Ω Rgen=1Ω		15	25	ns
Turn-on rise time	tr			36	60	ns
Turn-off delay time	td(off)			25	50	ns
Turn-off fall time	tf			15	25	ns

Dual P-channel MOSFET

ELM52911WA-N

<http://www.elm-tech.com>

Typical electrical and thermal characteristics

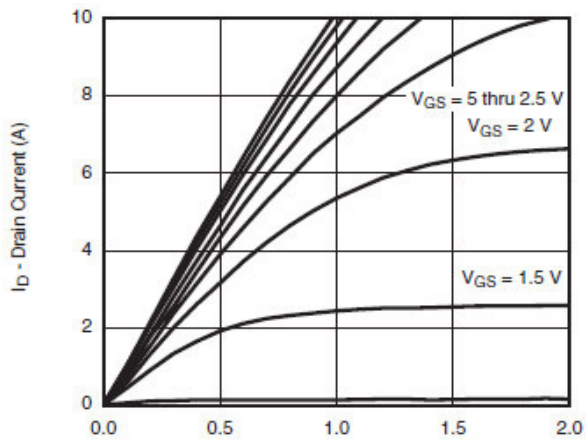

$V_{GS} = 5$ thru 2.5 V
 $V_{GS} = 2$ V
 $V_{GS} = 1.5$ V

Output Characteristics

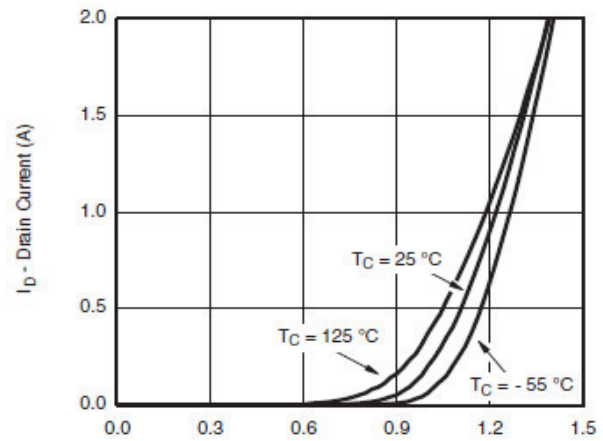

$T_C = 25^\circ\text{C}$
 $T_C = 125^\circ\text{C}$
 $T_C = -55^\circ\text{C}$

Transfer Characteristics

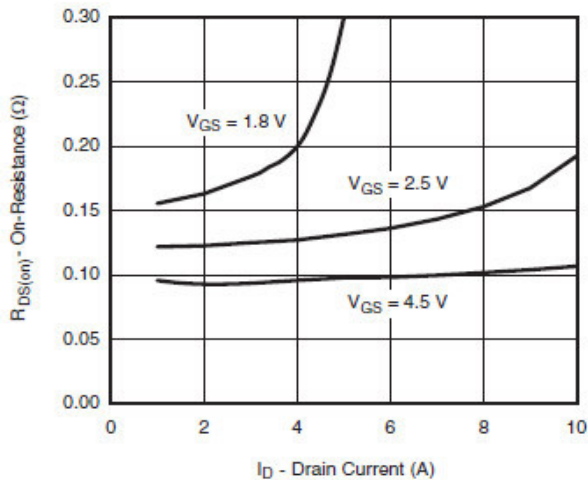

$V_{GS} = 1.8$ V
 $V_{GS} = 2.5$ V
 $V_{GS} = 4.5$ V

On-Resistance vs. Drain Current and Gate Voltage

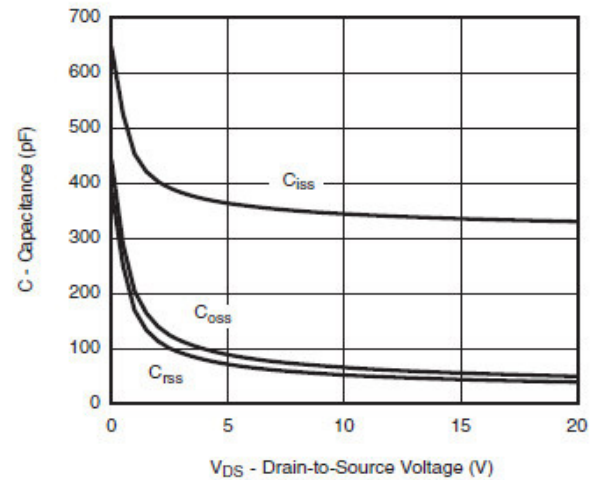

C_{iss}
 C_{oss}
 C_{rss}

Capacitance

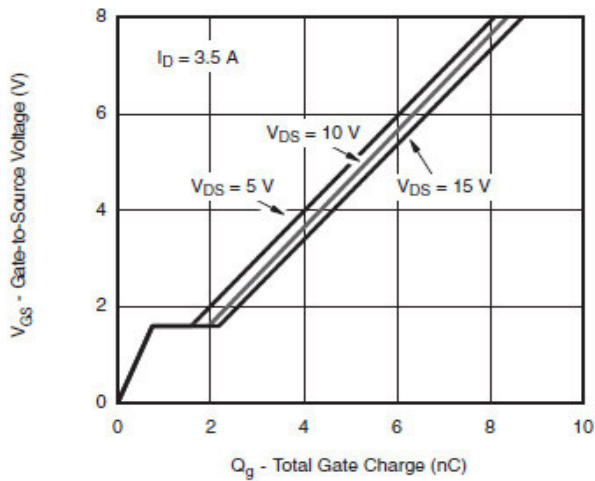

$I_D = 3.5$ A
 $V_{DS} = 10$ V
 $V_{DS} = 5$ V
 $V_{DS} = 15$ V

Gate Charge

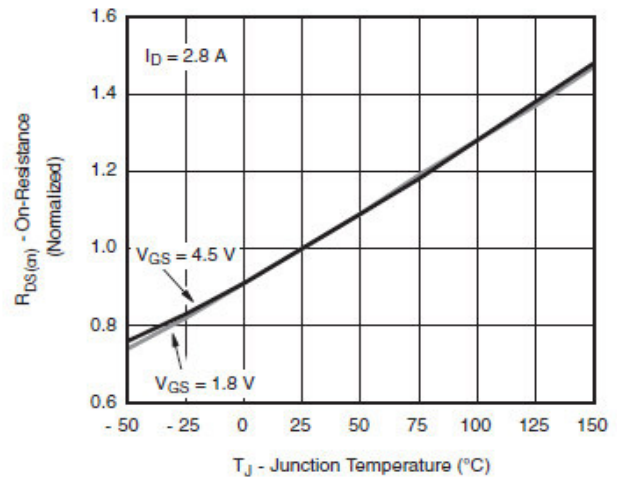

$I_D = 2.8$ A
 $V_{GS} = 4.5$ V
 $V_{GS} = 1.8$ V

On-Resistance vs. Junction Temperature

Dual P-channel MOSFET

ELM52911WA-N

<http://www.elm-tech.com>

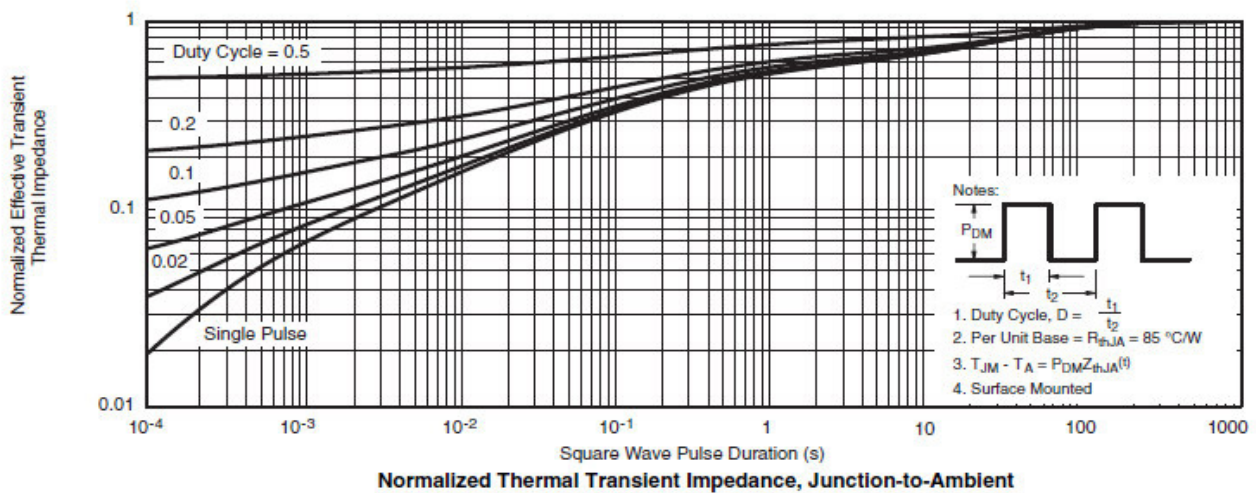
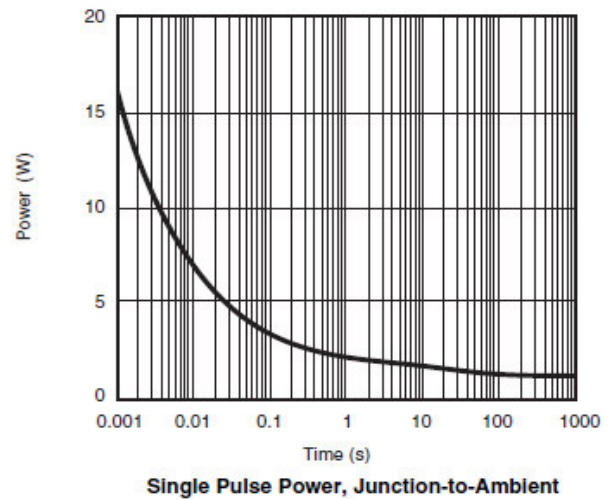
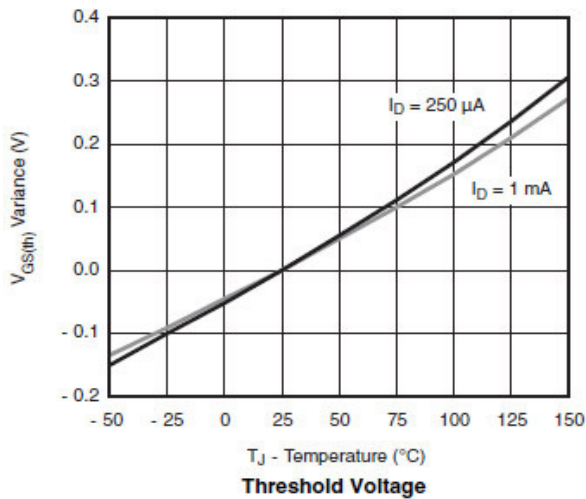
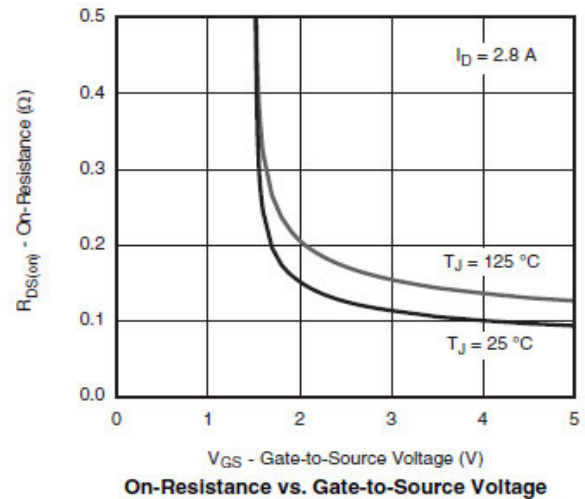
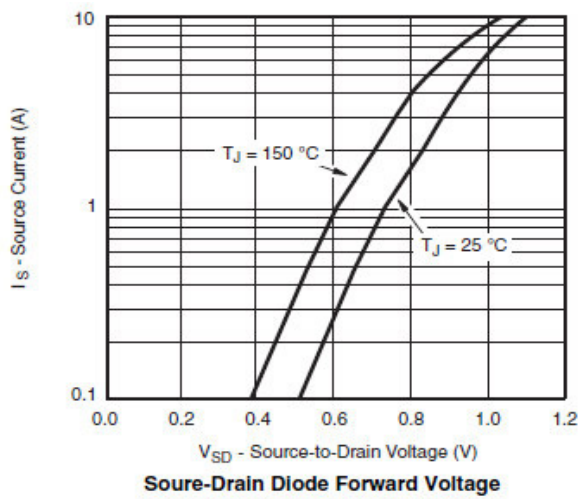

Dual P-channel MOSFET

ELM52911WA-N

<http://www.elm-tech.com>

■ Test circuit & waveform

Gate Charge Test Circuit & Waveform

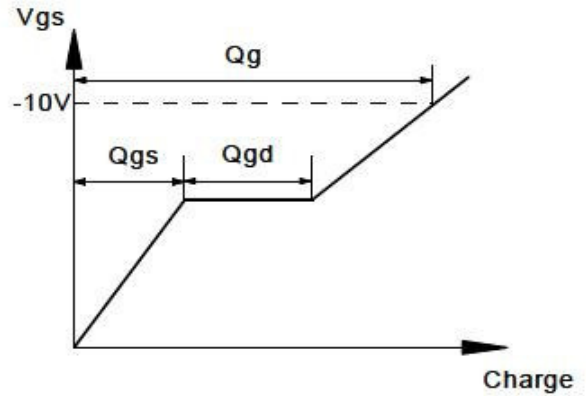
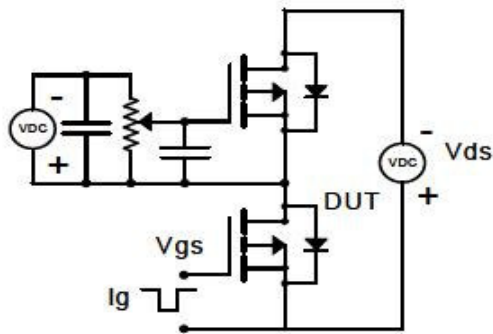

Resistive Switching Test Circuit & Waveforms

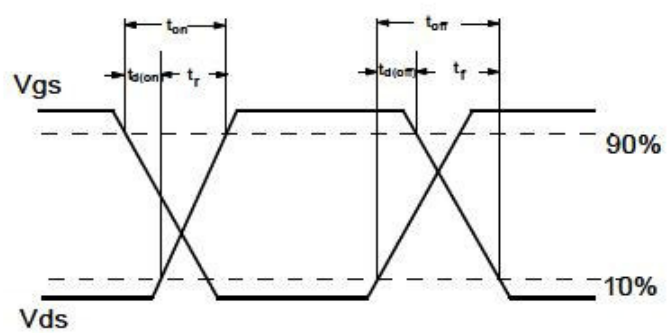
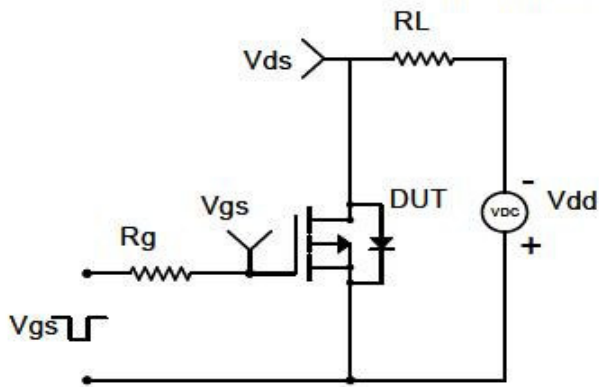

Diode Recovery Test Circuit & Waveforms

