

Dual N-channel MOSFET

ELM54944WSA-N

<http://www.elm-tech.com>

■ General description

ELM54944WSA-N uses advanced trench technology to provide excellent $R_{ds(on)}$ and low gate charge.

■ Features

- $V_{ds}=30V$
- $I_d=12A$
- $R_{ds(on)} = 14m\Omega$ ($V_{gs}=10V$)
- $R_{ds(on)} = 17m\Omega$ ($V_{gs}=4.5V$)

■ Maximum absolute ratings

$T_a=25^\circ C$. Unless otherwise noted.

Parameter	Symbol	Limit	Unit
Drain-source voltage	V_{ds}	30	V
Gate-source voltage	V_{gs}	± 20	V
Continuous drain current($T_j=150^\circ C$)	I_d	$T_a=25^\circ C$	12
		$T_a=70^\circ C$	9
Pulsed drain current	I_{dm}	30	A
Power dissipation	P_d	$T_c=25^\circ C$	2.8
		$T_c=70^\circ C$	1.8
Operating junction temperature	T_j	150	$^\circ C$
Storage temperature range	T_{stg}	-55 to 150	$^\circ C$

■ Thermal characteristics

Parameter	Symbol	Typ.	Max.	Unit
Thermal resistance junction-to-ambient	$R_{\theta ja}$		62.5	$^\circ C/W$

■ Pin configuration

SOP-8(TOP VIEW)

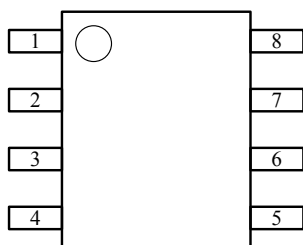

Pin No.	Pin name
1	SOURCE1
2	GATE1
3	SOURCE2
4	GATE2
5	DRAIN2
6	DRAIN2
7	DRAIN1
8	DRAIN1

■ Circuit

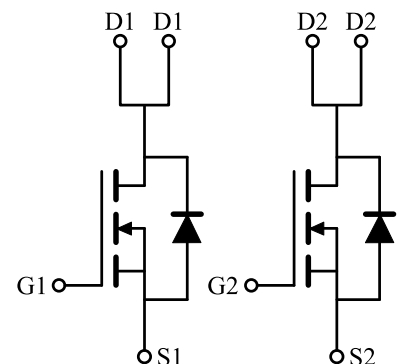

Dual N-channel MOSFET

ELM54944WSA-N

<http://www.elm-tech.com>

■ Electrical characteristics

Ta=25°C. Unless otherwise noted.

Parameter	Symbol	Condition	Min.	Typ.	Max.	Unit
STATIC PARAMETERS						
Drain-source breakdown voltage	BVdss	Id=250μA, Vgs=0V	30			V
Zero gate voltage drain current	Idss	Vds=24V Vgs=0V			1	μA
		Ta=85°C			10	
Gate-body leakage current	Igss	Vds=0V, Vgs=±20V			±100	nA
Gate threshold voltage	Vgs(th)	Vds=Vgs, Id=250μA	1.0		2.0	V
On state drain current	Id(on)	Vgs=10V, Vds≥5V	30			A
Static drain-source on-resistance	Rds(on)	Vgs=10V, Id=12A		12	14	mΩ
		Vgs=4.5V, Id=10A		15	17	
Forward transconductance	Gfs	Vds=10V, Id=12A		32		S
Diode forward voltage	Vsd	Is=12A, Vgs=0V		0.8	1.3	V
Max. body-diode continuous current	Is				1.5	A
DYNAMIC PARAMETERS						
Input capacitance	Ciss	Vgs=0V, Vds=15V, f=1MHz		1080		pF
Output capacitance	Coss			180		pF
Reverse transfer capacitance	Crss			100		pF
SWITCHING PARAMETERS						
Total gate charge	Qg	Vgs=10V, Vds=15V Id≐11A		18	35	nC
Gate-source charge	Qgs			6		nC
Gate-drain charge	Qgd			4		nC
Turn-on delay time	td(on)	Vgs=10V, Vds=15V, Id≐1A RL=15Ω, Rgen=6Ω		10	20	ns
Turn-on rise time	tr			10	20	ns
Turn-off delay time	td(off)			40	70	ns
Turn-off fall time	tf			12	25	ns

Dual N-channel MOSFET

ELM54944WSA-N

<http://www.elm-tech.com>

Typical electrical and thermal characteristics

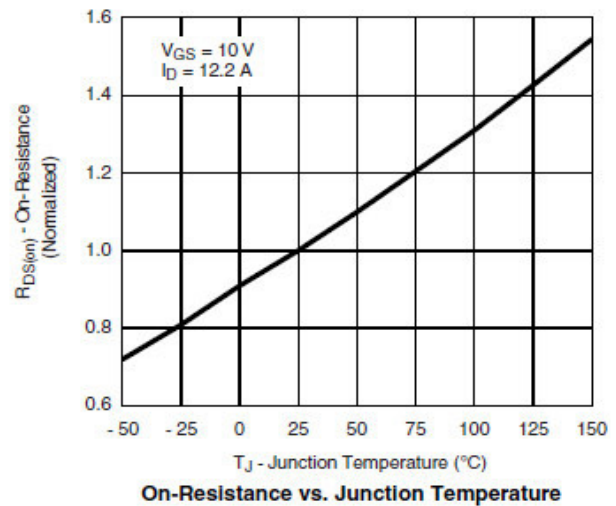
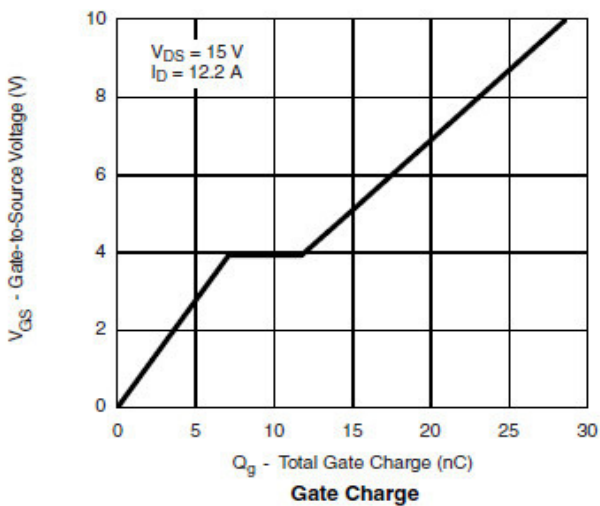
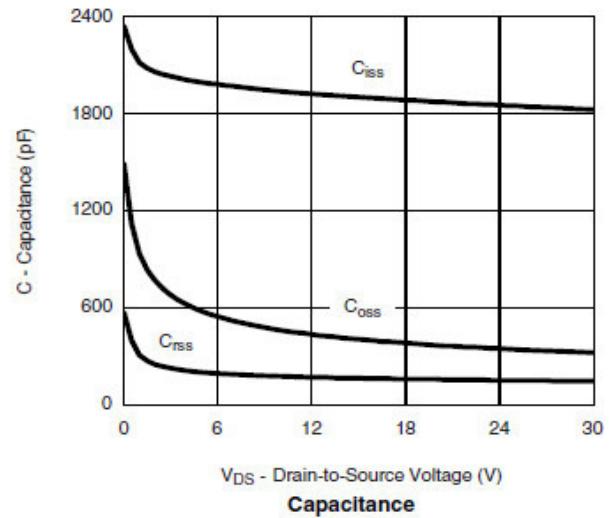
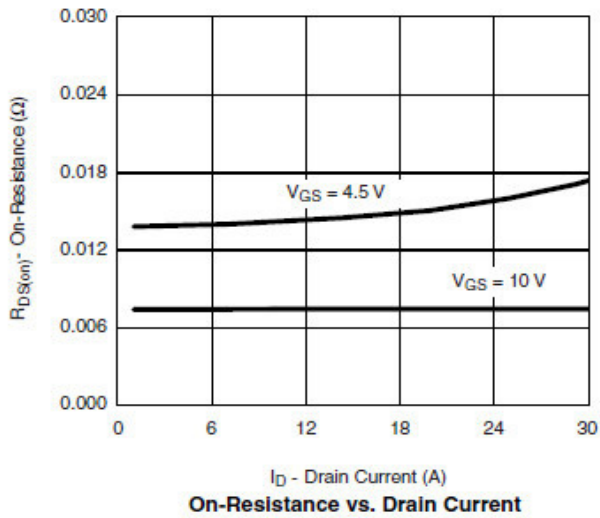
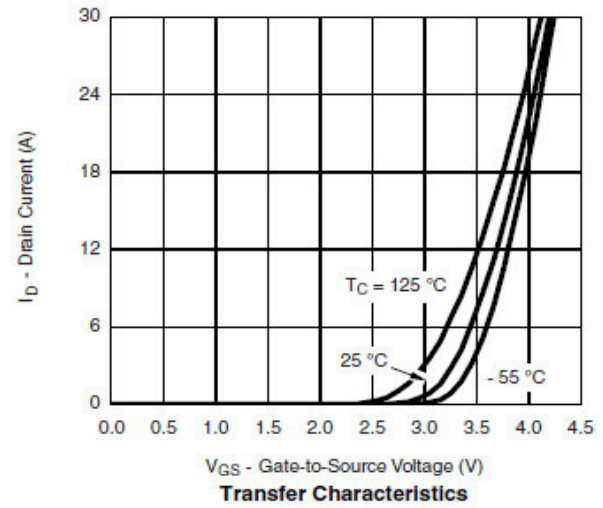
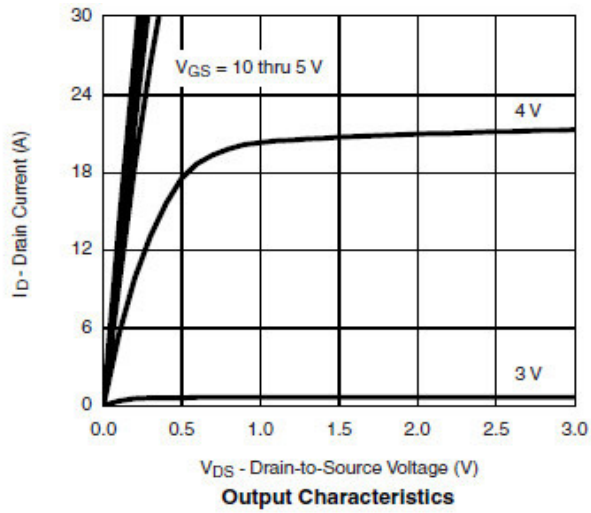

Dual N-channel MOSFET

ELM54944WSA-N

<http://www.elm-tech.com>

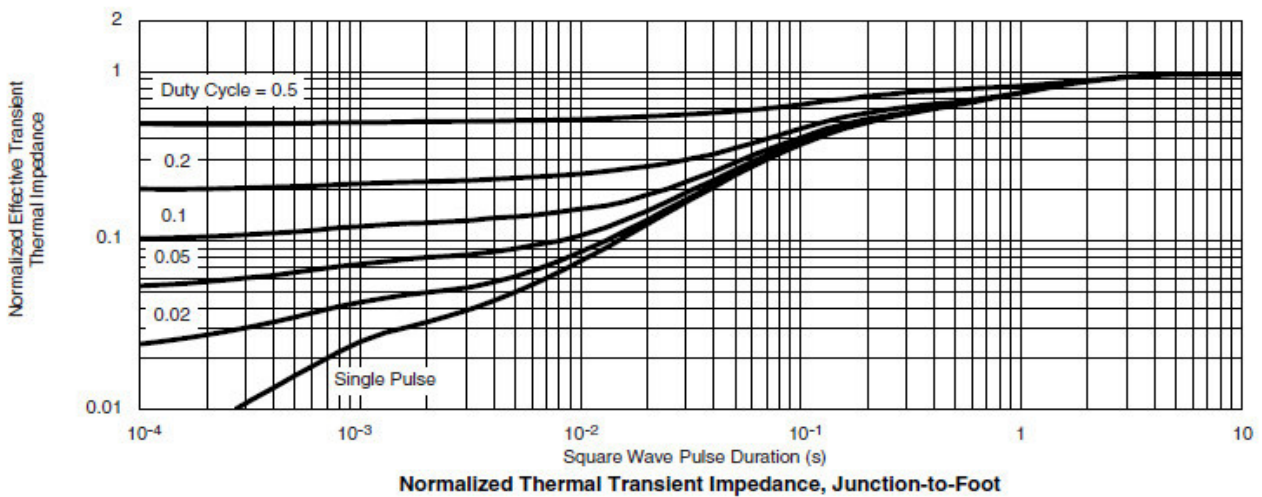
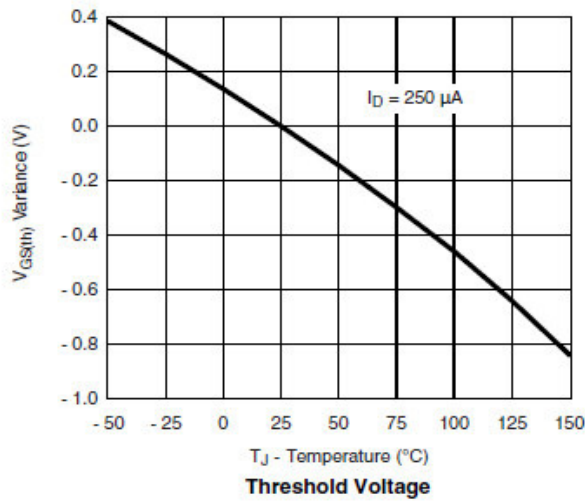
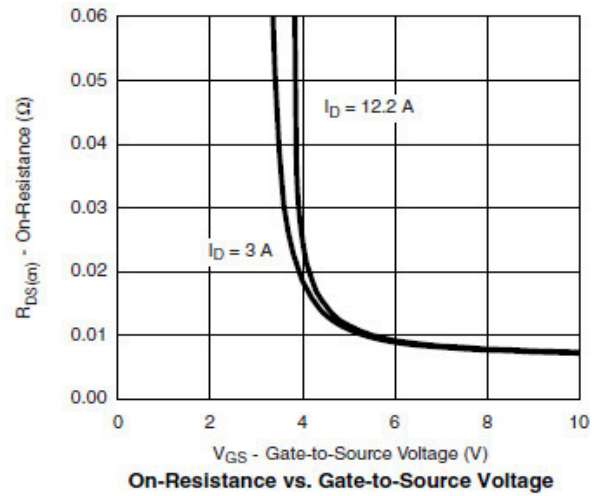
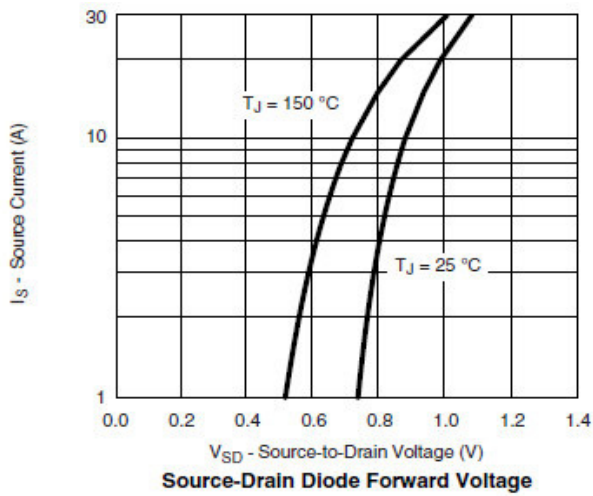

Dual N-channel MOSFET

ELM54944WSA-N

<http://www.elm-tech.com>

■ Test circuit and waveform

Gate Charge Test Circuit & Waveform

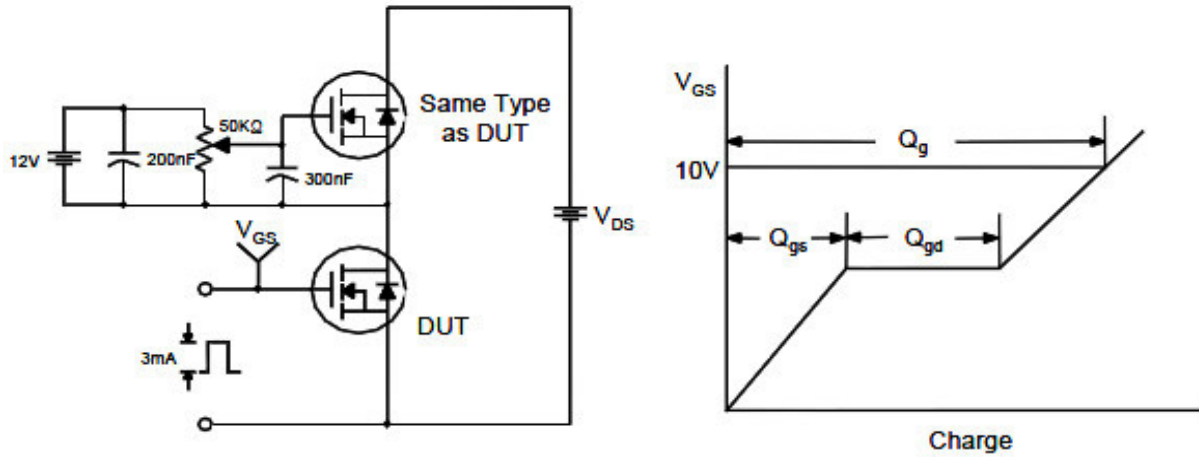

Resistive Switching Test Circuit & Waveforms

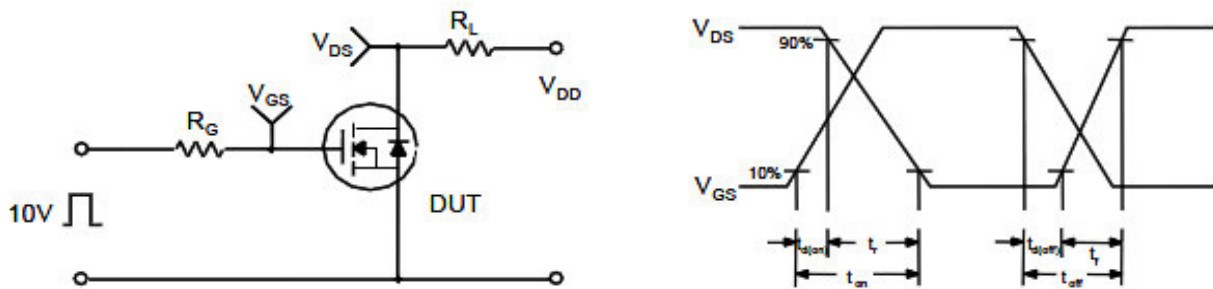

Unclamped Inductive Switching Test Circuit & Waveforms

