

# Dual N-channel MOSFET

## ELM54946WA-N

<http://www.elm-tech.com>

### ■ General description

ELM54946WA-N uses advanced trench technology to provide excellent  $R_{ds(on)}$  and low gate charge.

### ■ Features

- $V_{ds}=60V$
- $I_d=6.8A$
- $R_{ds(on)} = 42m\Omega$  ( $V_{gs}=10V$ )
- $R_{ds(on)} = 48m\Omega$  ( $V_{gs}=4.5V$ )

### ■ Maximum absolute ratings

$T_a=25^\circ C$ . Unless otherwise noted.

Parameter	Symbol	Limit	Unit
Drain-source voltage	$V_{ds}$	60	V
Gate-source voltage	$V_{gs}$	$\pm 20$	V
Continuous drain current( $T_j=150^\circ C$ )	$I_d$	$T_a=25^\circ C$	6.8
		$T_a=70^\circ C$	5.6
Pulsed drain current	$I_{dm}$	30	A
Power dissipation	$P_d$	$T_c=25^\circ C$	2.8
		$T_c=70^\circ C$	1.8
Operating junction temperature	$T_j$	150	$^\circ C$
Storage temperature range	$T_{stg}$	-55 to 150	$^\circ C$

### ■ Thermal characteristics

Parameter	Symbol	Typ.	Max.	Unit
Thermal resistance junction-to-ambient	$R_{\theta ja}$		62.5	$^\circ C/W$

### ■ Pin configuration

SOP-8(TOP VIEW)

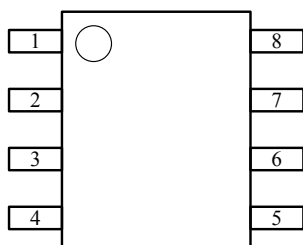

Pin No.	Pin name
1	SOURCE1
2	GATE1
3	SOURCE2
4	GATE2
5	DRAIN2
6	DRAIN2
7	DRAIN1
8	DRAIN1

### ■ Circuit

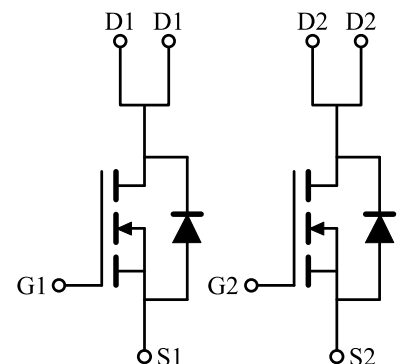

# Dual N-channel MOSFET

## ELM54946WA-N

<http://www.elm-tech.com>

### ■ Electrical characteristics

Ta=25°C. Unless otherwise noted.

Parameter	Symbol	Condition	Min.	Typ.	Max.	Unit
<b>STATIC PARAMETERS</b>						
Drain-source breakdown voltage	BVdss	Id=250μA, Vgs=0V	60			V
Zero gate voltage drain current	Idss	Vds=60V Vgs=0V			1	μA
		Ta=85°C			5	
Gate-body leakage current	Igss	Vds=0V, Vgs=±20V			±100	nA
Gate threshold voltage	Vgs(th)	Vds=Vgs, Id=250μA	1.0		2.5	V
On state drain current	Id(on)	Vgs=4.5V, Vds≥5V	30			A
Static drain-source on-resistance	Rds(on)	Vgs=10V, Id=6.8A		38	42	mΩ
		Vgs=4.5V, Id=5.6A		42	48	
Forward transconductance	Gfs	Vds=15V, Id=5.3A		24		S
Diode forward voltage	Vsd	Is=2.0A, Vgs=0V		0.8	1.2	V
Max. body-diode continuous current	Is				1.5	A
<b>DYNAMIC PARAMETERS</b>						
Input capacitance	Ciss	Vgs=0V, Vds=30V, f=1MHz		890		pF
Output capacitance	Coss			85		pF
Reverse transfer capacitance	Crss			48		pF
<b>SWITCHING PARAMETERS</b>						
Total gate charge	Qg	Vgs=5.0V, Vds=30V Id=5.6A		10.0	15.0	nC
Gate-source charge	Qgs			3.5		nC
Gate-drain charge	Qgd			3.6		nC
Turn-on delay time	td(on)	Vgs=4.5V, Vds=30V, Id=5.0A RL=6.8Ω, Rgen=6.0Ω		10	15	ns
Turn-on rise time	tr			12	20	ns
Turn-off delay time	td(off)			25	35	ns
Turn-off fall time	tf			10	15	ns

# Dual N-channel MOSFET

ELM54946WA-N

<http://www.elm-tech.com>

## ■ Typical electrical and thermal characteristics

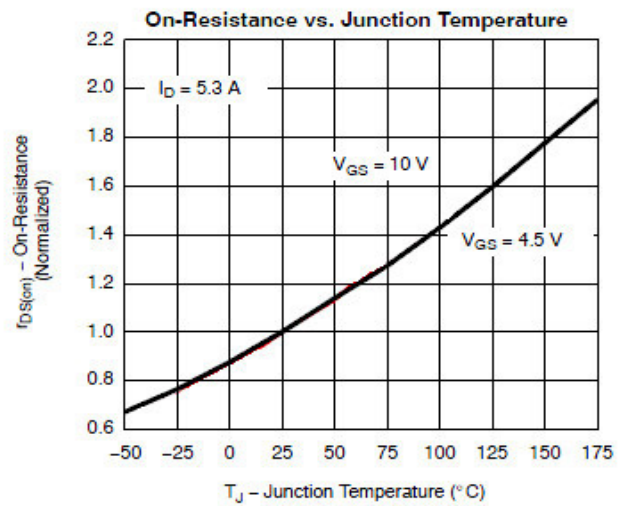
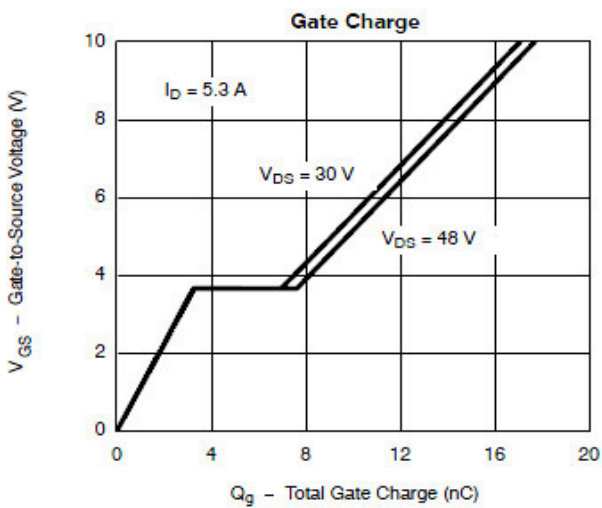
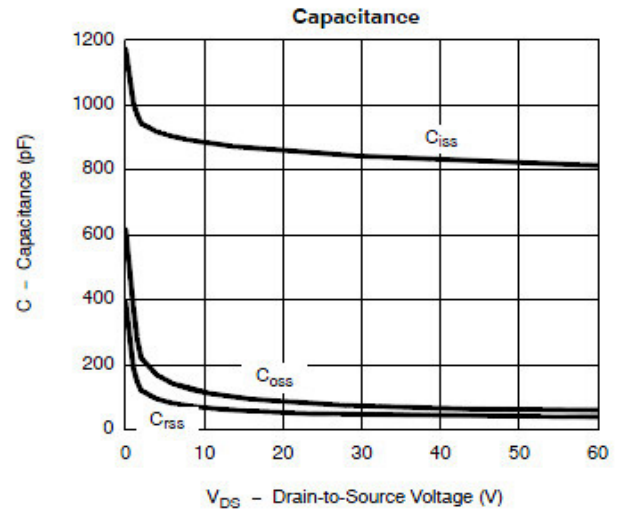
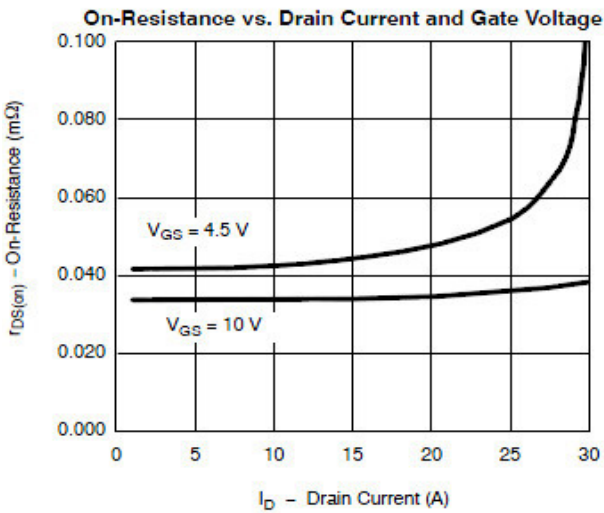
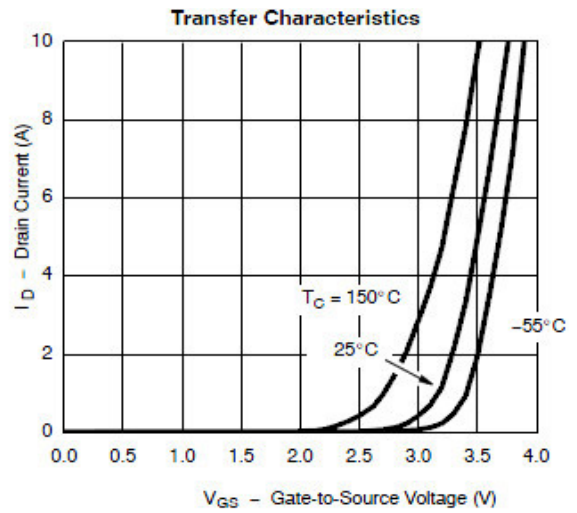
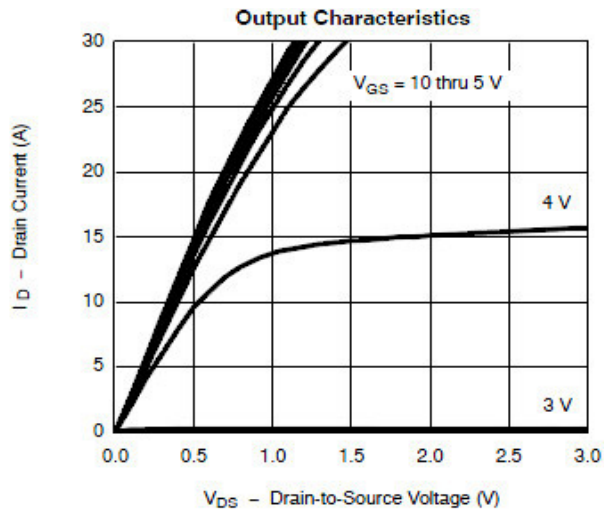

# Dual N-channel MOSFET

## ELM54946WA-N

<http://www.elm-tech.com>

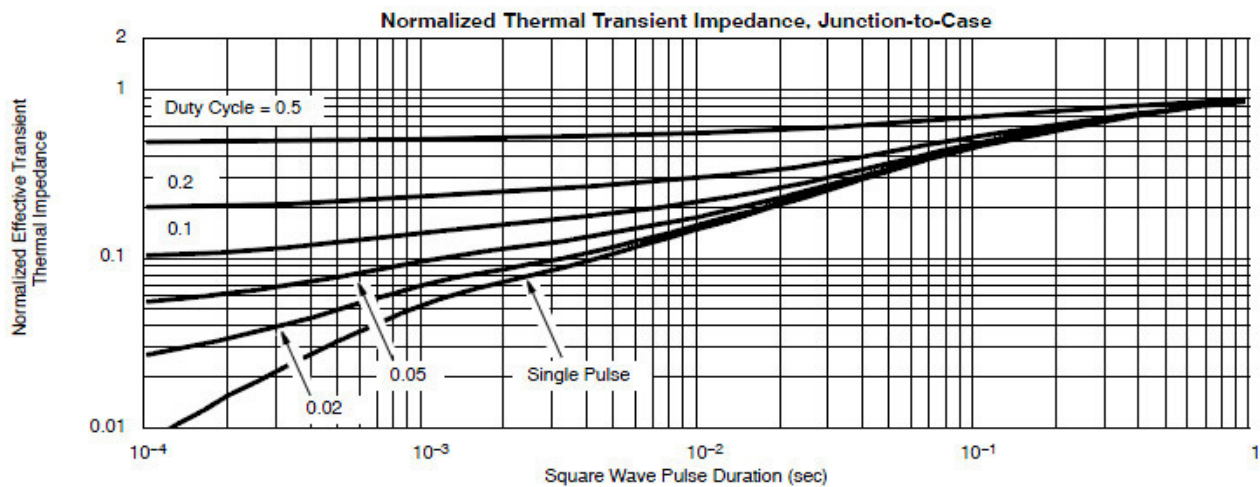
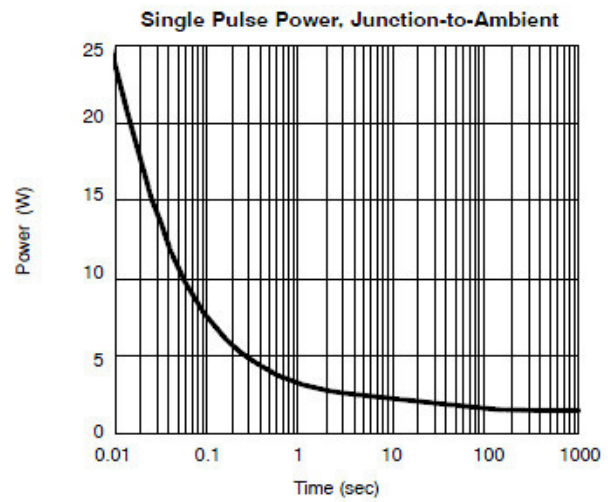
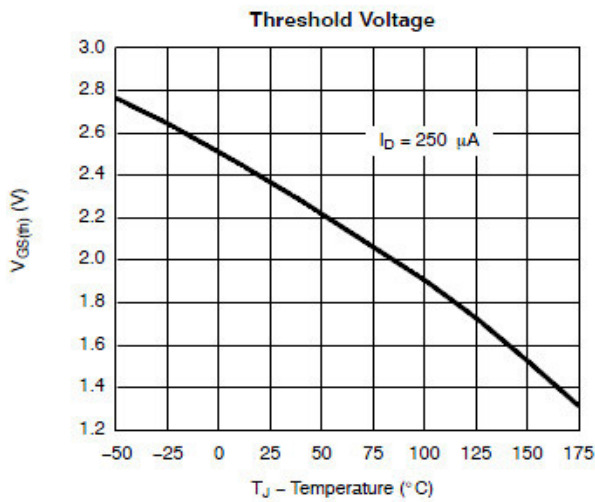
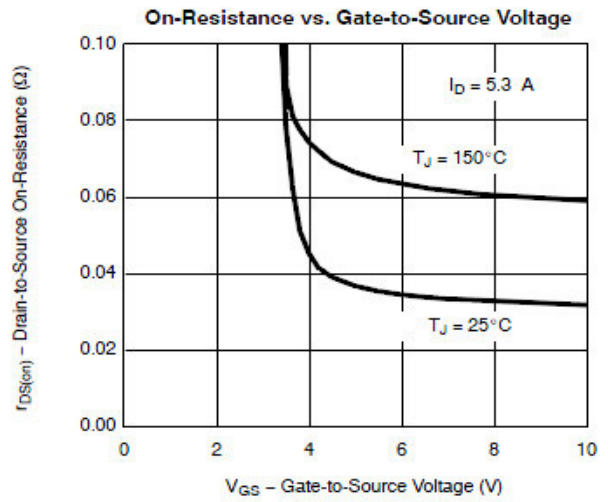
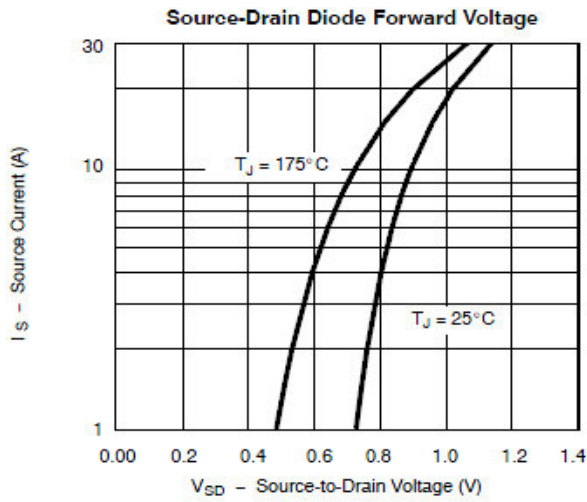

# Dual N-channel MOSFET

ELM54946WA-N

<http://www.elm-tech.com>

## ■ Test circuit and waveform

Gate Charge Test Circuit & Waveform

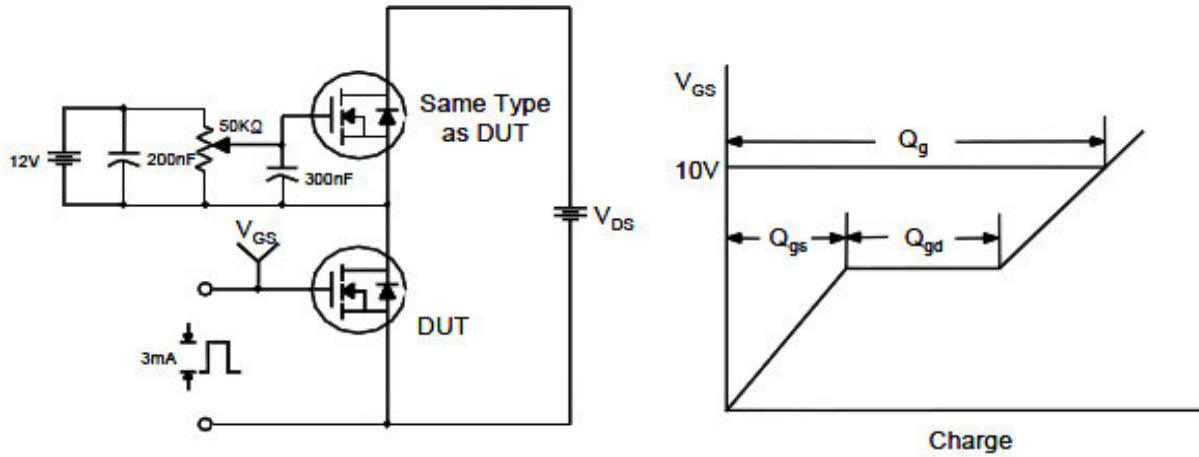

Resistive Switching Test Circuit & Waveforms

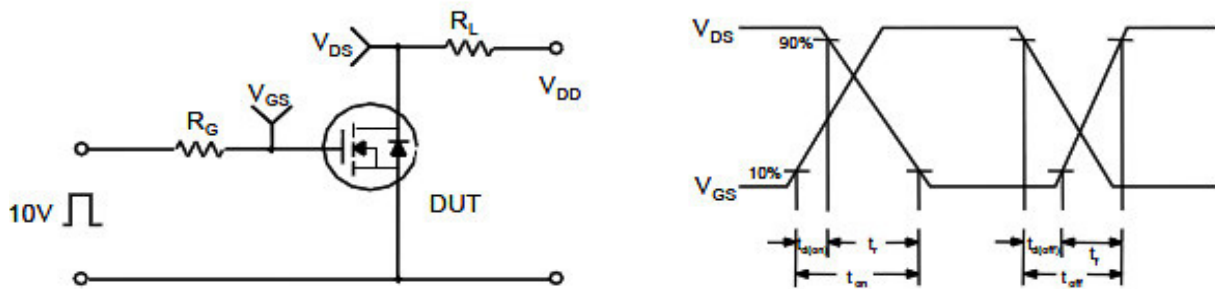

Unclamped Inductive Switching Test Circuit & Waveforms

