

Dual P-channel MOSFET

ELM57923WSA-N

<http://www.elm-tech.com>

■ General description

ELM57923WSA-N uses advanced trench technology to provide excellent $R_{ds(on)}$ and low gate charge.

■ Features

- $V_{ds} = -30V$
- $I_d = -8.0A$
- $R_{ds(on)} = 55m\Omega$ ($V_{gs} = -10V$)
- $R_{ds(on)} = 75m\Omega$ ($V_{gs} = -4.5V$)
- $R_{ds(on)} = 95m\Omega$ ($V_{gs} = -2.5V$)

■ Maximum absolute ratings

$T_a = 25^\circ C$. Unless otherwise noted.

Parameter	Symbol	Limit	Unit
Drain-source voltage	V_{ds}	-30	V
Gate-source voltage	V_{gs}	± 12	V
Continuous drain current ($T_j = 150^\circ C$)	I_d	$T_a = 25^\circ C$	-8.0
		$T_a = 70^\circ C$	-6.0
Pulsed drain current	I_{dm}	-30	A
Power dissipation	P_d	$T_c = 25^\circ C$	1.8
		$T_c = 70^\circ C$	1.2
Operating junction temperature	T_j	150	$^\circ C$
Storage temperature range	T_{stg}	-55 to 150	$^\circ C$

■ Thermal characteristics

Parameter	Symbol	Typ.	Max.	Unit
Thermal resistance junction-to-ambient	$R_{\theta ja}$		62.5	$^\circ C/W$

■ Pin configuration

DFN8-3x3(TOP VIEW)

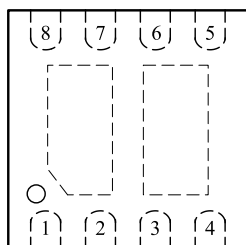

Pin No.	Pin name
1	SOURCE1
2	GATE1
3	SOURCE2
4	GATE2
5	DRAIN2
6	DRAIN2
7	DRAIN1
8	DRAIN1

■ Circuit

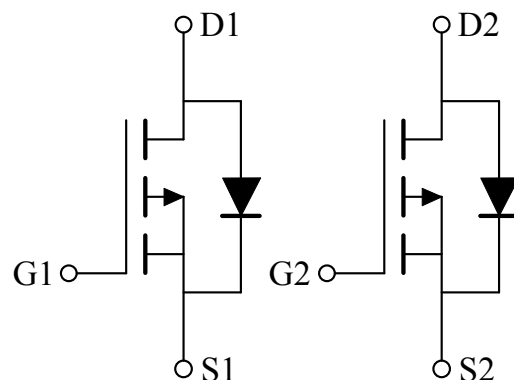

Dual P-channel MOSFET

ELM57923WSA-N

<http://www.elm-tech.com>

■Electrical characteristics

Ta=25°C. Unless otherwise noted.

Parameter	Symbol	Condition	Min.	Typ.	Max.	Unit
STATIC PARAMETERS						
Drain-source breakdown voltage	BVdss	Id=-250μA, Vgs=0V	-30			V
Zero gate voltage drain current	Idss	Vds=-24V, Vgs=0V Ta=85°C			-1	μA
					-30	
Gate-body leakage current	Igss	Vds=0V, Vgs=±12V			±100	nA
Gate threshold voltage	Vgs(th)	Vds=Vgs, Id=-250μA	-0.6		-1.1	V
On state drain current	Id(on)	Vgs=-10V, Vds≥-5V	-25			A
Static drain-source on-resistance	Rds(on)	Vgs=-10V, Id=-8.0A		40	55	mΩ
		Vgs=-4.5V, Id=-6.0A		58	75	
		Vgs=-2.5V, Id=-4.0A		78	95	
Forward transconductance	Gfs	Vds=-10V, Id=-4.9A		10		S
Diode forward voltage	Vsd	Is=-1.7A, Vgs=0V		-0.8	-1.3	V
Max. body-diode continuous current	Is				-10	A
DYNAMIC PARAMETERS						
Input capacitance	Ciss	Vgs=0V, Vds=-15V, f=1MHz		500		pF
Output capacitance	Coss			100		pF
Reverse transfer capacitance	Crss			55		pF
SWITCHING PARAMETERS						
Total gate charge	Qg	Vgs=-10V, Vds=-15V Id≐-5.0A		10.0	18.0	nC
Gate-source charge	Qgs			1.6		nC
Gate-drain charge	Qgd			3.0		nC
Turn-on delay time	td(on)	Vgs=-10V, Vds=-15V Id≐-1.0A, RL=15Ω Rgen=6Ω		8	18	ns
Turn-on rise time	tr			8	18	ns
Turn-off delay time	td(off)			25	50	ns
Turn-off fall time	tf			25	35	ns

Dual P-channel MOSFET

ELM57923WSA-N

<http://www.elm-tech.com>

Typical electrical and thermal characteristics

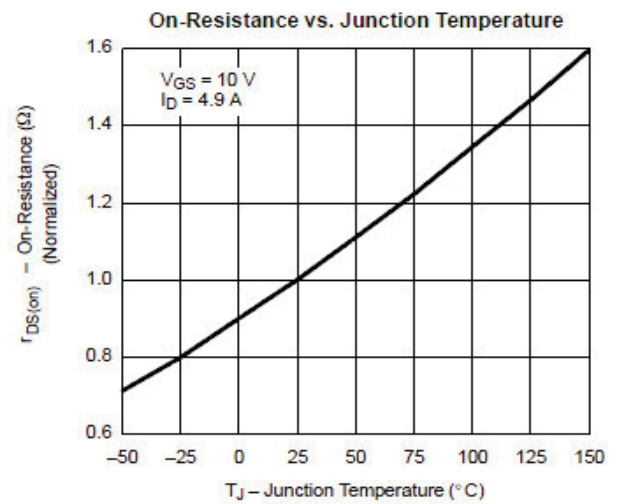
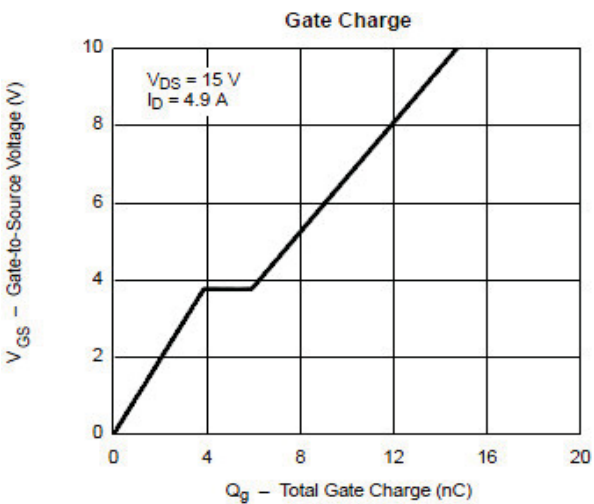
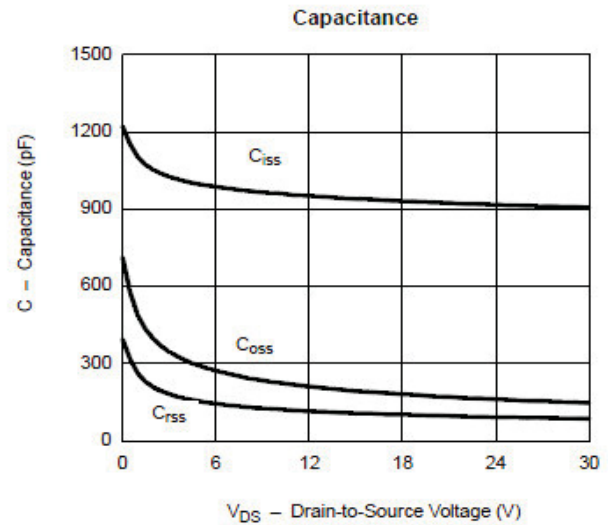
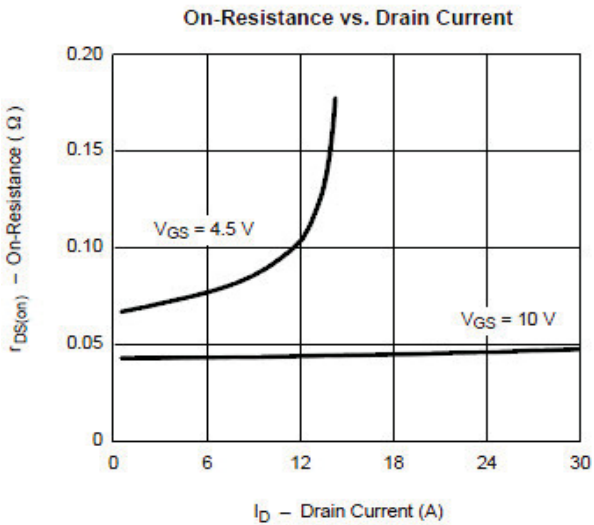
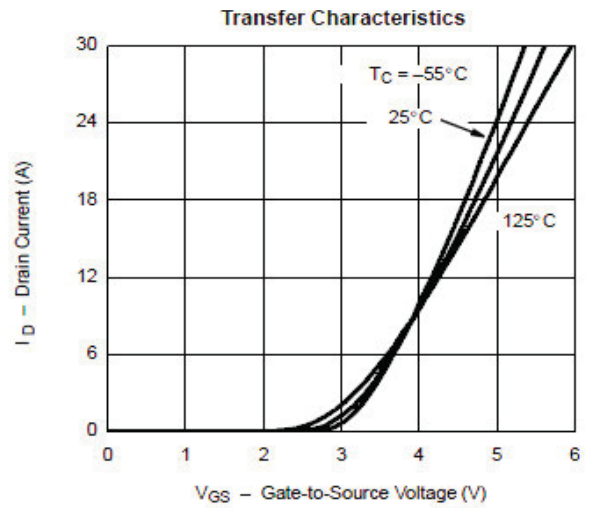
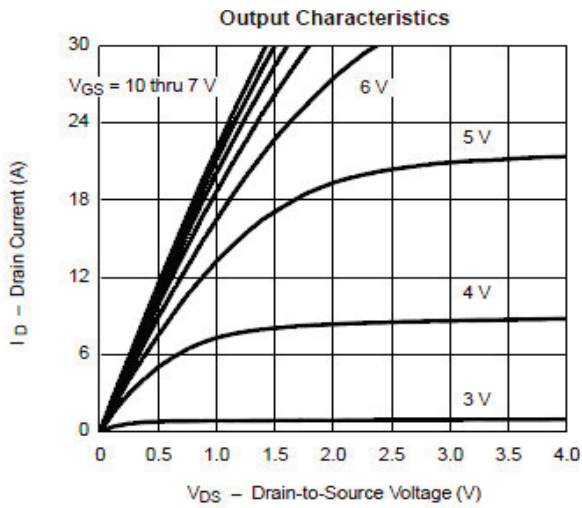

Dual P-channel MOSFET

ELM57923WSA-N

<http://www.elm-tech.com>

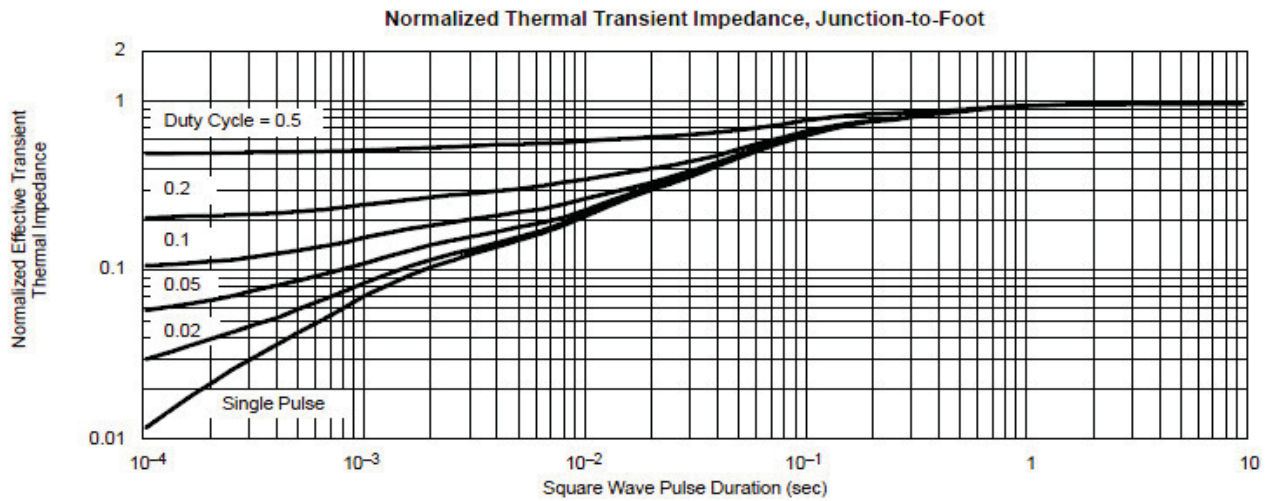
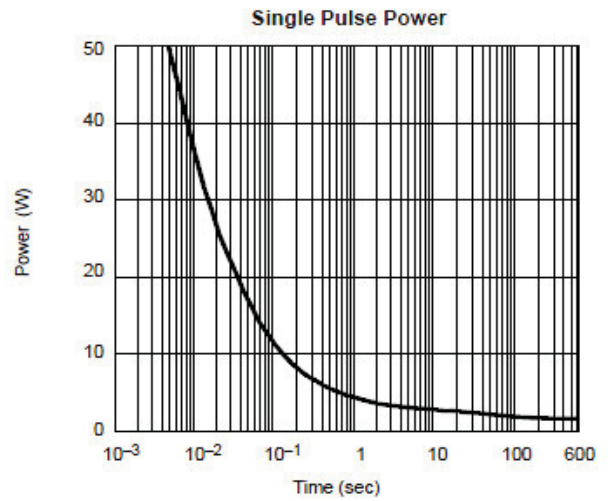
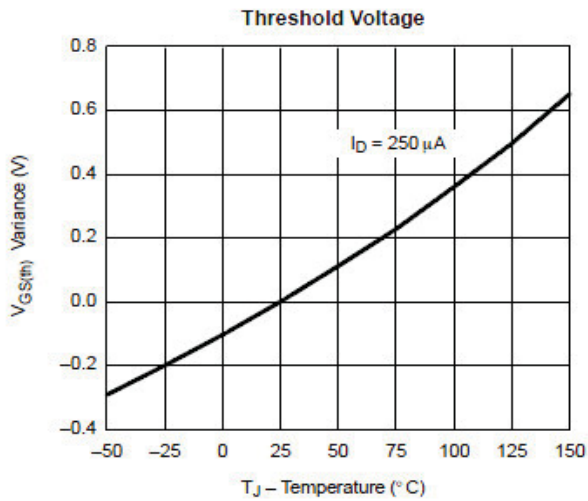
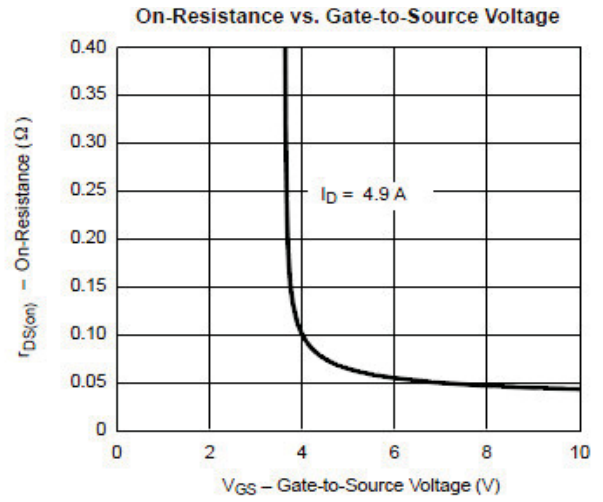
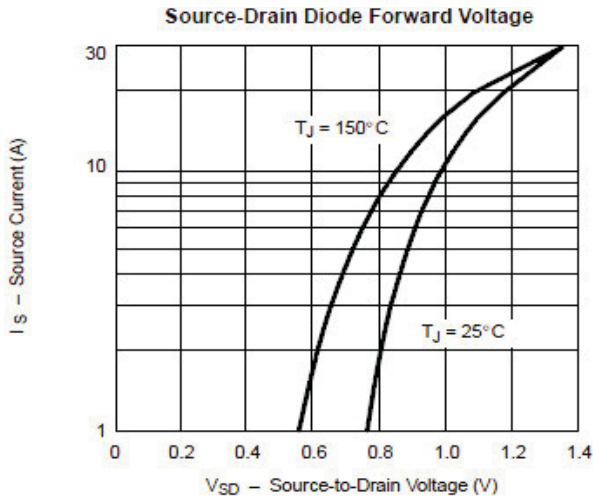

Dual P-channel MOSFET

ELM57923WSA-N

<http://www.elm-tech.com>

■ Test circuit & waveform

Gate Charge Test Circuit & Waveform

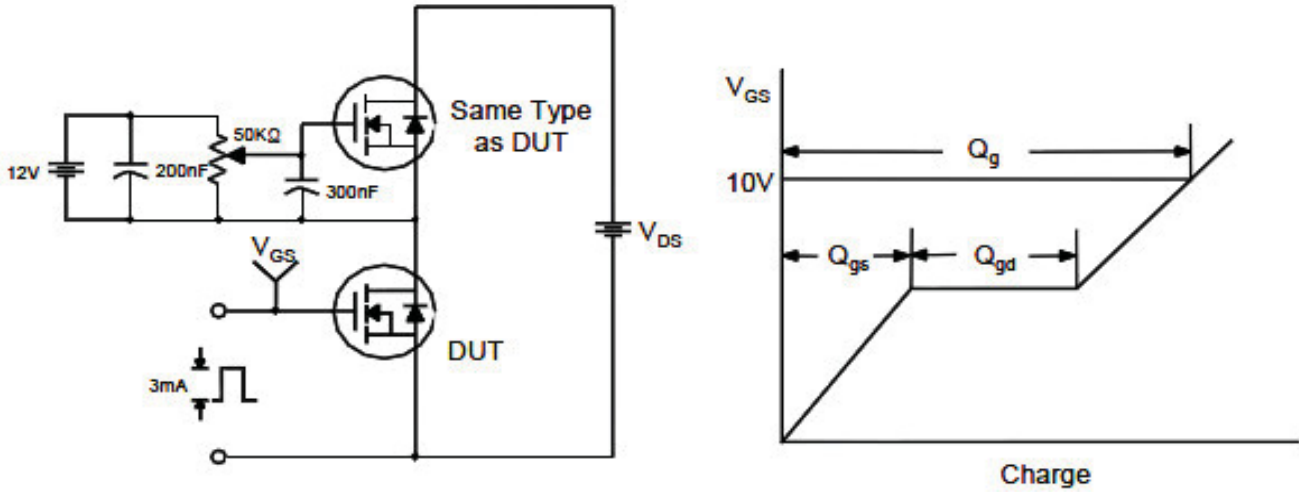

Resistive Switching Test Circuit & Waveforms

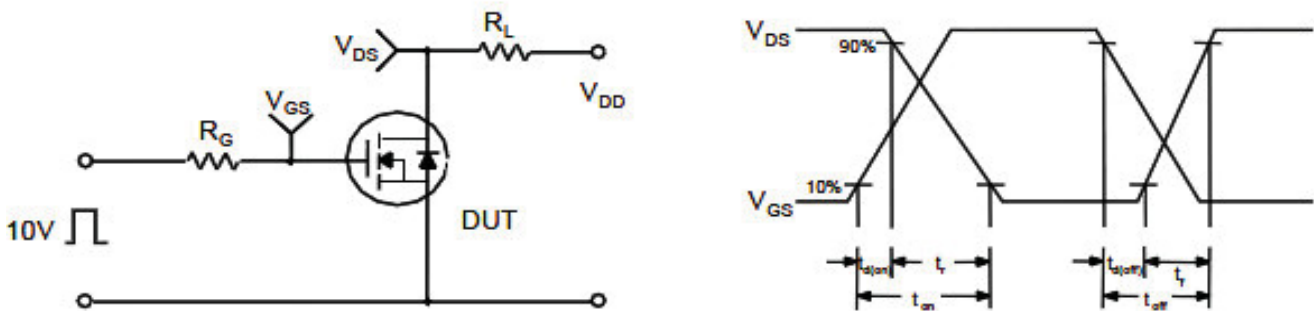

Unclamped Inductive Switching Test Circuit & Waveforms

