

# ELM842B CMOS Operational amplifier

## ■ General description

ELM842B is low voltage and low power CMOS single operational amplifier which makes it easy to design circuits and operates from a 1.2V single power source. As for power supply voltage, ELM recommends to use within the range of 1.2 V to 5.5 V. The consumption current of ELM842B is low; on the other hand, since the output stage of ELM842B is class A operation drive, ELM842B is able to provide current supply of 90 $\mu$ A (Typ. At Vdd=1.5V). ELM842B is suitable for signal process of applications which require low power.

## ■ Features

- Operation from a single power source
- Input available within the range of power supply voltage
- Low voltage operation : 1.2V $\leq$ Vdd $\leq$ 5.5V
- Low current consumption : Typ.130 $\mu$ A(Vdd=1.5V)
- Unity gain bandwidth : Typ.1.0MHz(Vdd=1.5V)
- Package : SOT-25

## ■ Application

- Battery-operated portable devices
- Signal process in low power circuit
- Low voltage analog circuit

## ■ Maximum absolute ratings

Parameter	Symbol	Limit	Unit
Power supply voltage	Vdd	10	V
Input voltage	Vin	Vss-0.3 to Vdd+0.3	V
Differential input voltage	Vid	Vdd-Vss	V
Output voltage	Vout	Vss-0.3 to Vdd+0.3	V
Output short circuit		Continuous	Sec.*
Power dissipation	Pd	300	mW
Operating temperature	Top	-30 to +80	$^{\circ}$ C
Storage temperature	Tstg	-55 to +125	$^{\circ}$ C

\* When power supply voltage is below 5.0V, short of output terminal will do no damage to the IC.  
When power supply voltage is above 5.0V, it may cause short of VDD and result in reliability damage of the IC.

## ■ Suggested operating condition

Parameter	Symbol	Min.	Typ.	Max.	Unit
Power supply voltage	Vdd	1.2		5.5	V
Operating temperature	Top	-20		+70	$^{\circ}$ C

## ■ Selection guide

ELM842B-x

Symbol		
a	Product version	B
b	Taping direction	S, N: Refer to PKG file

ELM842 B - x  
 $\uparrow$   $\uparrow$   
 a b

## ■ Pin configuration

SOT-25(TOP VIEW)

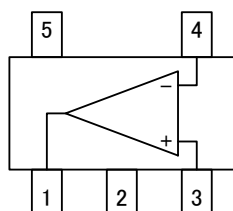

Pin No.	Pin name
1	OUT
2	VDD
3	IN+
4	IN-
5	VSS

## ■ Standard circuit

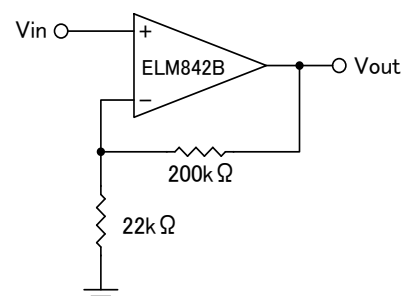

# ELM842B CMOS Operational amplifier

## ■Electrical characteristics

Vdd=1.5V

Vss=0V, Top=25°C

Parameter	Symbol	Condition	Min.	Typ.	Max.	Unit
Input offset voltage	Vio	Vout=Vdd/2			10	mV
Input bias current	Iib				1	nA
Common-mode input voltage range	Vcmr		0.08		1.45	V
Maximum output voltage swing	Vouts	Vid=100mV, RL=200kΩ	1.42			V
Maximum output source current	Isource	Vid=100mV	40	90		μA
Open-loop gain	Avd	Vout=300mV, RL=200kΩ		75		dB
Common-mode rejection ratio	CMRR			75		dB
Supply voltage rejection ratio	PSRR			75		dB
Current consumption	Iss	Vout=Vdd/2, No-load		130	240	μA
Unity gain bandwidth	GBW			1		MHz
Slew rate	SR	RL=200kΩ, CL=20pF	0.45	1.00		V/μs

Vdd=3.0V

Vss=0V, Top=25°C

Parameter	Symbol	Condition	Min.	Typ.	Max.	Unit
Input offset voltage	Vio	Vout=Vdd/2			10	mV
Input bias current	Iib				1	nA
Common-mode input voltage range	Vcmr		0.04		2.90	V
Maximum output voltage swing	Vouts	Vid=100mV, RL=200kΩ	2.80			V
Maximum output source current	Isource	Vid=100mV	45	100		μA
Open-loop gain	Avd	Vout=300mV, RL=200kΩ		80		dB
Common-mode rejection ratio	CMRR			85		dB
Supply voltage rejection ratio	PSRR			80		dB
Current consumption	Iss	Vout=Vdd/2, No-load		145	280	μA
Unity gain bandwidth	GBW			1		MHz
Slew rate	SR	RL=200kΩ, CL=20pF	0.45	1.00		V/μs

## ■Marking

SOT-25

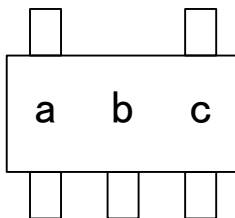

Symbol	Mark	Content
a	C	ELM842B
b	0 to 9	Lot No.
c	0 to 9	Lot No.

# ELM842B CMOS Operational amplifier

## ■Note

### 1) Load resistance

ELM842B is designed for low power consumption applications; hence, the output source current is only 90 $\mu$ A (Typ. at V<sub>dd</sub>=1.5V). As a result, ELM842B is not able to maintain output voltage swing when trying to drive small load resistance. Considering this, load and feedback resistance for ELM842B should be selected carefully.

ELM recommends the following operating temperature range.

< Power supply voltage >	< total resistance value of load/feedback resistor >
V <sub>dd</sub> ≤5.5V	R≥250k $\Omega$
V <sub>dd</sub> ≤3.6V	R≥200k $\Omega$
V <sub>dd</sub> ≤1.8V	R≥150k $\Omega$

### 2) Operation from single power source

ELM842B is designed to be most suitable for single power source; therefore, ELM842B is able to share power supply with logic circuit one. Meanwhile, ELM842B can also operate from double power sources. To protect power supplies of ELM842B and logic circuit from noise, please separate wire from power supply and use decoupling (bypass) capacitor. Using the capacitor can improve PSRR characteristics, especially on 10kHz to 100kHz or more.

### 3) Feedback

When OP-AMP circuit is used with feedback resistor, oscillation may happen in the circuit with loop-gain like unity gain follower.

a) When large feedback resistance is used, the phase margin is decreased by its combination with the parasitic capacitance of the input part of OP-AMP. In this situation, please connect small capacitor parallelly with feedback resistor as shown in fig-1.

b) For capacitive load, external resistor in series connection will be effective as shown in fig-2.

c) Being used as an unity gain follow, ELM842B is able to drive capacitive load of 100pF directly without oscillation.

### 4) Operation at V<sub>dd</sub><1.2V

ELM842B is able to maintain operation when supply voltage is below 1.2V (V<sub>dd</sub>≥1.2V) since all input voltage is acceptable within the range of power supply voltage. However, AC characteristics will become weak under this situation because of the decrease of bias current in the IC. For further information, please contact ELM.

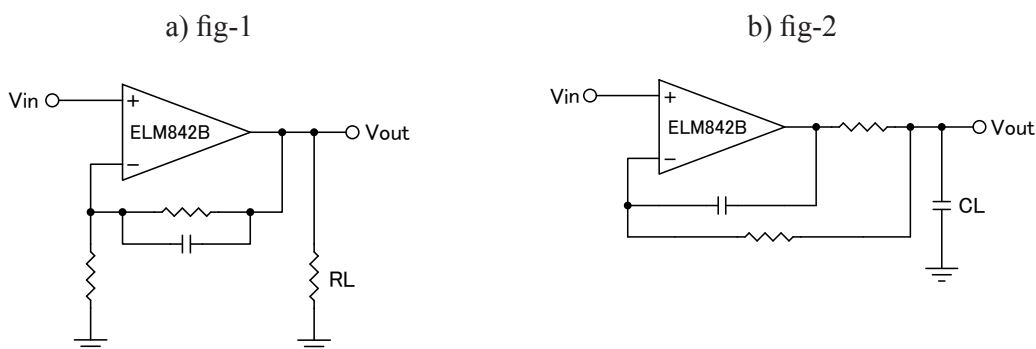

# ELM842B CMOS Operational amplifier

## ■ Typical characteristics

