

# ELM0431BA 2.5V Programmable shunt regulator

http://www.elm-tech.com

## ■ General description

ELM0431BA is three-terminal adjustable shunt regulator utilizing an accurate 2.5V band-gap reference. The output voltage can be set to any value between 2.5V (Vref) to 29V with two external resistors as shown in the typical application circuit. The device exhibit a wide operating current range of 0.4 to 100 mA with a typical dynamic impedance of 0.25Ω. The characteristics of these reference make it excellent replacements for zener diodes in many applications such as digital voltmeters, power supplies, and op amp circuitry. The 2.5V volt reference makes it convenient to obtain a stable reference from 5.0V logic supplies.

ELM0431BA shunt regulator is available in a SOT-23 package.

## ■ Features

- Low cost solution
- Shunt capacity : 100mA
- Output voltage range(adj.) : Set up to 29V
- Output impedance : Typ.0.25Ω
- Trimmed band-gap design : 1%
- Package : SOT-23(ELM0431BA)

## ■ Application

- Linear regulator
- Precision voltage reference
- Switching power supplies
- Battery operating equipment
- Instrumentation

## ■ Maximum absolute ratings

Parameter	Symbol	Limit	Unit
Cathode-Anode reverse breakdown voltage	Vka	30	V
Cathode –Anode current	Ika	100	mA
Reference input current	Iref	10	mA
Power dissipation (Ta=25°C)	Pd	200 (*1)	mW
		500 (*2)	
Junction temperature	Tj	150	°C
Operating temperature (Tj <150°C)	Top	-40 to +125	°C
Storage temperature	Tstg	-65 to +150	°C

\* 1. No mounted, IC alone.

\* 2. When mounted on glass epoxy 2-layers PCB (EIJ/JEDEC standard size: 76.2 mm×114.3 mm×1.6 mm), Cu thickness 35 μm, copper foil area ratio 20% on the front side, back side 100% .

## ■ Selection guide

### ELM0431BA-S

Symbol		
a	Package	B: SOT-23(ELM0431BA)
b	Product version	A
c	Taping direction	S: Refer to PKG file

ELM0431 B A - S  
 ↑ ↑ ↑  
 a b c

\* Taping direction is one way.

# ELM0431BA 2.5V Programmable shunt regulator

<http://www.elm-tech.com>

## ■ Pin configuration

(TOP VIEW)

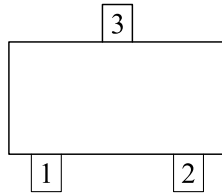

Pin No.	Pin name
1	REFERENCE
2	CATHODE
3	ANODE

## ■ Circuit

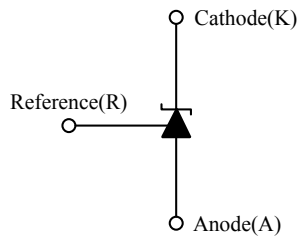

## ■ Typical application

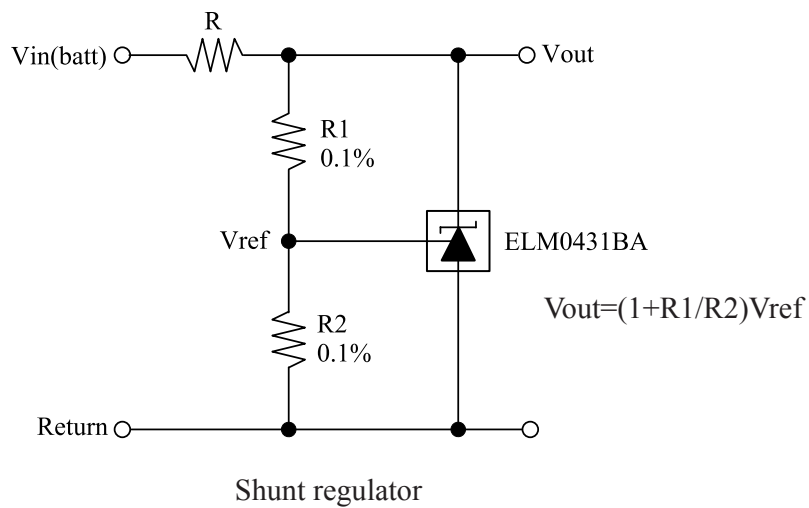

## ■ Block diagram

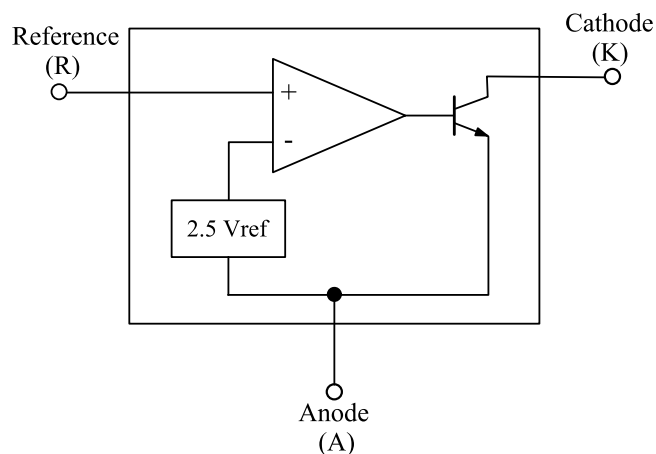

# ELM0431BA 2.5V Programmable shunt regulator

<http://www.elm-tech.com>

## ■Electrical characteristics

$V_{ka}=V_{ref}$ ,  $I_k=10mA$ ,  $T_{op}=25^{\circ}C$ , unless otherwise stated

Parameter	Symbol	Condition	Min.	Typ.	Max.	Unit	Note
Reference voltage	$V_{ref}$		2.470	2.495	2.520	V	1
Reference voltage with temperature	$\Delta V_{ref}/\Delta T_{op}$			0.07	0.20	mV/ $^{\circ}C$	1
Ration of change in $V_{ref}$ to cathode voltage	$V_{ref}/V_{in}$	$V_{ref}$ to 10V	-2.7	-1.0		mV/V	2
		10V to 30V	-2.0	-0.4	0.3		
Reference input current	$I_{ref}$			0.7	4.0	$\mu A$	2
$I_{ref}$ temperature deviation	$\Delta I_{ref}$	$T_a=-20$ to $85^{\circ}C$		0.4	1.2	$\mu A$	2
Min. $I_k$ for regulation	$I_k(\min)$			0.4	1.0	mA	1
Stand-by current	$I_{standby}$	$V_{ref}=0V$ , $V_{ka}=30V$		0.1	1.0	$\mu A$	3
Dynamic output impedance	$Z_{out}$	$f \leq 1kHz$ , $I_k=1$ to $100mA$		0.25	0.50	$\Omega$	1

Note : test circuit No.

## ■Test circuits

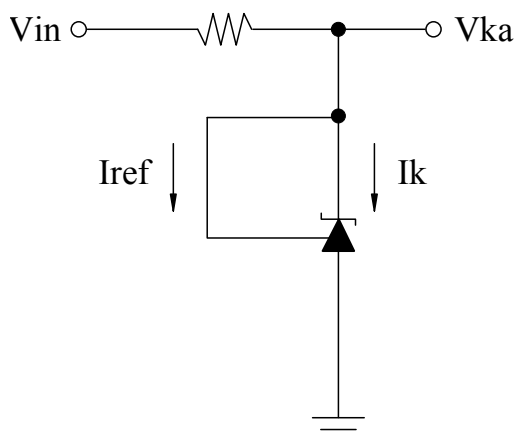

Test circuit 1 :  $V_{ka}=V_{ref}$

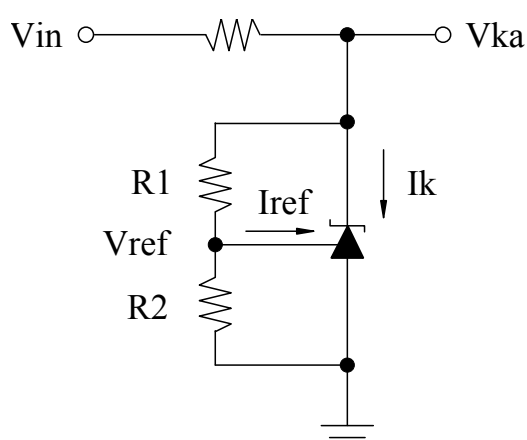

Test circuit 2 :  $V_{ka}>V_{ref}$

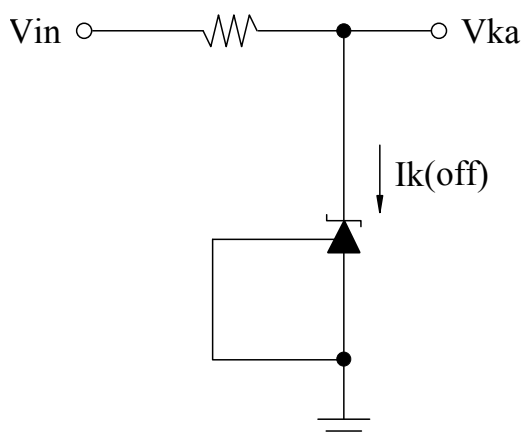

Test circuit 3 : Off state current

# ELM0431BA 2.5V Programmable shunt regulator

<http://www.elm-tech.com>

## ■ Typical characteristics

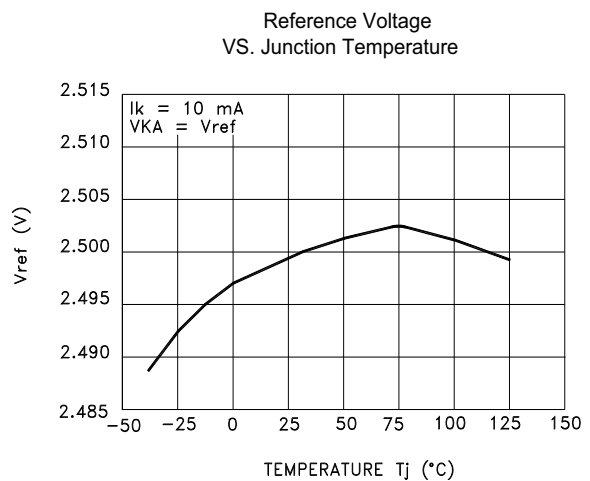
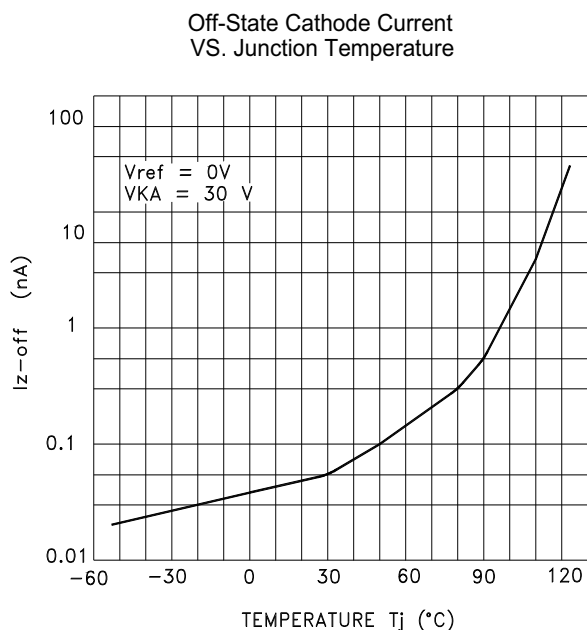
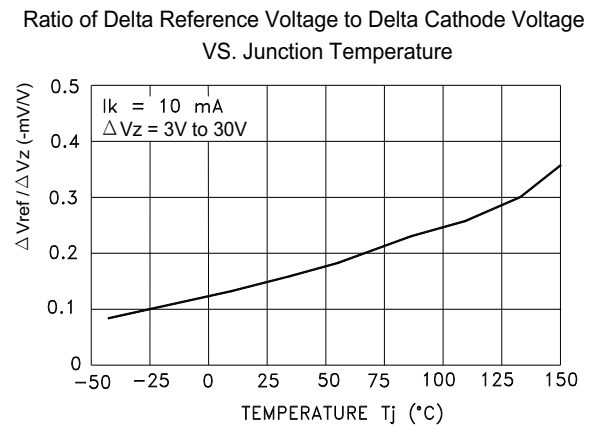
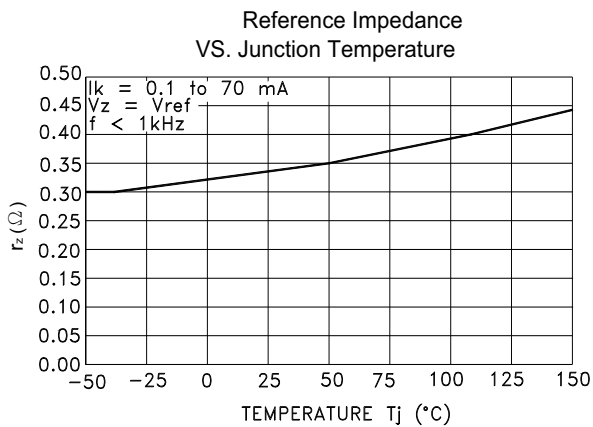
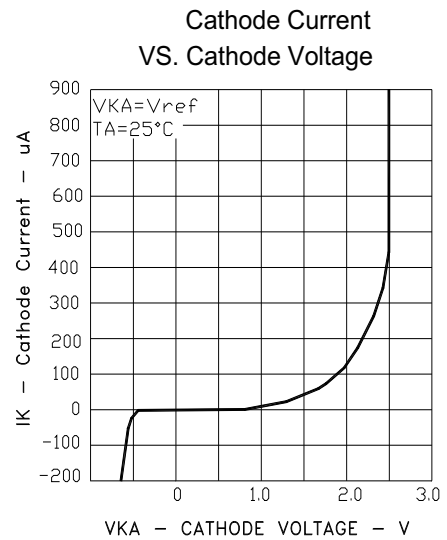
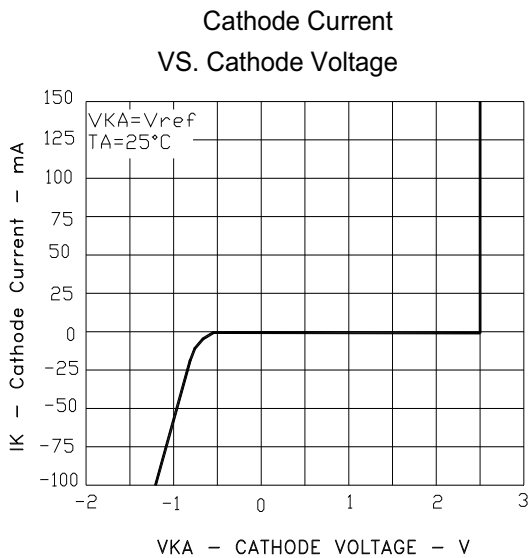

# ELM0431BA 2.5V Programmable shunt regulator

<http://www.elm-tech.com>

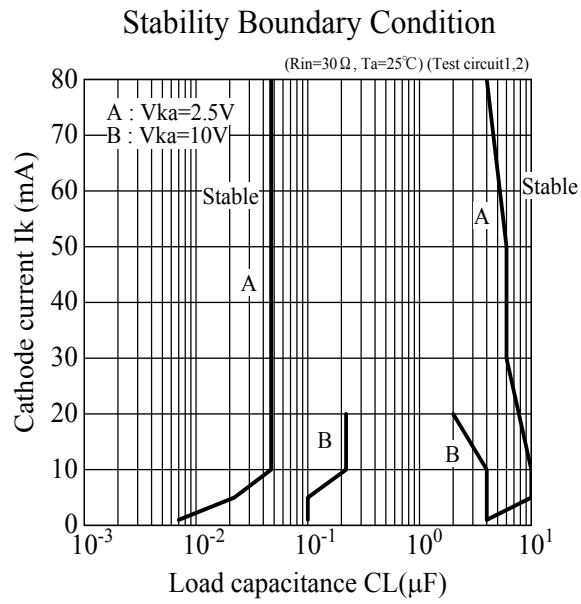

## ■ Marking

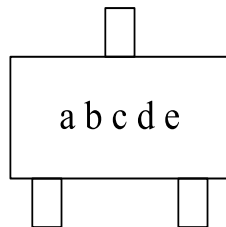

a to e : Assembly lot No. —  
A to Z (I, O, X excepted) and 0 to 9