

# ELM87xxxxA 1μA Low power consumption CMOS 300mA V/R

<https://www.elm-tech.com>

## ■General description

ELM87xxxxA is CMOS voltage regulator which is characterized with low current consumption and low dropout. ELM87 series provides high output current of 300mA while the consumption current is comparatively low, which is Typ.1.0μA. There are 2 types of CE selection for ELM87 series: non-chip enable function and “H” active. The standard output voltages are 1.8V, 2.5V, 3.0V, 3.3V, 5.0V; ELM87 series can also be designed as a semi-custom IC within the range of 1.5V to 5.0V by 0.1V step. Thermal shutdown protection and short-circuit current limiter are included in the IC. Ceramic condenser with low ESR can be used as input and output ones.

## ■Features

- Output voltage range : 1.5V to 5.0V (by 0.1V)
- Output current : Min.200mA(1.5V to 3.9V)  
Min.300mA(4.0V to 5.0V)
- Current consumption : Typ.1.0μA
- Standby current consumption : Typ.0.1μA
- Input stability : Typ.0.05%/V
- Load stability : Typ.10mV(1mA≤Iout≤100mA)
- Accuracy of output voltage : ±2.0%
- Input-output voltage difference : Typ.125mV(Vout=3.0V, Iout=100mA)
- Short circuit current limiter : Typ.50mA(Vout=0V)
- Thermal shutdown protection : Typ.160°C
- Chip enable pin : “H” active (ELM87xx3xA)
- Package : SOT-89, SOT-89-5, SOT-23, SOT-25  
SC-70-5(SOT-353)

## ■Application

- Cell phones
- Battery operated devices
- Wireless devices
- Portable AV equipments

## ■Maximum absolute ratings

Parameter	Symbol	Limit	Unit			
Input voltage	Vin	Vss-0.3 to 7.0	V			
CE Input voltage	Vce	Vss-0.3 to Vin+0.3	V			
Output voltage	Vout	Vss-0.3 to Vin+0.3	V			
Output current	Iout	600	mA			
Power dissipation (Ta=25°C)	Pd	SOT-89	500 <sup>(*1)</sup>	SOT-25	250 <sup>(*1)</sup>	mW
			1000 <sup>(*2)</sup>		600 <sup>(*2)</sup>	
		SOT-89-5	500 <sup>(*1)</sup>	SC-70-5 (SOT-353)	150 <sup>(*1)</sup>	
			1000 <sup>(*2)</sup>		400 <sup>(*2)</sup>	
		SOT-23	250 <sup>(*1)</sup>			
			500 <sup>(*2)</sup>			
Operationg Temperature	Top	-40 to +85	°C			
Storage Temperature	Tstg	-55 to +125	°C			

\* 1. No mounted, IC alone.

\* 2. When mounted on glass epoxy 2-layers PCB (EIJ/JEDEC standard size: 76.2 mm×114.3 mm×1.6 mm), Cu thickness 35 μm, copper foil area ratio 20% on the front side, back side 100% .

# ELM87xxxxA 1μA Low power consumption CMOS 300mA V/R

<https://www.elm-tech.com>

## ■ Selection guide

ELM87xxxA-x, ELM87xx3xA-x

Symbol		
a, b	Output voltage	e.g. : 18: Vout=1.8V    25: Vout=2.5V 30: Vout=3.0V    33: Vout=3.3V 50: Vout=5.0V
c	CE selection	NONE: No CE 3: CE="H"active
d	Package	A: SOT-89, SOT-89-5 B: SOT-23, SOT-25 C: SC-70-5(SOT-353)
e	Product version	A
f	Taping direction	S, N: Refer to PKG file

- No CE

ELM87 x x x A - x  
 ↑ ↑ ↑ ↑ ↑  
 a b d e f

- CE="H"active

ELM87 x x 3 x A - x  
 ↑ ↑ ↑ ↑ ↑ ↑  
 a b c d e f

## ■ Pin configuration

SOT-89(TOP VIEW)

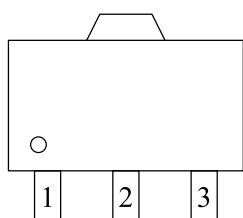

ELM87xxAA

Pin No.	Pin name
1	VSS
2	VIN
3	VOUT

SOT-89-5(TOP VIEW)

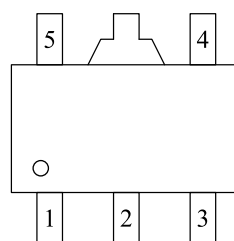

ELM87xx3AA

Pin No.	Pin name
1	VSS
2	VIN
3	VOUT
4	NC
5	CE

SOT-23(TOP VIEW)

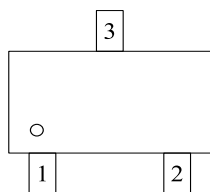

ELM87xxBA

Pin No.	Pin name
1	VSS
2	VOUT
3	VIN

SOT-25(TOP VIEW)

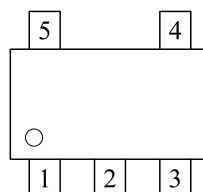

ELM87xx3BA

Pin No.	Pin name
1	VSS
2	VIN
3	VOUT
4	NC
5	CE

SC-70-5(TOP VIEW)

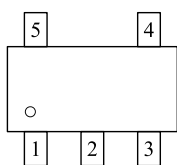

ELM87xxCA

Pin No.	Pin name
1	NC
2	VIN
3	NC
4	VSS
5	VOUT

SC-70-5(TOP VIEW)

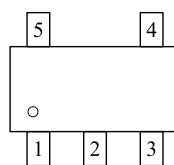

ELM87xx3CA

Pin No.	Pin name
1	VSS
2	VIN
3	VOUT
4	NC
5	CE

# ELM87xxxxA 1μA Low power consumption CMOS 300mA V/R

<https://www.elm-tech.com>

## ■Standard circuit

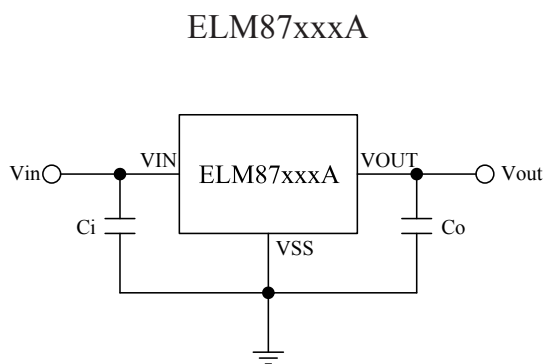

\* Ci=1μF, Co=1μF or greater

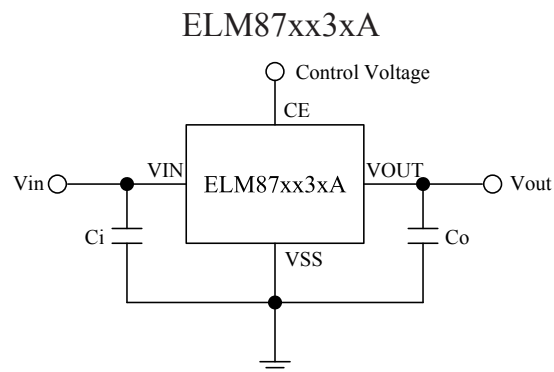

\* Ci=1μF, Co=1μF or greater

## ■Block diagram

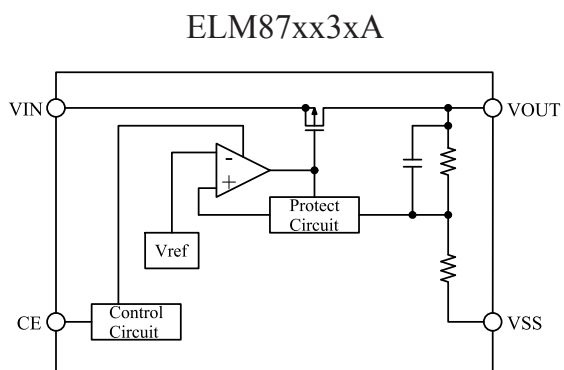
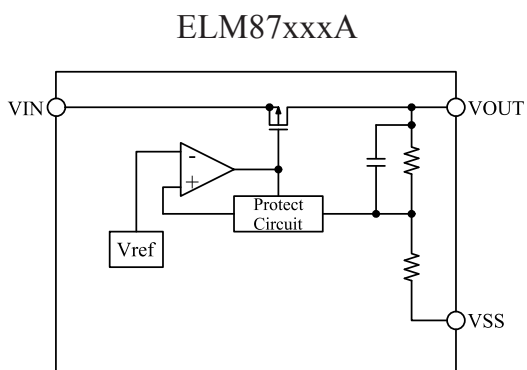

## ■Electrical characteristics (ELM87xxxA, No CE pin)

Vout=1.8V(ELM8718xA), No CE pin

Ci=1.0μF, Co=1.0μF, Top=25°C

Parameter	Symbol	Condition	Min.	Typ.	Max.	Unit
Output voltage	Vout	Vin=2.8V, Iout=40mA	1.764	1.800	1.836	V
Output current	Iout	Vin=2.8V	200			mA
Input stability	$\Delta V_{out}/\Delta V_{in}$	Iout=40mA, 2.3V ≤ Vin ≤ 6.0V		0.05	0.25	%/V
Load stability	$\Delta V_{out}/\Delta I_{out}$	1mA ≤ Iout ≤ 100mA, Vin=2.8V		10	20	mV
Input-Output voltage differential	Vdif	Iout=100mA		180	280	mV
Current consumption	Iss	Vin=2.8V, No-load		1.0	3.0	μA
Input voltage	Vin		1.8		6.0	V
Short circuit current	Ilim	Vout=0V		50		mA
Thermal shutdown temperature	Tsd			160		°C

# ELM87xxxxA 1 $\mu$ A Low power consumption CMOS 300mA V/R

<https://www.elm-tech.com>

Vout=2.5V(ELM8725xA), No CE pin

Ci=1.0 $\mu$ F, Co=1.0 $\mu$ F, Top=25°C

Parameter	Symbol	Condition	Min.	Typ.	Max.	Unit
Output voltage	Vout	Vin=3.5V, Iout=40mA	2.450	2.500	2.550	V
Output current	Iout	Vin=3.5V	200			mA
Input stability	$\Delta$ Vout/ $\Delta$ Vin	Iout=40mA, 3.0V $\leq$ Vin $\leq$ 6.0V		0.05	0.25	%/V
Load stability	$\Delta$ Vout/ $\Delta$ Iout	1mA $\leq$ Iout $\leq$ 100mA, Vin=3.5V		10	20	mV
Input-Output voltage differential	Vdif	Iout=100mA		150	220	mV
Current consumption	Iss	Vin=3.5V, No-load		1.0	3.0	$\mu$ A
Input voltage	Vin		1.8		6.0	V
Short circuit current	Ilim	Vout=0V		50		mA
Thermal shutdown temperature	Tsd			160		°C

Vout=3.0V(ELM8730xA), No CE pin

Ci=1.0 $\mu$ F, Co=1.0 $\mu$ F, Top=25°C

Parameter	Symbol	Condition	Min.	Typ.	Max.	Unit
Output voltage	Vout	Vin=4.0V, Iout=40mA	2.940	3.000	3.060	V
Output current	Iout	Vin=4.0V	200			mA
Input stability	$\Delta$ Vout/ $\Delta$ Vin	Iout=40mA, 3.5V $\leq$ Vin $\leq$ 6.0V		0.05	0.25	%/V
Load stability	$\Delta$ Vout/ $\Delta$ Iout	1mA $\leq$ Iout $\leq$ 100mA, Vin=4.0V		10	20	mV
Input-Output voltage differential	Vdif	Iout=100mA		125	190	mV
Current consumption	Iss	Vin=4.0V, No-load		1.0	3.0	$\mu$ A
Input voltage	Vin		1.8		6.0	V
Short circuit current	Ilim	Vout=0V		50		mA
Thermal shutdown temperature	Tsd			160		°C

Vout=3.3V(ELM8733xA), No CE pin

Ci=1.0 $\mu$ F, Co=1.0 $\mu$ F, Top=25°C

Parameter	Symbol	Condition	Min.	Typ.	Max.	Unit
Output voltage	Vout	Vin=4.3V, Iout=40mA	3.234	3.300	3.366	V
Output current	Iout	Vin=4.3V	200			mA
Input stability	$\Delta$ Vout/ $\Delta$ Vin	Iout=40mA, 3.8V $\leq$ Vin $\leq$ 6.0V		0.05	0.25	%/V
Load stability	$\Delta$ Vout/ $\Delta$ Iout	1mA $\leq$ Iout $\leq$ 100mA, Vin=4.3V		10	20	mV
Input-Output voltage differential	Vdif	Iout=100mA		125	190	mV
Current consumption	Iss	Vin=4.3V, No-load		1.0	3.0	$\mu$ A
Input voltage	Vin		1.8		6.0	V
Short circuit current	Ilim	Vout=0V		50		mA
Thermal shutdown temperature	Tsd			160		°C

# ELM87xxxxA 1 $\mu$ A Low power consumption CMOS 300mA V/R

<https://www.elm-tech.com>

Vout=5.0V(ELM8750xA), No CE pin

Ci=1.0 $\mu$ F, Co=1.0 $\mu$ F, Top=25 $^{\circ}$ C

Parameter	Symbol	Condition	Min.	Typ.	Max.	Unit
Output voltage	Vout	Vin=6.0V, Iout=40mA	4.900	5.000	5.100	V
Output current	Iout	Vin=6.0V	300			mA
Input stability	$\Delta$ Vout/ $\Delta$ Vin	Iout=40mA, 5.5V $\leq$ Vin $\leq$ 6.0V		0.05	0.25	%/V
Load stability	$\Delta$ Vout/ $\Delta$ Iout	1mA $\leq$ Iout $\leq$ 100mA, Vin=6.0V		10	20	mV
Input-Output voltage differential	Vdif	Iout=100mA		110	170	mV
Current consumption	Iss	Vin=6.0V, No-load		1.0	3.0	$\mu$ A
Input voltage	Vin		1.8		6.0	V
Short circuit current	Ilim	Vout=0V		50		mA
Thermal shutdown temperature	Tsd			160		$^{\circ}$ C

## ■Electrical characteristics (ELM87xx3xA, CE="H"active)

Vout=1.8V(ELM87183xA), CE="H"active

Ci=1.0 $\mu$ F, Co=1.0 $\mu$ F, Top=25 $^{\circ}$ C

Parameter	Symbol	Condition	Min.	Typ.	Max.	Unit
Output voltage	Vout	Vin=2.8V, Iout=40mA	1.764	1.800	1.836	V
Output current	Iout	Vin=2.8V	200			mA
Input stability	$\Delta$ Vout/ $\Delta$ Vin	Iout=40mA, 2.3V $\leq$ Vin $\leq$ 6.0V		0.05	0.25	%/V
Load stability	$\Delta$ Vout/ $\Delta$ Iout	1mA $\leq$ Iout $\leq$ 100mA, Vin=2.8V		10	20	mV
Input-Output voltage differential	Vdif	Iout=100mA		180	280	mV
Current consumption	Iss	Vin=2.8V, No-load		1.0	3.0	$\mu$ A
Input voltage	Vin		1.8		6.0	V
CE input voltage High	Vceh	Vin=6.0V	1.8		Vin	V
CE input voltage Low	Vcel	Vin=1.8V	0.0		0.2	V
CE input current High	Iceh	Vce=Vin=6.0V	-0.2	0.0	0.2	$\mu$ A
CE input current Low	Icel	Vce=Vss, Vin=6.0V	-0.2	0.0	0.2	
Short circuit current	Ilim	Vout=0V		50		mA
Thermal shutdown temperature	Tsd			160		$^{\circ}$ C

# ELM87xxxxA 1 $\mu$ A Low power consumption CMOS 300mA V/R

<https://www.elm-tech.com>

Vout=2.5V(ELM87253xA), CE="H" active

Ci=1.0 $\mu$ F, Co=1.0 $\mu$ F, Top=25°C

Parameter	Symbol	Condition	Min.	Typ.	Max.	Unit
Output voltage	Vout	Vin=3.5V, Iout=40mA	2.450	2.500	2.550	V
Output current	Iout	Vin=3.5V	200			mA
Input stability	$\Delta V_{out}/\Delta V_{in}$	Iout=40mA, 3.0V $\leq$ Vin $\leq$ 6.0V		0.05	0.25	%/V
Load stability	$\Delta V_{out}/\Delta I_{out}$	1mA $\leq$ Iout $\leq$ 100mA, Vin=3.5V		10	20	mV
Input-Output voltage differential	Vdif	Iout=100mA		150	220	mV
Current consumption	Iss	Vin=3.5V, No-load		1.0	3.0	$\mu$ A
Input voltage	Vin		1.8		6.0	V
CE input voltage High	Vceh	Vin=6.0V	1.8		Vin	V
CE input voltage Low	Vcel	Vin=1.8V	0.0		0.2	V
CE input current High	Iceh	Vce=Vin=6.0V	-0.2	0.0	0.2	$\mu$ A
CE input current Low	Icel	Vce=Vss, Vin=6.0V	-0.2	0.0	0.2	
Short circuit current	Ilim	Vout=0V		50		mA
Thermal shutdown temperature	Tsd			160		°C

Vout=3.0V(ELM87303xA), CE="H" active

Ci=1.0 $\mu$ F, Co=1.0 $\mu$ F, Top=25°C

Parameter	Symbol	Condition	Min.	Typ.	Max.	Unit
Output voltage	Vout	Vin=4.0V, Iout=40mA	2.940	3.000	3.060	V
Output current	Iout	Vin=4.0V	200			mA
Input stability	$\Delta V_{out}/\Delta V_{in}$	Iout=40mA, 3.5V $\leq$ Vin $\leq$ 6.0V		0.05	0.25	%/V
Load stability	$\Delta V_{out}/\Delta I_{out}$	1mA $\leq$ Iout $\leq$ 100mA, Vin=4.0V		10	20	mV
Input-Output voltage differential	Vdif	Iout=100mA		125	190	mV
Current consumption	Iss	Vin=4.0V, No-load		1.0	3.0	$\mu$ A
Input voltage	Vin		1.8		6.0	V
CE input voltage High	Vceh	Vin=6.0V	1.8		Vin	V
CE input voltage Low	Vcel	Vin=1.8V	0.0		0.2	V
CE input current High	Iceh	Vce=Vin=6.0V	-0.2	0.0	0.2	$\mu$ A
CE input current Low	Icel	Vce=Vss, Vin=6.0V	-0.2	0.0	0.2	
Short circuit current	Ilim	Vout=0V		50		mA
Thermal shutdown temperature	Tsd			160		°C

# ELM87xxxxA 1 $\mu$ A Low power consumption CMOS 300mA V/R

<https://www.elm-tech.com>

Vout=3.3V(ELM87333xA), CE="H" active

Ci=1.0 $\mu$ F, Co=1.0 $\mu$ F, Top=25 $^{\circ}$ C

Parameter	Symbol	Condition	Min.	Typ.	Max.	Unit
Output voltage	Vout	Vin=4.3V, Iout=40mA	3.234	3.300	3.366	V
Output current	Iout	Vin=4.3V	200			mA
Input stability	$\Delta$ Vout/ $\Delta$ Vin	Iout=40mA, 3.8V $\leq$ Vin $\leq$ 6.0V		0.05	0.25	%/V
Load stability	$\Delta$ Vout/ $\Delta$ Iout	1mA $\leq$ Iout $\leq$ 100mA, Vin=4.3V		10	20	mV
Input-Output voltage differential	Vdif	Iout=100mA		125	190	mV
Current consumption	Iss	Vin=4.3V, No-load		1.0	3.0	$\mu$ A
Input voltage	Vin		1.8		6.0	V
CE input voltage High	Vceh	Vin=6.0V	1.8		Vin	V
CE input voltage Low	Vcel	Vin=1.8V	0.0		0.2	V
CE input current High	Iceh	Vce=Vin=6.0V	-0.2	0.0	0.2	$\mu$ A
CE input current Low	Icel	Vce=Vss, Vin=6.0V	-0.2	0.0	0.2	
Short circuit current	Ilim	Vout=0V		50		mA
Thermal shutdown temperature	Tsd			160		$^{\circ}$ C

Vout=5.0V(ELM87503xA), CE="H" active

Ci=1.0 $\mu$ F, Co=1.0 $\mu$ F, Top=25 $^{\circ}$ C

Parameter	Symbol	Condition	Min.	Typ.	Max.	Unit
Output voltage	Vout	Vin=6.0V, Iout=40mA	4.900	5.000	5.100	V
Output current	Iout	Vin=6.0V	300			mA
Input stability	$\Delta$ Vout/ $\Delta$ Vin	Iout=40mA, 5.5V $\leq$ Vin $\leq$ 6.0V		0.05	0.25	%/V
Load stability	$\Delta$ Vout/ $\Delta$ Iout	1mA $\leq$ Iout $\leq$ 100mA, Vin=6.0V		10	20	mV
Input-Output voltage differential	Vdif	Iout=100mA		110	170	mV
Current consumption	Iss	Vin=6.0V, No-load		1.0	3.0	$\mu$ A
Input voltage	Vin		1.8		6.0	V
CE input voltage High	Vceh	Vin=6.0V	1.8		Vin	V
CE input voltage Low	Vcel	Vin=1.8V	0.0		0.2	V
CE input current High	Iceh	Vce=Vin=6.0V	-0.2	0.0	0.2	$\mu$ A
CE input current Low	Icel	Vce=Vss, Vin=6.0V	-0.2	0.0	0.2	
Short circuit current	Ilim	Vout=0V		50		mA
Thermal shutdown temperature	Tsd			160		$^{\circ}$ C

# ELM87xxxxA 1 $\mu$ A Low power consumption CMOS 300mA V/R

<https://www.elm-tech.com>

## ■ Marking

- SOT-89, SOT-23 package : ELM87xxxA (No CE)
- SOT-89-5, SOT-25 package : ELM87xx3xA (with CE)

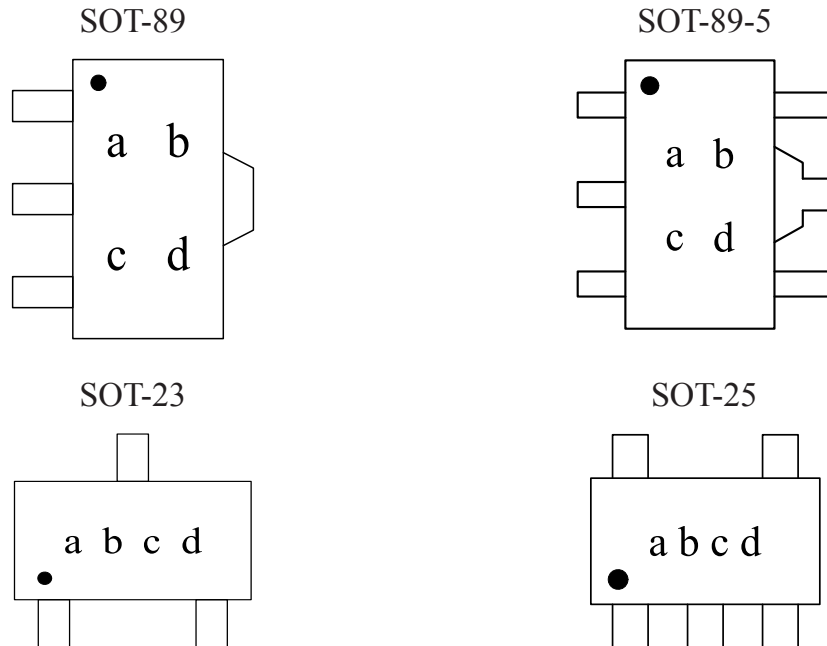

a to d : Assembly lot No. ——  
A to Z (I, O, X excepted) and 0 to 9

- SC-70-5 package : ELM87xxCA (No CE)  
ELM87xxx3CA (with CE)

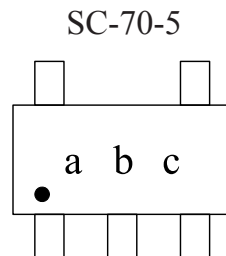

a to c : Assembly lot No. ——  
A to Z (I, O, X excepted) and 0 to 9



# ELM87xxxxA 1 $\mu$ A Low power consumption CMOS 300mA V/R

<https://www.elm-tech.com>

## ■ Typical characteristics

- 1.8V Vout unit (ELM8718xA, ELM87183xA) Ci=1.0 $\mu$ F, Co=1.0 $\mu$ F, Top=25 $^{\circ}$ C

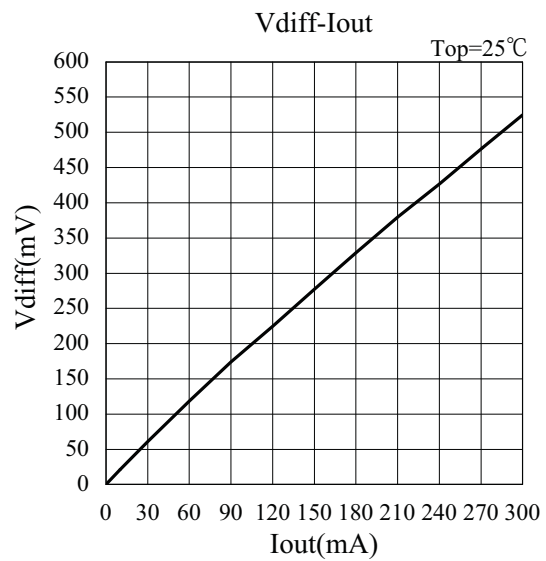
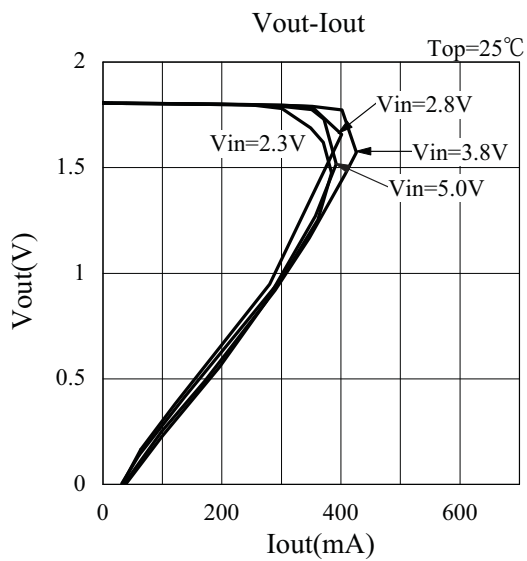
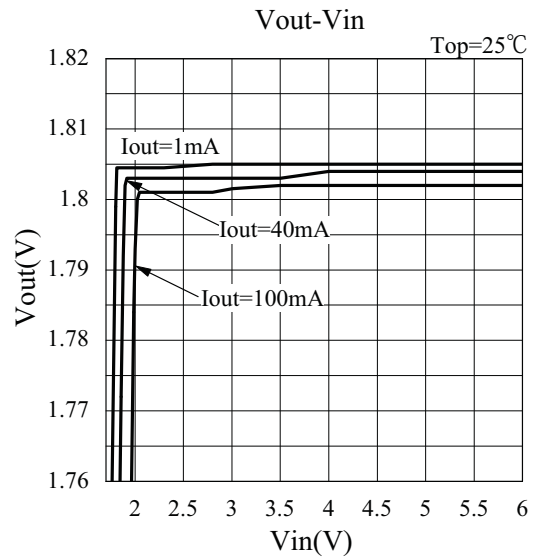
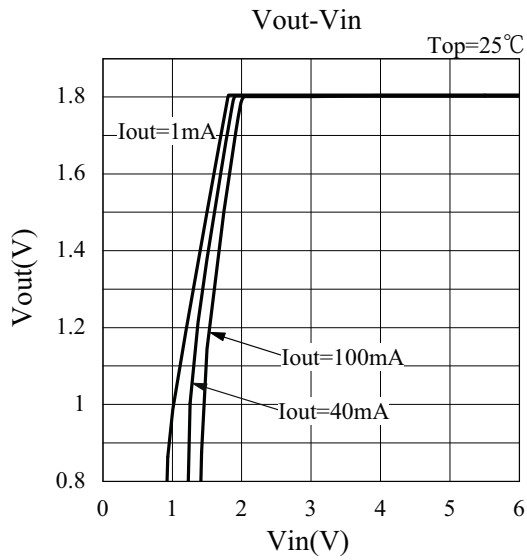

# ELM87xxxxA 1 $\mu$ A Low power consumption CMOS 300mA V/R

<https://www.elm-tech.com>

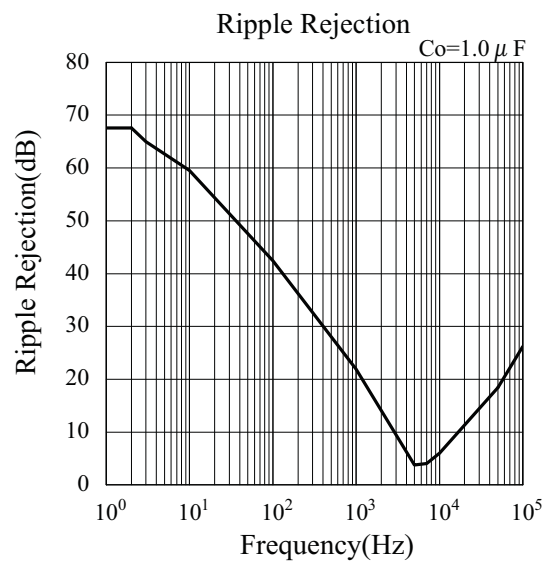
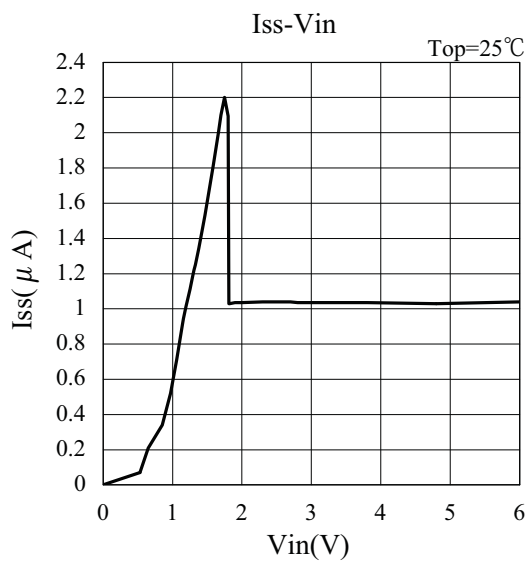
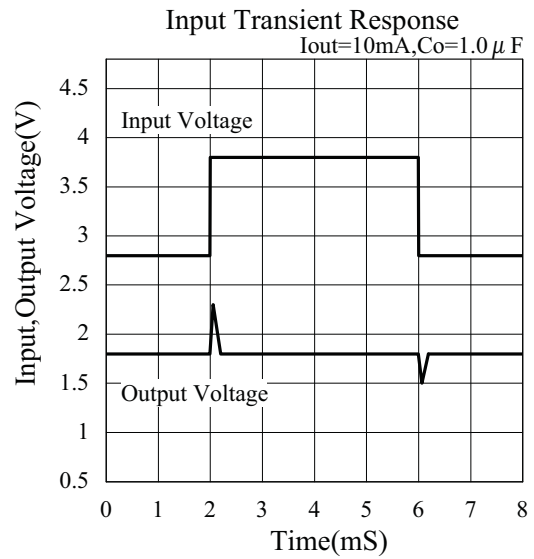
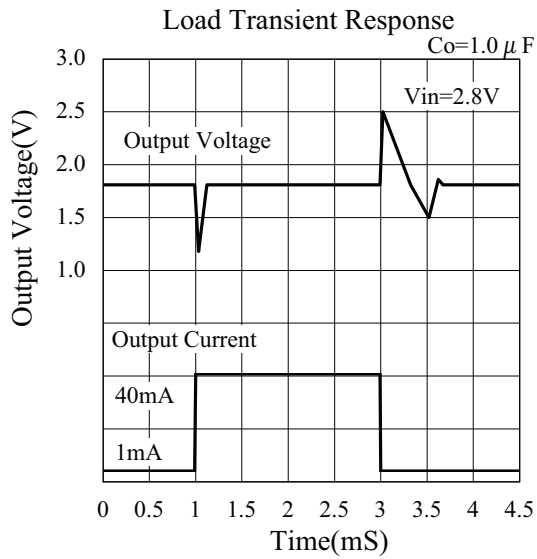

# ELM87xxxxA 1 $\mu$ A Low power consumption CMOS 300mA V/R

<https://www.elm-tech.com>

- 2.5V Vout unit (ELM8725xA, ELM87253xA) Ci=1.0 $\mu$ F, Co=1.0 $\mu$ F, Top=25°C

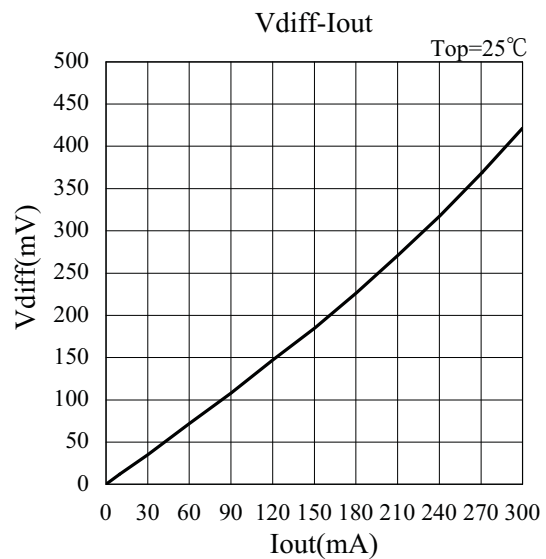
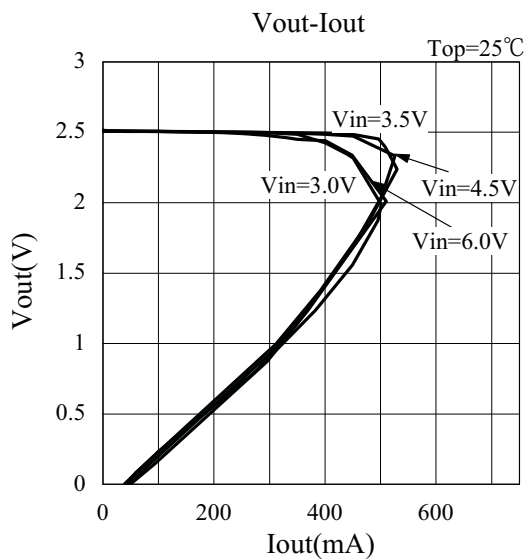
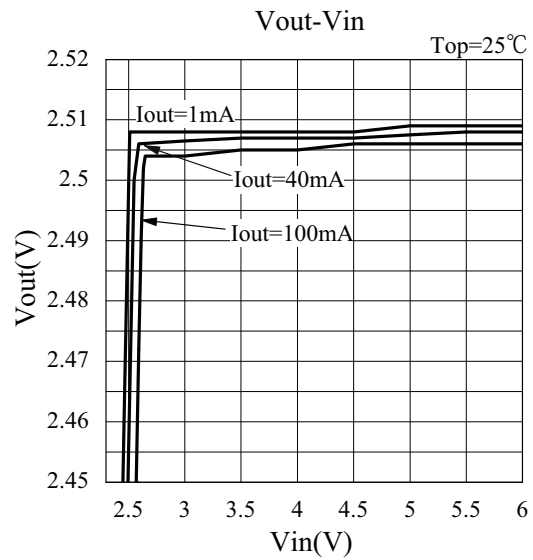
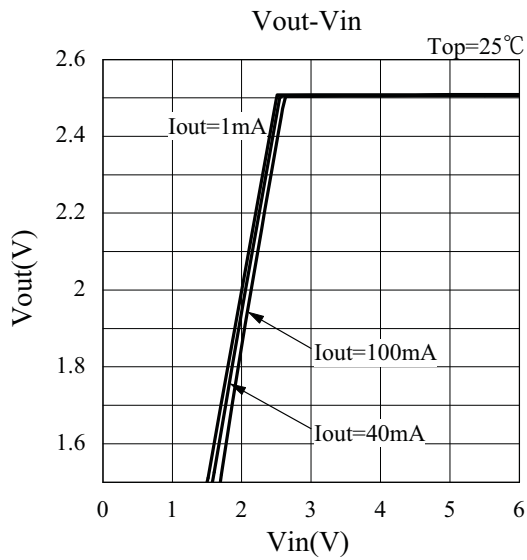

# ELM87xxxxA 1 $\mu$ A Low power consumption CMOS 300mA V/R

<https://www.elm-tech.com>

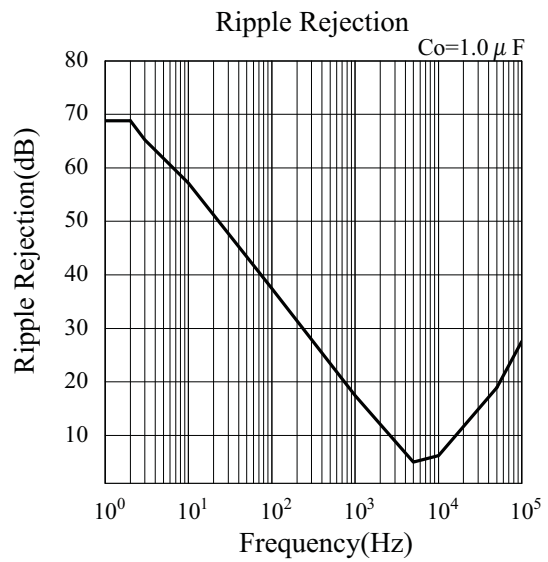
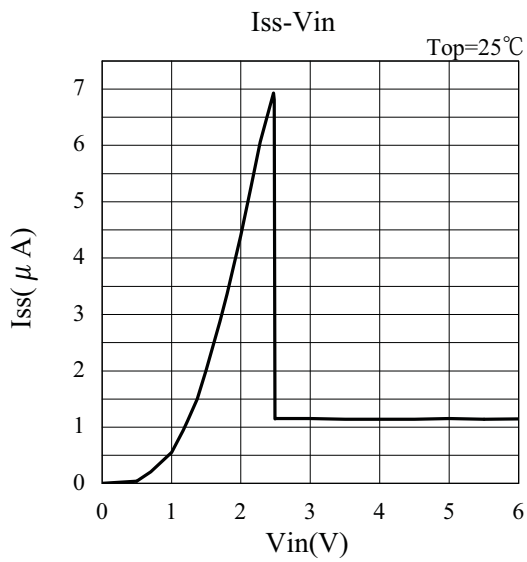
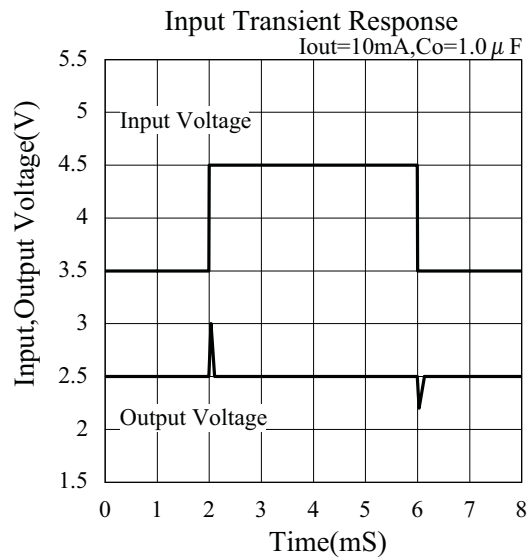
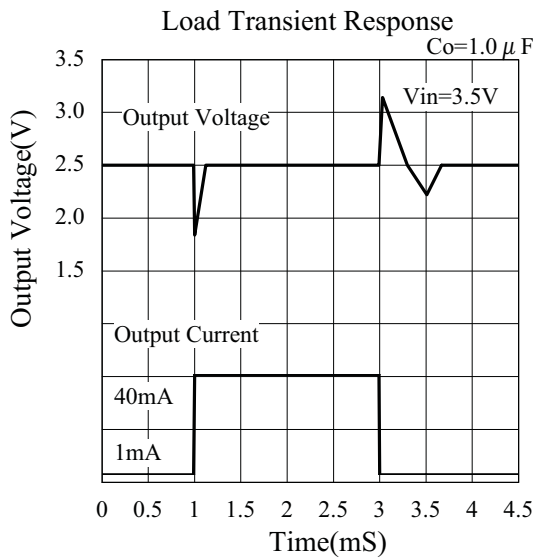

# ELM87xxxxA 1 $\mu$ A Low power consumption CMOS 300mA V/R

<https://www.elm-tech.com>

- 3.0V Vout unit (ELM8730xA, ELM87303xA) Ci=1.0 $\mu$ F, Co=1.0 $\mu$ F, Top=25 $^{\circ}$ C

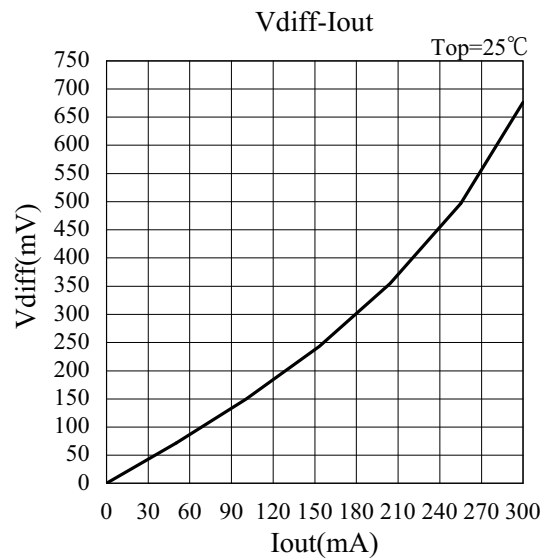
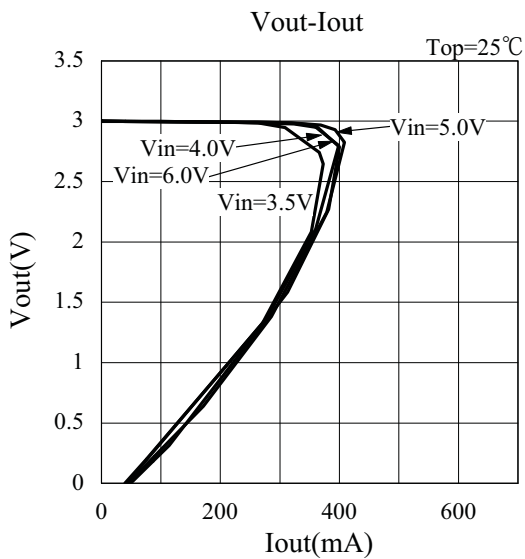
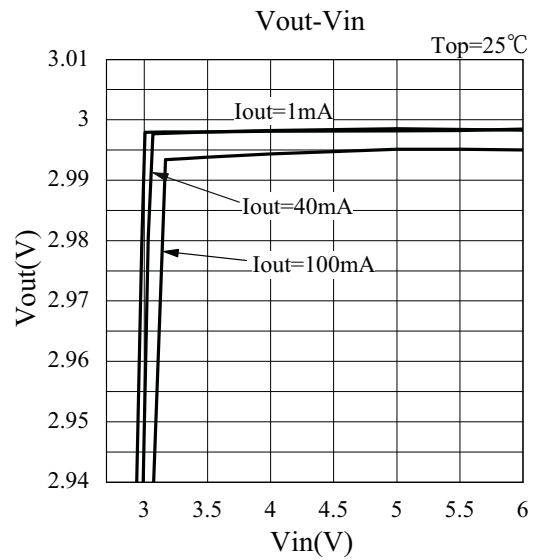
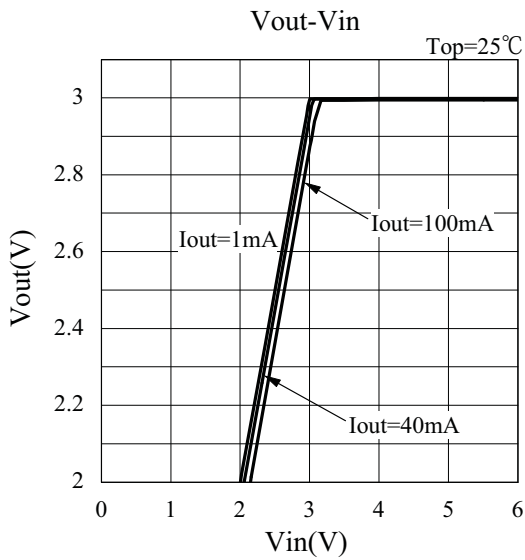

# ELM87xxxxA 1 $\mu$ A Low power consumption CMOS 300mA V/R

<https://www.elm-tech.com>

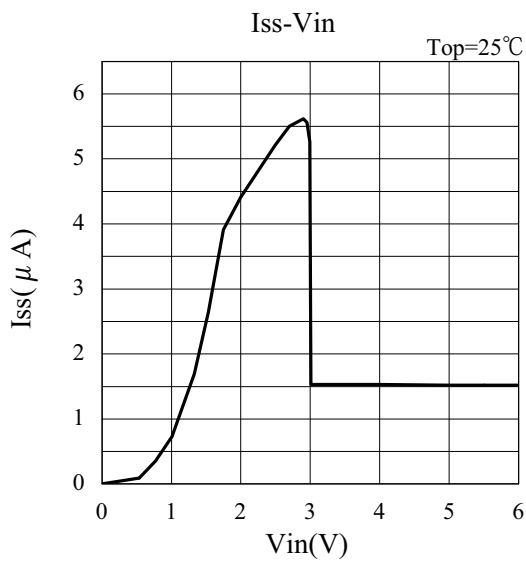
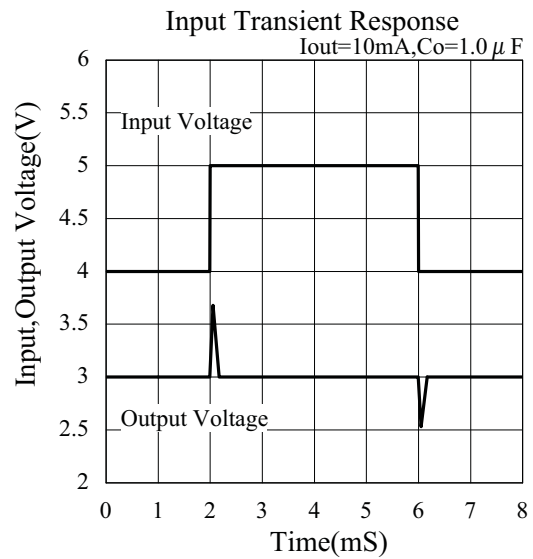
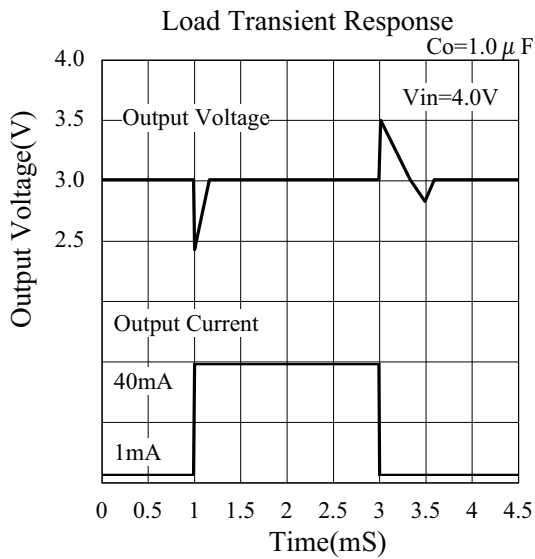

# ELM87xxxxA 1 $\mu$ A Low power consumption CMOS 300mA V/R

<https://www.elm-tech.com>

- 3.3V Vout unit (ELM8733xA, ELM87333xA) Ci=1.0 $\mu$ F, Co=1.0 $\mu$ F, Top=25 $^{\circ}$ C

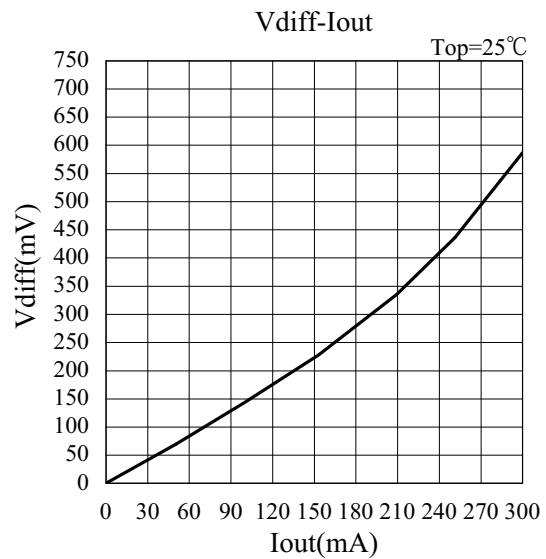
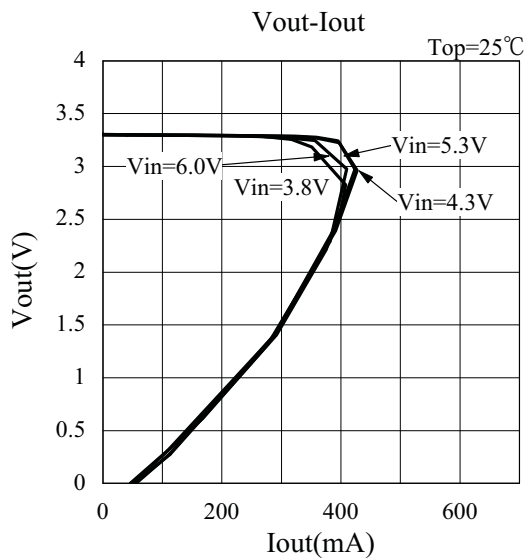
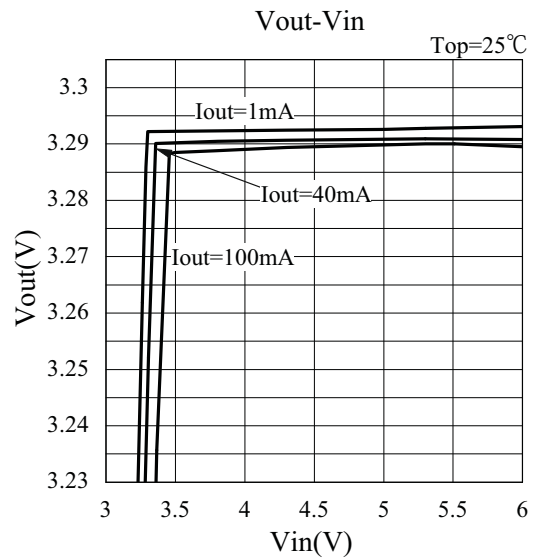
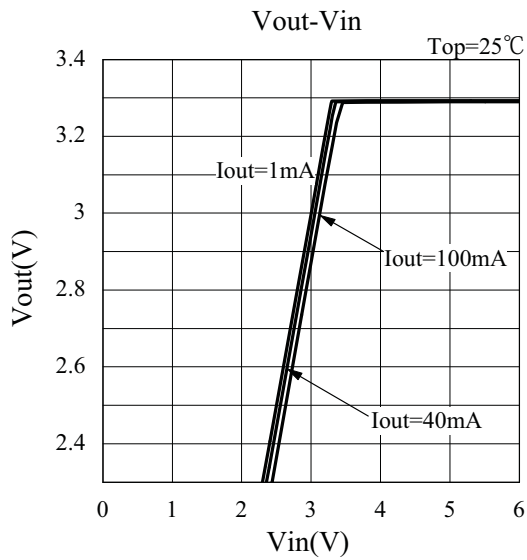

# ELM87xxxxA 1 $\mu$ A Low power consumption CMOS 300mA V/R

<https://www.elm-tech.com>

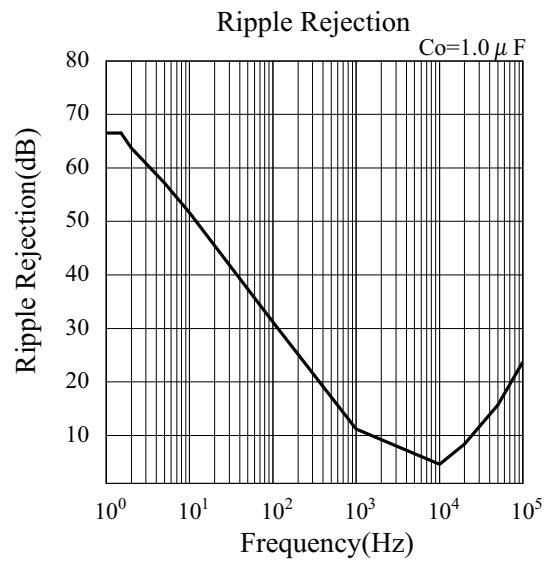
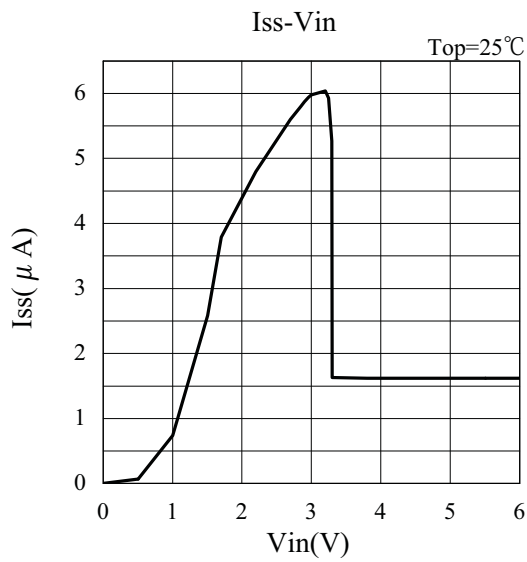
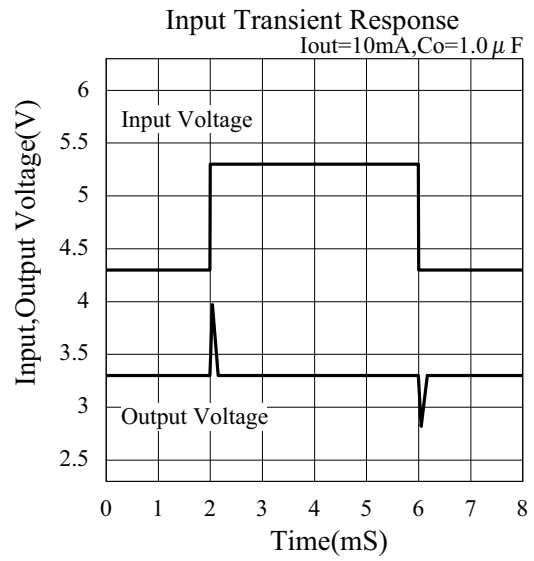
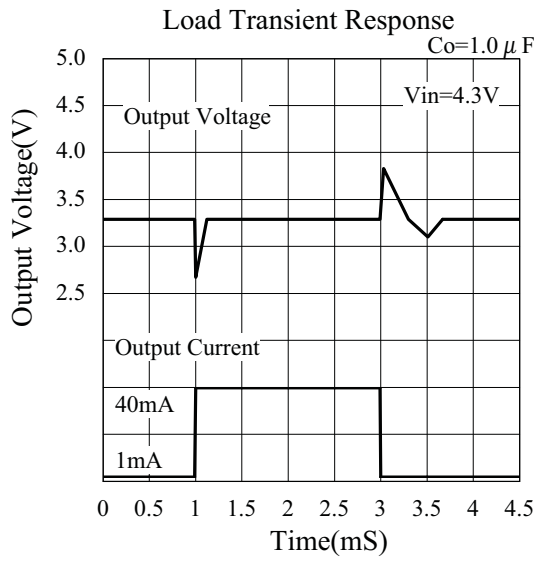



# ELM87xxxxA 1 $\mu$ A Low power consumption CMOS 300mA V/R

<https://www.elm-tech.com>

- 5.0V Vout unit (ELM8750xA, ELM87503xA) Ci=1.0 $\mu$ F, Co=1.0 $\mu$ F, Top=25 $^{\circ}$ C

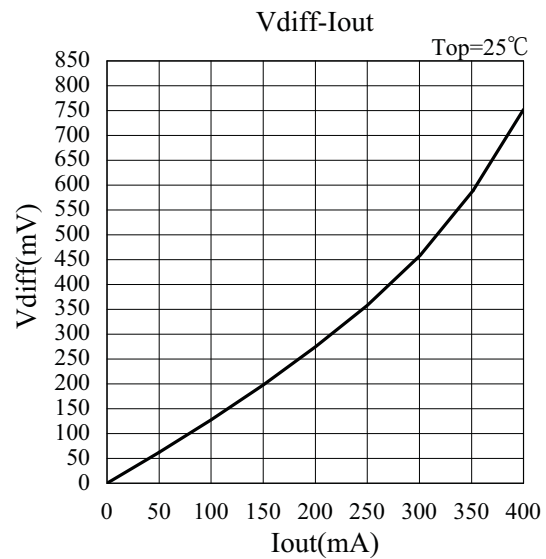
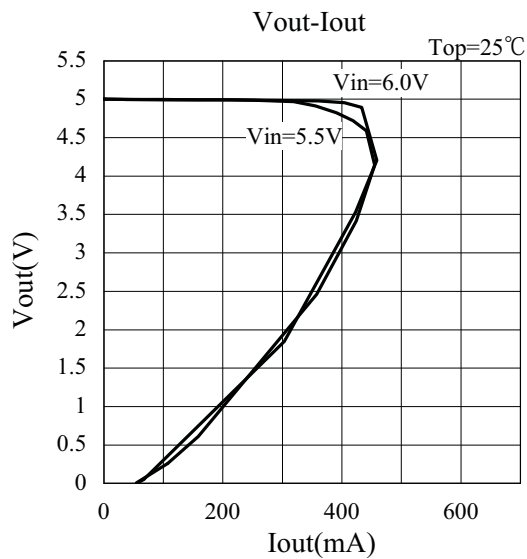
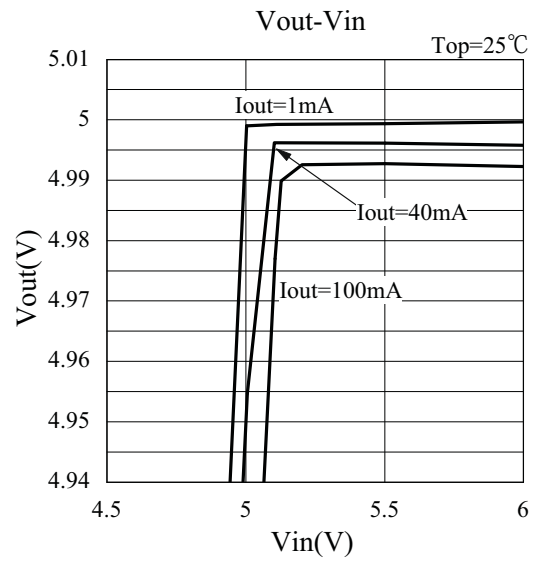
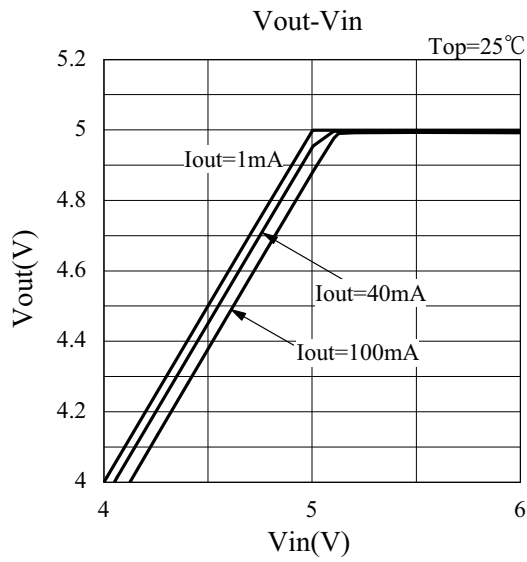

# ELM87xxxxA 1 $\mu$ A Low power consumption CMOS 300mA V/R

<https://www.elm-tech.com>

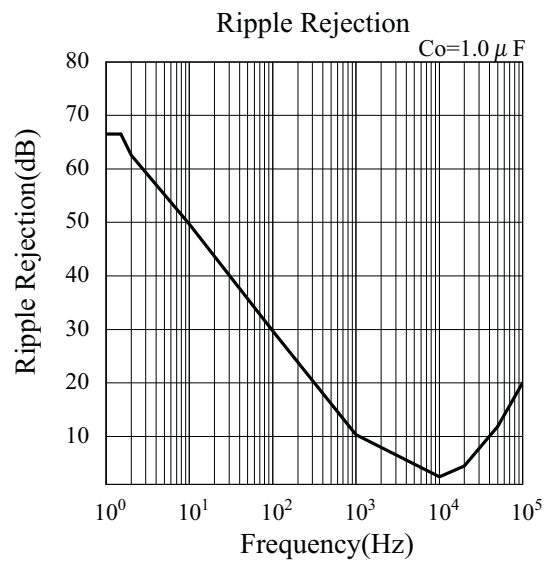
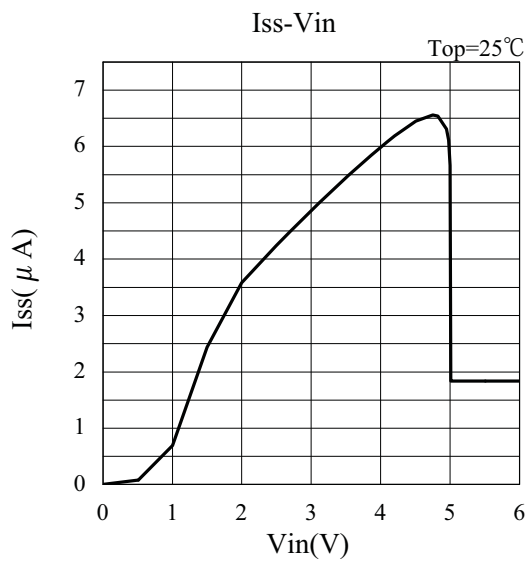
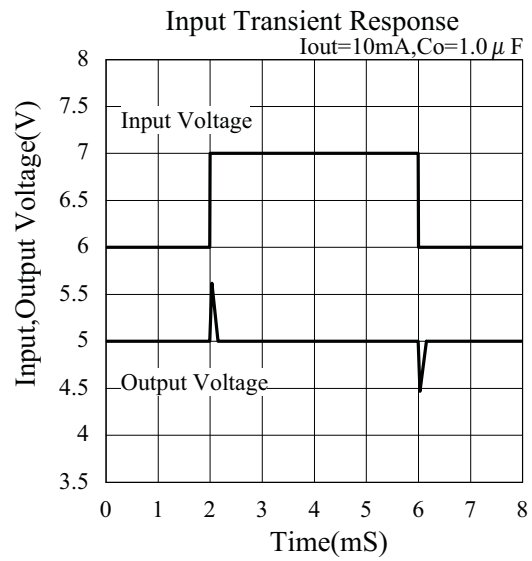
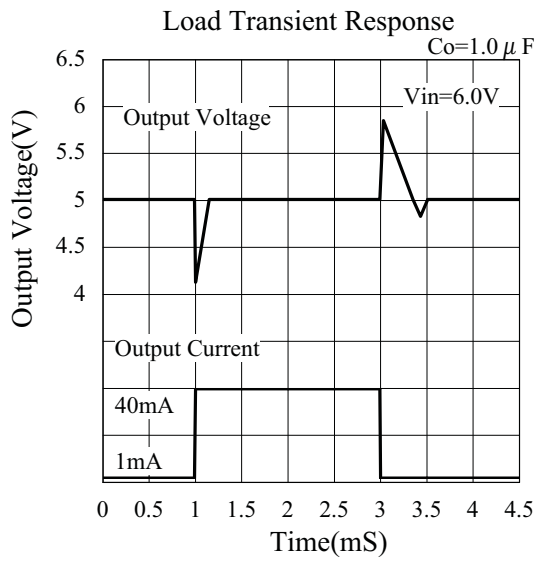

# ELM87xxxxA 1μA Low power consumption CMOS 300mA V/R

<https://www.elm-tech.com>

- ELM87xx3xA

