

ELM631FA 28Vin up to 6A synchronous 4-switch buck-boost converter

<https://www.elm-tech.com>

■ General description

ELM631FA is a wide input range fully integrated 4-switch synchronous buck-boost converter capable of regulating the output voltage at, above, or below the input voltage. The device employs the patented peak current mode with constant off-time control scheme that significantly simplifies control loop design and offers seamless transition between Buck, Buck-Boost and Boost mode operations. Proprietary inductor DCR current sensing eliminates the need for external current sense resistor and improves system power efficiency. With external compensation, ELM631FA can be optimized to operate with a wide range of input and output voltage at all current levels. ELM631FA comes with internal soft-start, programmable inductor peak current limit, input under-voltage and over-voltage lockout, hiccup mode for short circuit or overload protection and thermal shutdown. The high integration level of ELM631FA offers great ease of use and minimizes the external components as well as board space. ELM631FA is available with a small footprint 5mmx5mm 28-lead QFN package.

■ Features

- Inductor DCR current sensing
- Programmable input switch current limit
- Accurate EN threshold voltage
- Output voltage power good indicator
- Cycle-by-Cycle peak current limit
- Short circuit protection with hiccup mode
- Input voltage range : 3.1V to 28.0V
- Output voltage range : 1.0V to 28.0V
- Switch transistor : 17mΩ/20A Nch MOS×4
- Output current : 5A (Input voltage 4.5V to 20V)
6A (Input voltage 20V or more)
- Efficiency : 97.5%
- Switching frequency : 600kHz
- Thermal shutdown : 155°C
- Package : QFN28-5×5

■ Application

- USB type C hub
- 5V, 9V, 12V, 20V and 24V VDC bus power
- USB-PD and thunderbolt ports for PCs
- Power banks and electronic cigarette
- Tablet computer accessories
- Industrial battery powered systems

■ Standard circuit

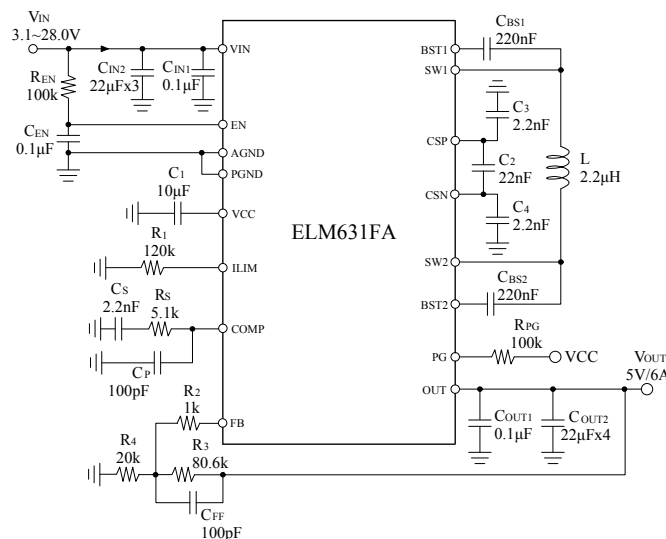

ELM631FA 28Vin up to 6A synchronous 4-switch buck-boost converter

<https://www.elm-tech.com>

■ Maximum absolute ratings ⁽¹⁾

Parameter	Symbol	Limit	Unit
VIN-AGND Supply voltage	V _{IN}	-0.3 to +30.0	V
VOU-AGND Supply voltage	V _{OUT}	-0.3 to +30.0	V
EN-AGND Supply voltage	V _{EN}	-0.3 to +30.0	V
CSP-AGND Supply voltage	V _{CSP}	-0.3 to +30.0	V
CSN-AGND Supply voltage	V _{CSN}	-0.3 to +30.0	V
CSP-CSN Supply voltage	V _{CSP-CSN}	-0.3 to +0.3	V
SW1-AGND Supply voltage	V _{SW1-AGND}	-0.3 to V _{IN} +0.6	V
Dynamic SW1 in 50ns duration	V _{SW1}	-3 to V _{IN} +3	V
SW2-AGND Supply voltage	V _{SW2-AGND}	-0.3 to V _{OUT} +0.6	V
Dynamic SW2 in 50ns duration	V _{SW2}	3 to V _{OUT} +3	V
BST1-SW1 Supply voltage	V _{BST1-SW1}	-0.3 to +6.0	V
BST2-SW2 Supply voltage	V _{BST2-SW2}	-0.3 to +6.0	V
PGND-AGND Supply voltage	V _{PGND-AGND}	-0.3 to +0.3	V
The other pins to AGND	V _{OTHER}	-0.3 to +6.0	V
Lead temperature	T _L	+260	°C
Junction temperature range	T _J	-40 to +150	°C
Storage temperature range	T _{STG}	-55 to +150	°C
Thermal resistance ^{(3), (4)}	θ _{JA}	35.6	°C/W
Thermal resistance ^{(3), (4)}	θ _{JC}	12.0	
Power dissipation ^{(3), (4)}	P _D	3.5	W

■ Recommend operating conditions ⁽²⁾

Parameter	Symbol	Limit	Unit
Input voltage	V _{IN}	+3.1 to +28.0	V
Output voltage	V _{OUT}	+1 to 28	V
Operating temperature range	T _{OP}	-40 to +85	°C

Note:

- (1) Stress exceeding those listed “Maximum absolute ratings” may damage the device.
- (2) The device is not guaranteed to function outside of the recommended operating conditions.
- (3) Measured on JESD51-7, 4-Layer PCB.
- (4) The maximum allowable power dissipation is a function of the maximum junction temperature T_{J_MAX}, the junction to ambient thermal resistance θ_{JA}, and the ambient temperature T_A. The maximum allowable continuous power dissipation at any ambient temperature is calculated by P_{D_MAX} = (T_{J_MAX} - T_A) / θ_{JA}. Exceeding the maximum allowable power dissipation will cause excessive die temperature, and the regulator will go into thermal shutdown. Internal thermal shutdown circuitry protects the device from permanent damage.

ELM631FA 28Vin up to 6A synchronous 4-switch buck-boost converter

<https://www.elm-tech.com>

■ Selection guide

ELM631FA-N

Symbol		
a	Part No.	ELM631
b	Package	F: QFN28-5×5
c	Product version	A
d	Taping direction	N: Please refer to page 22

ELM631 F A - N
 ↑ ↑ ↑
 a b c

* Taping direction is one way.

■ Pin configuration

QFN28-5×5(TOP VIEW)

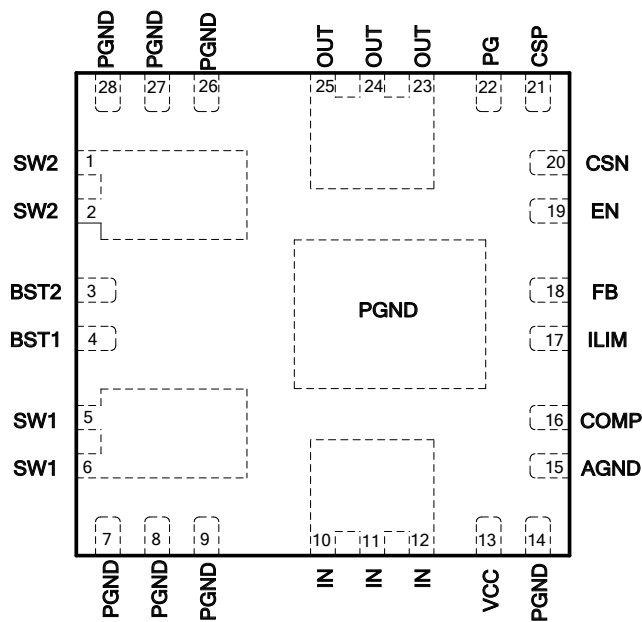

ELM631FA 28Vin up to 6A synchronous 4-switch buck-boost converter

<https://www.elm-tech.com>

PIN No.	Symbol	Pin description
1, 2	SW2	Output path switching pin, connect to one end of the power inductor.
3	BST2	Output path high side MOSFET gate driver supply. Connect a 220nF ceramic capacitor between BST2 and SW2 pins.
4	BST1	Input path high side MOSFET gate driver supply. Connect a 220nF ceramic capacitor between BST1 and SW1 pins.
5, 6	SW1	Input path switching pin, connect to the other end of the power inductor.
7, 8, 9, 14 26, 27, 28	PGND	Power ground of the converter. Use wide and short connection to EVB power ground plane. Connect this pin to the bottom plates of C _{IN} and C _{OUT} capacitors.
10, 11, 12	IN	Input supply of the converter.
13	VCC	5V On-Chip Low Dropout Linear Regulator Output (LDO). This regulator powers all internal circuitries including 4-switch gate drivers. Connect a 10μF ceramic cap between VCC to AGND for stable operation. This pin is not intended for supplying any external load.
15	AGND	Analog ground of the converter control circuit. Connect AGND to PGND at 1 place of EVB power ground plane.
16	COMP	Output of the trans-conductance amplifier. Connect to external R-C network for loop compensation of the converter
17	ILIM	Programmable inductor peak current limit. Connect a programming resistor to ground.
18	FB	Feedback pin for output voltage regulation. Connect FB to the center tap of a resistor divider to set the output voltage.
19	EN	Enable pin of the converter. Pull EN above 1.45V to enable the converter; pull EN below 1.35V to disable the converter. EN pin can be used to implement externally adjustable input under voltage lockout (UVLO) with a resistor divider from input. Connect EN to the center tap of the resistor divider to set the input UVLO threshold.
20	CSN	Negative input of current sense amplifier for DCR sensing. Refer to DCR sensing section for external sense circuitry selection.
21	CSP	Positive input of current sense amplifier for DCR sensing. Refer to DCR sensing section for external sense circuitry selection.
22	PG	Open drain power good output pin. Open-drain output that is pulled to ground when the output voltage is 10% below the regulated output voltage. A 100kΩ pull-up resistor is recommended between PGOOD and VCC.
23, 24, 25	OUT	Output pin of the converter.
EP	PGND	Exposed pad. Connect EP to PGND.

ELM631FA 28Vin up to 6A synchronous 4-switch buck-boost converter

<https://www.elm-tech.com>

■Block diagram

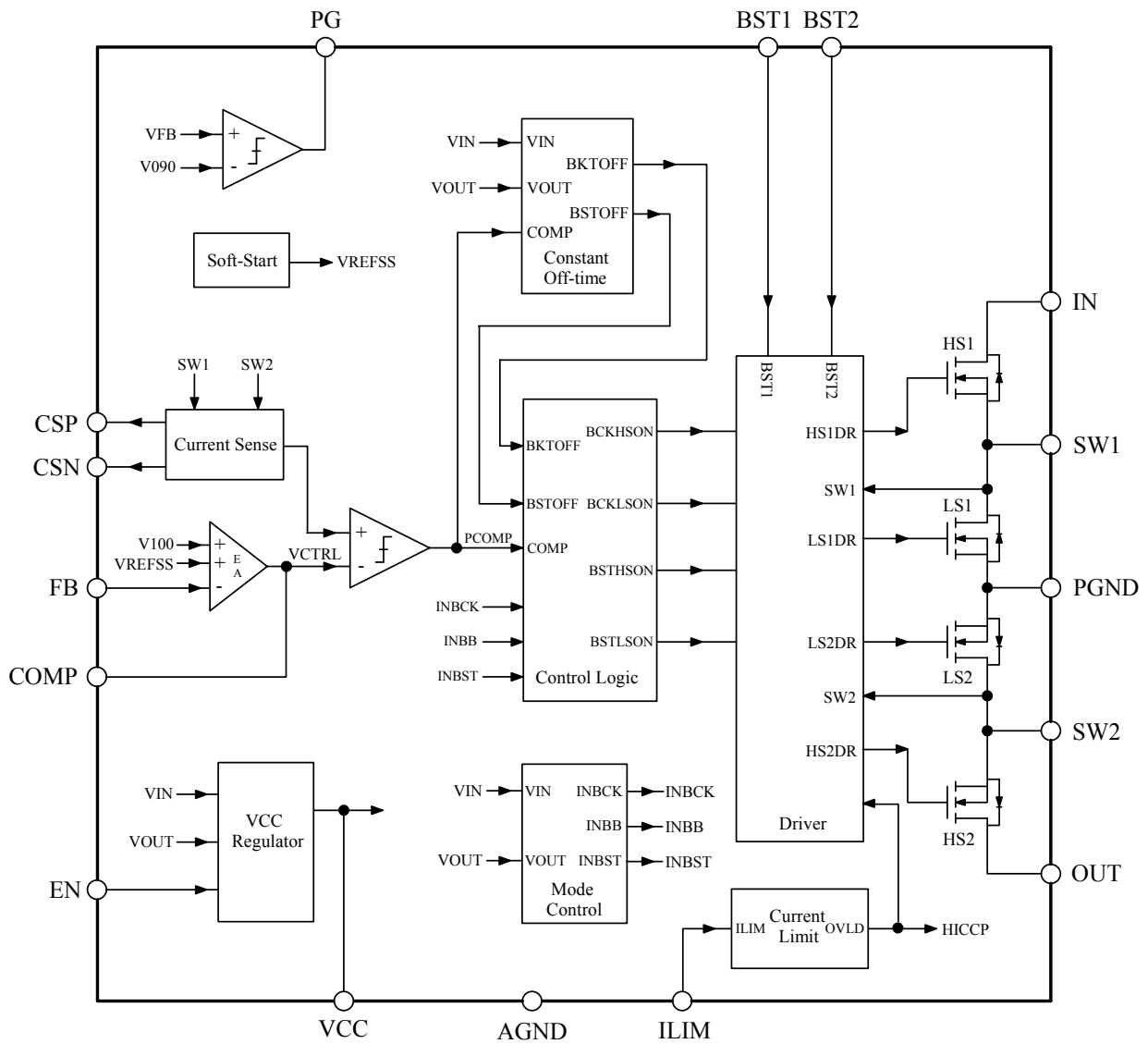

■Marking

QFN28-5x5

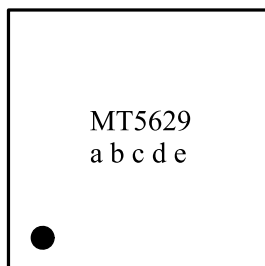

Mark	Content
MT5629	Product ID
a to e	Assembly lot No.

ELM631FA 28Vin up to 6A synchronous 4-switch buck-boost converter

<https://www.elm-tech.com>

■Electrical characteristics

$T_{OP}=+25^{\circ}C$, unless otherwise noted. Typical values are at $V_{IN}=12V$, $V_{OUT}=V_{EN}=5.0V$.

Parameter	Symbol	Test conditions	Min.	Typ.	Max.	Unit
Operating input voltage	V_{IN}		3.1	-	28.0	V
Operating output voltage	V_{OUT}		1	-	28	V
Input shutdown current	I_{SDIN}	$EN = 0V, 4V \leq V_{IN} \leq 28V$	-	1	5	μA
Input quiescent current	I_{QIN}	$V_{EN}=5V, V_{FB}=1.1V$ $4V \leq V_{IN} \leq 28V$	-	1.2	1.8	mA
Input under voltage lockout threshold	V_{INUV}	V_{IN} increasing	2.7	2.9	3.1	V
Input under voltage lockout hysteresis	$V_{INUVHYS}$	Falling hysteresis	-	220	-	mV
Input over voltage protection threshold	V_{INOV}	V_{IN} increasing	28	31	34	V
Input over voltage protection hysteresis	$V_{INOVHYS}$	Falling hysteresis	-	1.75	-	V
VCC output voltage	V_{CC}	With no external load $V_{IN}>5.5V$	4.9	5.2	5.5	V
VCC drop out voltage	V_{CCDO}	VCC source 30mA	-	400	-	mV
EN High threshold voltage	V_{ENH}		1.30	1.45	1.60	V
EN Low threshold voltage	V_{ENL}		1.20	1.35	1.50	V
EN shutdown threshold	V_{ENSD}		-	-	0.4	V
EN pull down resistor	R_{EN}		0.7	1.0	1.3	$M\Omega$
Feedback reference voltage	V_{FB}		0.985	1.000	1.015	V
Feedback input current	I_{FB}	$V_{FB}=1.02V$	-50	-	50	nA
Error amp transconductance	G_{MEA}	$0.98V < V_{FB} < 1.02V$	160	200	240	μS
COMP Max. sourcing current	I_{SRCEA}	$V_{FB}=0.8V$	60	80	100	μA
COMP Max. sinking current	I_{SNKEA}	$V_{FB}=1.15V$	60	90	120	μA
COMP pull-down current	I_{PDEA}	$V_{FB}=1.2V$	240	280	320	μA
Internal soft-start time (Note 1)	T_{SS}		-	2	-	ms
Switching frequency	f_{SWBK}	$V_{IN}=12V, V_{OUT}=5V, I_{OUT}=2A$	450	600	750	kHz
	f_{SWBS}	$V_{IN}=5V, V_{OUT}=12V, I_{OUT}=1A$	500	650	800	kHz
HS switch on resistance (Note 1)	R_{ONHS}		-	17	-	$m\Omega$
LS switch on resistance (Note 1)	R_{ONLS}		-	17	-	$m\Omega$
HS switch leakage current	$I_{LK GHS}$	$V_{EN}=0; V_{IN}=V_{OUT}=28V$ $V_{SW1}=V_{SW2}=0V$	-	10	50	nA
LS switch leakage current	$I_{LK GLS}$	$V_{EN}=0; V_{IN}=V_{OUT}=28V$ $V_{SW1}=V_{SW2}=28V$	6	12	18	μA
Programmable peak current limit threshold	V_{HSPKP}	$R_{ILIM}=120k\Omega$	220	270	320	mV
Power good (PG) rise threshold	V_{PGTH}	V_{FB} rising PG: Low to High Z	85	90	95	%
Power good (PG) falling hysteresis	V_{PGHYS}	V_{FB} falling PG: High Z to Low	-	3	-	%
PGOOD PG output low voltage	V_{PGLO}	$V_{FB}=0.8V, PG$ sink 1mA	-	0.2	0.3	V
PGOOD PG leakage current	$I_{LK GPG}$	$V_{FB}=1.1V, V_{PG}=5V$	-	10	100	nA
CSP/CSN input current	I_{CSP}, I_{CSN}	$V_{EN}=2V; V_{IN}=V_{OUT}=12V$ $V_{CSP}=V_{CSN}=5V$	3	6	9	μA
Current sense amplifier gain	ACS	$V_{CSP}-V_{CSN}=50mV$	10	12	14	V/V
Internal thermal shutdown threshold	T_{SD}	(Note1)	-	155	-	$^{\circ}C$
Internal thermal shutdown hysteresis	T_{SDHYS}	(Note1)	-	30	-	$^{\circ}C$

Note1: Guaranteed by design.

ELM631FA 28Vin up to 6A synchronous 4-switch buck-boost converter

<https://www.elm-tech.com>

■ Typical characteristics

- $C_{IN}=0.1\mu F+22\mu F \times 3$, $C_{OUT}=0.1\mu F+22\mu F \times 4$, $L=2.2\mu H$, $T_A=+25^\circ C$ (Refer to 5V_{OUT} circuit)

Efficiency vs. Output Current (5Vo)

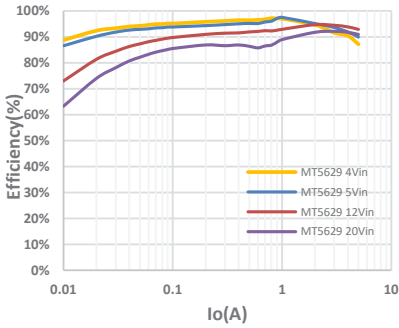

Efficiency vs. Input Voltage (5Vo)

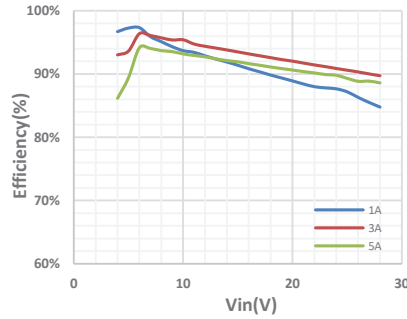

Quiescent Current vs. Input Voltage

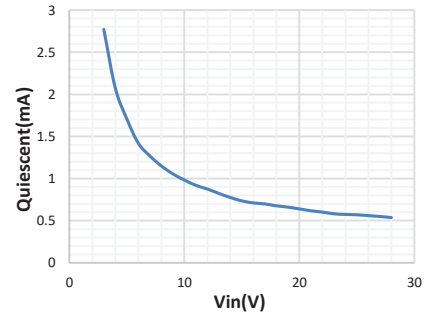

Steady State Test (Boost)

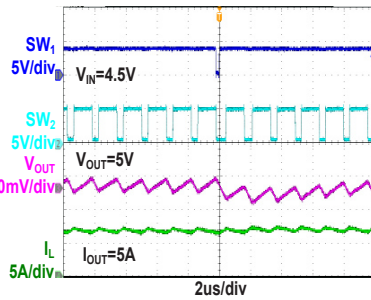

Steady State Test (Buck-Boost)

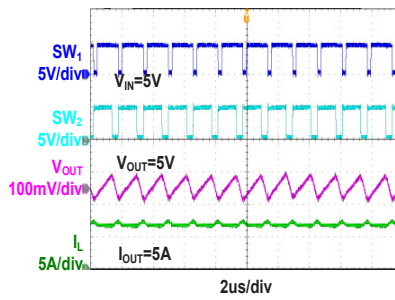

Steady State Test (Buck)

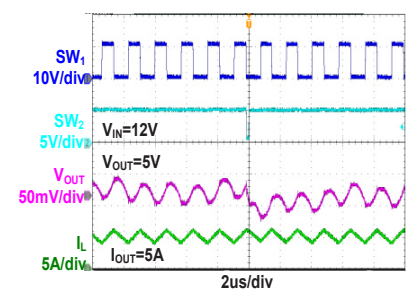

Steady State Test (Buck)

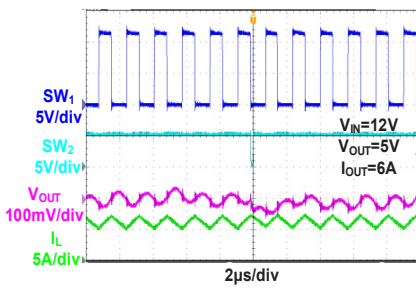

Steady State Test (Buck)

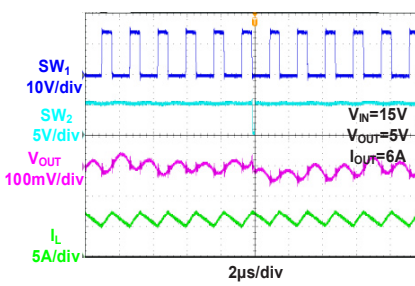

Steady State Test (Buck)

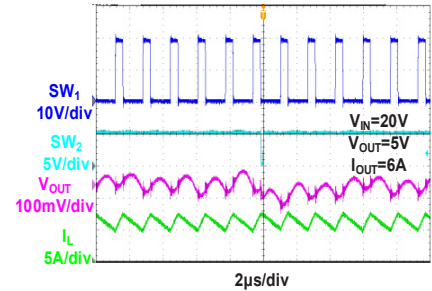

ELM631FA 28Vin up to 6A synchronous 4-switch buck-boost converter

<https://www.elm-tech.com>

- $C_{IN}=0.1\mu F+22\mu F \times 3$, $C_{OUT}=0.1\mu F+22\mu F \times 4$, $L=2.2\mu H$, $T_A=+25^\circ C$ (Refer to 5V_{OUT} circuit)

Short Protection (Boost)

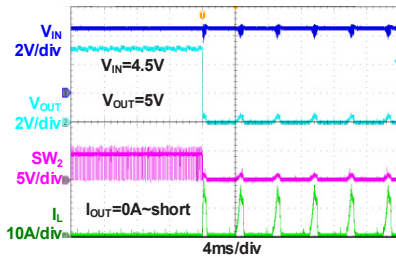

Short Protection (Boost)

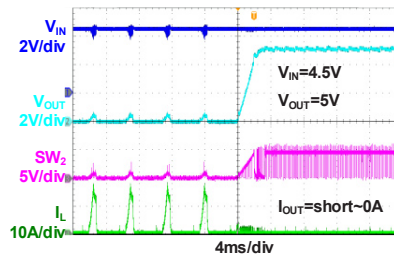

Short Protection (Buck-Boost)

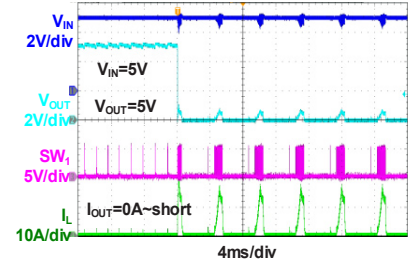

Short Protection (Buck)

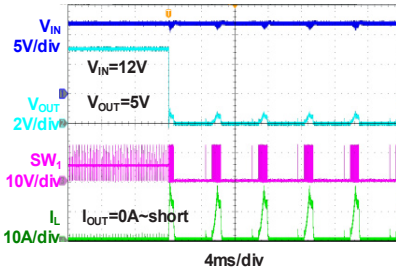

Short Protection (Buck)

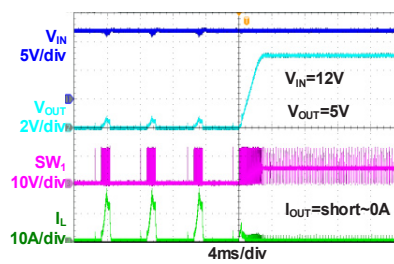

Short Protection (Buck-Boost)

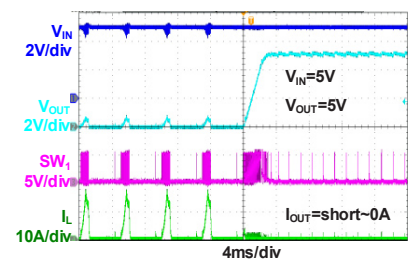

EN Power on (Boost)

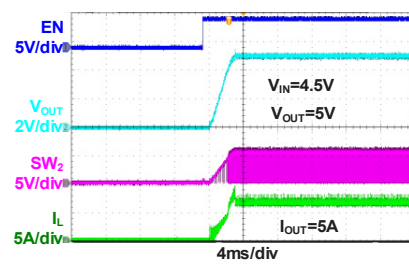

EN Power off (Boost)

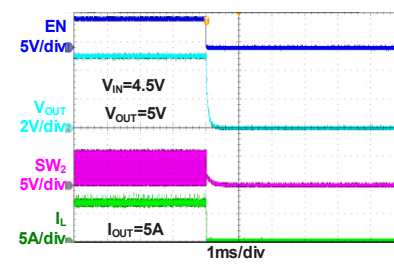

EN Power on (Buck-Boost)

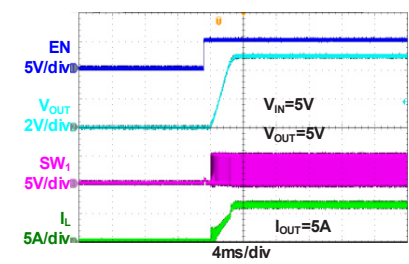

ELM631FA 28Vin up to 6A synchronous 4-switch buck-boost converter

<https://www.elm-tech.com>

- $C_{IN}=0.1\mu F+22\mu F \times 3$, $C_{OUT}=0.1\mu F+22\mu F \times 4$, $L=2.2\mu H$, $T_A=+25^\circ C$ (Refer to 5V_{OUT} circuit)

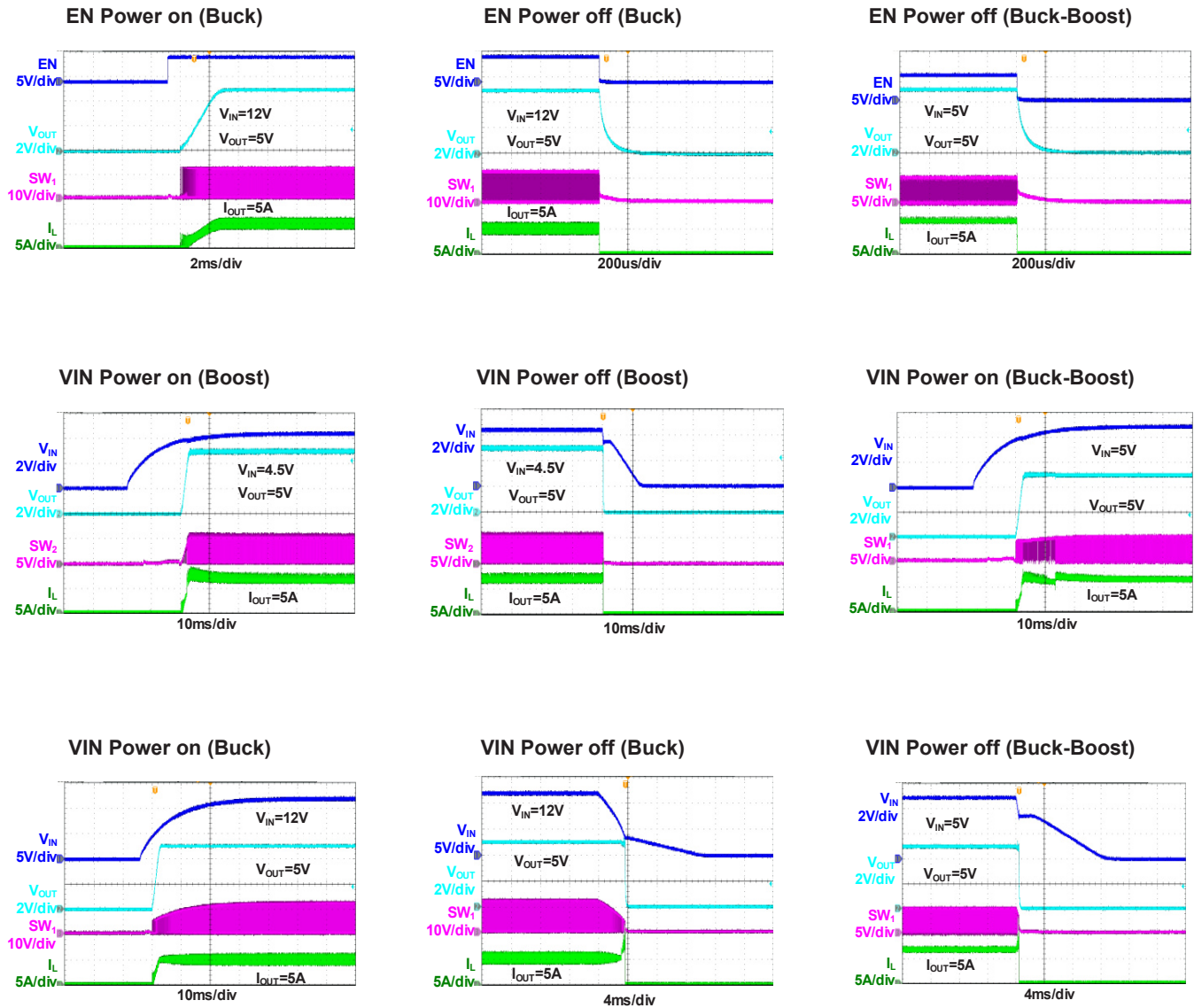

ELM631FA 28Vin up to 6A synchronous 4-switch buck-boost converter

<https://www.elm-tech.com>

■ Operation

Overview

The ELM631FA is a wide input range fully integrated 4-switch Buck-boost converter with up to 6A output current. With patented peak current mode constant off-time control (PCM-COT), ELM631FA can operate in Buck, Buck-boost or Boost mode and offers seamless transition between the three operation modes. Specifically, it operates in Buck mode when the input is higher than the output, and in Boost mode when the input is lower than the output. When the input and output are close to each other, ELM631FA operates in a proprietary Buck-boost mode that controls all four switches to modulate inductor ripple current hence achieves minimum output voltage ripple.

Peak current mode constant off-time control

The patented Peak Current Mode Constant Off-time Control (PCM-COT) combines the advantage of flexible loop compensation of the current mode control and smooth transition of the constant off-time control. During normal operation when each switching cycle starts, the peak current mode control circuit compares the sensed inductor current VCS with the control voltage VCTRL from the error amplifier. Once the VCS reaches the VCTRL level, the control circuit terminates the main power switches, i.e. the HS of Buck mode (HS1) or the LS of Boost mode (LS2), and then immediately turns on the synchronous power switches, i.e. the LS of Buck mode (LS1) or the HS of Boost mode (HS2). the moment when the synchronous power switches are turned on, the off-time timers for Buck mode and Boost mode respectively start to count. When either timer times out, the main power switches, either HS1 or LS2 depending on operation mode, are turned on to initiate the next switching cycle.

When V_{IN} is higher than V_{OUT} by typ. 10% or more, ELM631FA operates in Buck mode. In this mode, during normal switching cycles, the LS2 switch remains off and the HS2 switch is kept fully on, while the HS1 and LS1 switches alternatively the same way as normal Buck converters. To keep HS2 fully on for the Buck mode operation, its floating supply BST2 voltage needs to be periodically recharged, ELM631FA has built BST refresh function, which turns off HS2 and turn on LS2 for about 150ns in roughly every 240µs for the BST2 voltage to be recharged.

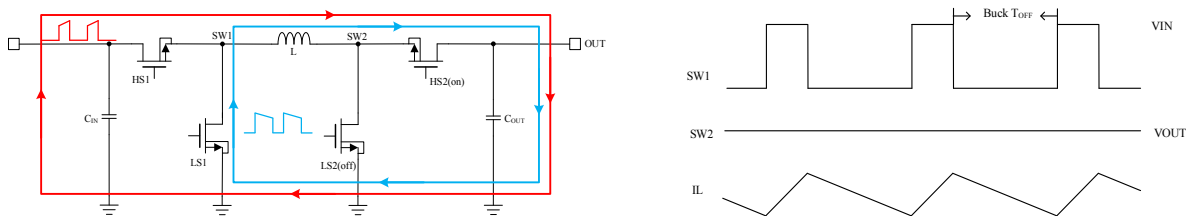

Buck Mode

When V_{IN} and V_{OUT} are close to each other within typ. 10% range, ELM631FA operates in Buck-boost mode where all four switches are involved in switching in a specific order. First, HS1 is turned on to start the Buck mode where the HS2 is already on from previous switching cycle. The Buck mode occupies about 90% of the switching cycle. While HS2 is on, the Boost off-timer is counting and when it times out, then the Boost mode starts which turns off HS2 and turns on LS2. Once LS2 is turned on, the inductor current starts to ramp up sharply and so is VCS. When VCS rises up to reach VCTRL level, the HS1 and LS2 are turned off simultaneously by the peak current mode control logic and LS1 and HS2 are turned on which starts the Buck off-time and Boost off-timer respectively. The Boost mode occupies about 10% of the switch cycle. Once the Buck off-timer times out, the LS1 is turned off and the HS1 is turned on to start the next switching cycle.

ELM631FA 28Vin up to 6A synchronous 4-switch buck-boost converter

<https://www.elm-tech.com>

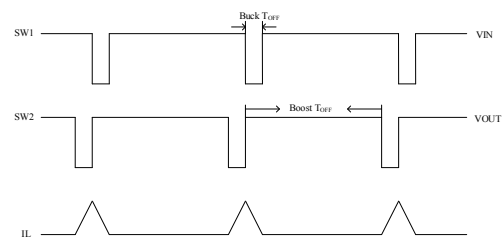
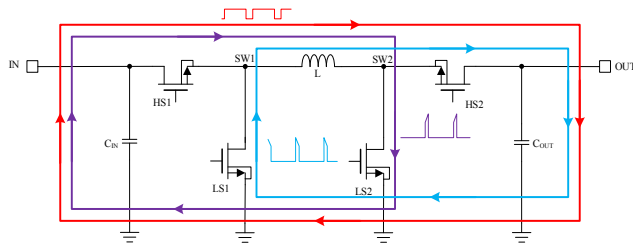

Buck-Boost Mode

When V_{IN} is lower than V_{OUT} by typ. 10% or more, ELM631FA operates in Boost mode. In this mode, during normal switching cycles, the HS1 switch is kept fully on and the LS1 switch remains off, while the LS2 and HS2 switches alternatively the same way as normal Boost converters. To keep HS1 fully on for the Boost mode operation, its floating supply BST1 voltage needs to be periodically recharged. ELM631FA has built-in BST refresh function, which turns off HS1 and turns on LS1 for about 150ns in roughly every 240 μ s for the BST1 voltage to be recharged.

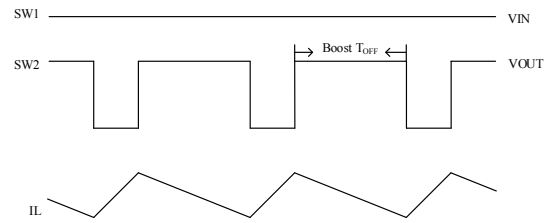
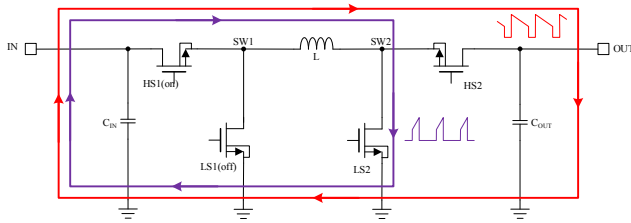

Boost Mode

The patented PCM-COT control adds a proprietary four-switch Buck-boost mode, thus provides a natural and smooth transition between the Buck mode and Boost mode operations.

Inductor DCR current sense

The peak current mode section of the PCM-COT control requires sensing the inductor current for processing. The ELM631FA uses a proprietary design to sense the inductor DCR current that only requires three external capacitors, eliminating the need for an external sense resistor, hence reduces system cost and improves system power efficiency. The equivalent circuit of the current sense block is shown in Fig. 3. For different choices on the inductors and its DCR value, the external capacitors can be calculated following the guidance below:

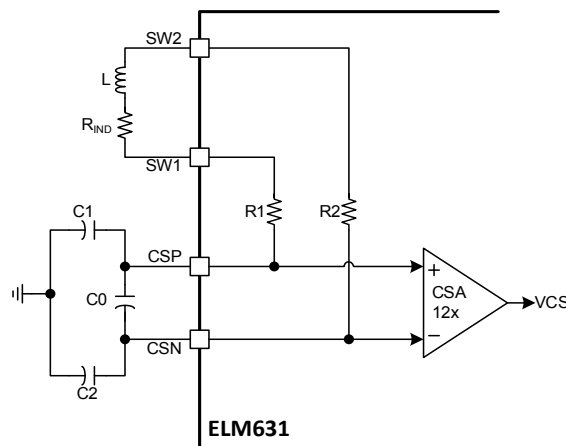

Fig. 3

ELM631FA 28Vin up to 6A synchronous 4-switch buck-boost converter

<https://www.elm-tech.com>

First, calculated the required equivalent capacitance needed between CSP and CSN pin:

$$C_{EQ} = (0.5 - 1.5) \cdot L / (R_{IND} \cdot 15k)$$

where R_{IND} is the DCR of the inductor

Then the recommended choice for the three external capacitors are:

$$C_0 \approx (0.7 \sim 0.9) \cdot C_{EQ}$$

$$C_1=C_2 \approx (C_{EQ} - C_0) \cdot 2$$

Programmable current limit

ELM631FA monitors the voltage drop across the HS1 switch during its on period to limit the peak current of the converter. When the HS1 drain-source voltage drop V_{DSHS1} exceeds the threshold voltage V_{HSPK} , the HS1 switch is immediately turned off to prevent its current going over the limit. ELM631FA allows the user to program the V_{HSPK} threshold voltage through the ILIM pin, hence set the desired input HS switch (HS1) current limit.

The desired current limit can be programmed with following table:

$$I_{HSPK} = (30k / R_{LIM}) / R_{ONHS} + 500mA$$

Where R_{ONHS} is the HS1 switch on resistance, typical 17m Ω .

Due to the wide range of input operation voltage and external component selection, the actual peak current limit might be slightly different from the above calculated value. Nonetheless, the equation provides a good estimate for the typical current limit.

Light load operation

For light load conditions, ELM631FA automatically enters into pulse frequency modulation (PFM) mode where ELM631FA operates at a reduced frequency and turns off the synchronous switches, i.e., the LS1 for Buck or HS2 for Boost or both for Buck-boost mode, when the inductor current drops to zero during each switching cycle. The PFM mode significantly reduces the switching losses thus improving the power efficiency at light load conditions.

Soft start

ELM631FA comes with a built-in 2ms soft-start. During the soft start period, the output voltage is ramped up linearly to the regulation level, independent of the load current level and output capacitor value.

Power good indication

ELM631FA comes with open drain power good indicator PG pin. When connected to a pull up resistor, the PG pin will be pulled up if the output voltage rises above typ. 90% of regulation. When the output voltage falls below typ. 87% of the regulation, the PG pin is pulled low by the internal open drain NMOS.

Short circuit protection

ELM631FA has cycle-by cycle current limit protection to prevent the HS1 switch and the inductor current from running away. When the HS1 switch is turned on, its voltage drop is compared with a threshold voltage V_{HSPK} to monitor its current level. Once the HS1 switch reaches the current limit level, ELM631FA immediately turns off the main power switches, which is the HS1 for Buck mode, LS2 for Boost mode and both for Buck-boost mode. Then the synchronous switches, i.e., the LS1 for Buck, HS2 for Boost and both for Buck-boost, are turned on to ramp down the inductor current. The synchronous switches stay on until the inductor current drops

ELM631FA 28Vin up to 6A synchronous 4-switch buck-boost converter

<https://www.elm-tech.com>

down to typ. 90% of the peak current level, at which point the main switches are allowed to turn on again to start the next switching cycle. If this current limit condition sustains for a long period of time, typical 500µs, ELM631FA will consider it as over-load or short circuit. Either way, ELM631FA will enter hiccup mode, where it stops switching for a pre-determined period of time, typically 2ms, before automatically re-try to start up again. It always starts up with soft-start to limit inrush current and avoid output voltage overshoot.

Input Over Voltage Protection(IOVP) and Input Under Voltage Lockout(UVLO)

ELM631FA stops its switching operation when VIN pin voltage is exceeding 28V or below 3.1V to prevent error operation of the IC circuit. After input voltage recovered to normal range the IC resumes. There are internal hysteresis voltages for each protection voltage level.

■Application information

Setting output voltage

The output voltage of ELM631FA can be set by connecting the FB pin to a resistor divider between the output and ground, as shown in AP circuit below. The output voltage (VOUT) can be calculated according to the voltage of the FB pin (VFB=1.0V typical):

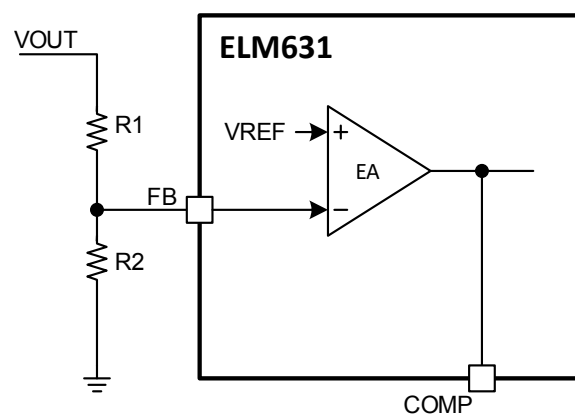

$$V_{OUT} = V_{FB} \cdot \left(\frac{R1}{R2} + 1 \right)$$

Designing loop compensation

ELM631FA employs Peak Current Mode Constant Off-Time (PCM-COT) control, thus it has similar loop transfer function as traditional Peak Current Mode (PCM) controlled converters. Specifically, the power train of the inductor and output capacitor can be modeled as a first-order system consists of a voltage controlled current source and the output capacitor, thanks to the peak current regulation loop of the PCM control. For ELM631FA, the transconductance of the voltage controlled current source is determined the inductor DCR the current sense gain.

ELM631FA has three modes of operations: Buck mode, Boost mode and Buck-boost mode which should all be considered when designing the loop compensation network.

ELM631FA 28Vin up to 6A synchronous 4-switch buck-boost converter

<https://www.elm-tech.com>

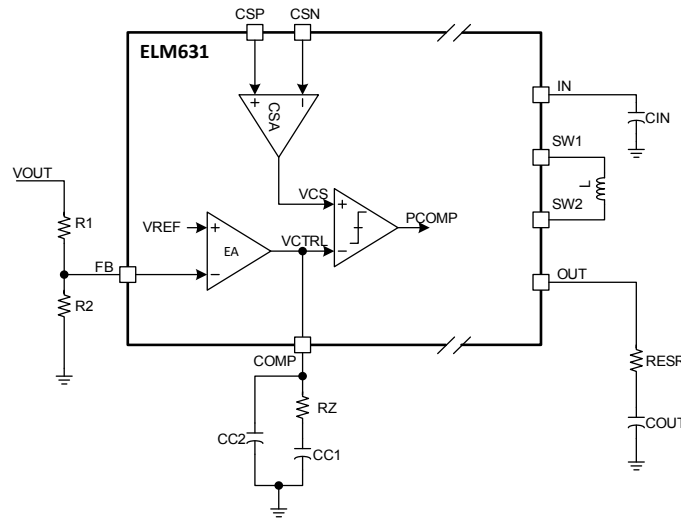

Due to the Right Half Plane (RHP) zero in boost mode operation, boost mode usually limits the achievable loop bandwidth. With this in mind, the typical loop bandwidth is recommended to about one fourth of RHP zero frequency. In a Boost converter, the RHP zero is given by:

$$f_{RHPZ_{BOOST}} = \frac{1}{2 \cdot \pi} \frac{R_L \cdot (1 - D_{MAX})^2}{L} = \frac{1}{2 \cdot \pi} \cdot \frac{V_{OUT}}{I_{LOAD}} \frac{(1 - D_{MAX})^2}{L}$$

Where R_L is the equivalent load impedance, i.e. $R_L = V_{OUT}/I_{LOAD}$; D_{MAX} is the maximum duty cycle of the converter for its applicable applications.

If we set the loop bandwidth to one fourth of the RHP:

$$f_{BW_{BOOST}} = \frac{1}{4} = \frac{1}{2 \cdot \pi} \cdot \frac{V_{OUT}}{I_{LOAD}} \frac{(1 - D_{MAX})^2}{L}$$

The loop bandwidth of ELM631FA Boost mode can also be obtained by:

$$f_{BW_{BOOST}} = \frac{1}{2 \cdot \pi} G_{mEA} \cdot R_Z \cdot \frac{(1 - D_{MAX})}{A_{CS} \cdot R_{DCR} \cdot C_{OUT}} \cdot \frac{V_{FB}}{V_{OUT}} = \frac{1}{2 \cdot \pi} 14.4\mu \cdot (1 - D_{MAX}) \cdot R_Z \cdot \frac{1}{R_{DCR} \cdot C_{OUT}} \cdot \frac{V_{FB}}{V_{OUT}}$$

To set loop bandwidth at one fourth of the RHP zero, we can calculate R_Z as:

$$R_Z = 17k \cdot \frac{V_{OUT}}{I_{LOAD}} \frac{(1 - D_{MAX})}{L} \cdot R_{DCR} \cdot C_{OUT} \cdot \frac{V_{OUT}}{V_{FB}}$$

Once R_Z is obtained, we can quickly calculate the $CC1$ and $CC2$.

Place the zero formed by R_Z and $CC1$ to $\sim 1/5$ of the bandwidth to bring back the phase shift from the output pole:

$$CC1 = \frac{5}{2\pi \cdot f_{BW_{BOOST}} \cdot R_Z}$$

Place the pole formed by R_Z and $CC2$ to $\sim 5X$ of the bandwidth to suppress high frequency noise:

$$CC2 = \frac{1}{5} \cdot \frac{1}{2\pi \cdot f_{BW_{BOOST}} \cdot R_1}$$

The above guideline of the compensation network design shall give a good reference to have stable operation of ELM631FA. However, due to the wide range of operation condition for both and output voltage and load current level, in some cases, the compensation network might still need to be adjusted to get optimal performance of ELM631FA.

ELM631FA 28Vin up to 6A synchronous 4-switch buck-boost converter

<https://www.elm-tech.com>

Inductor selection

The selection of the inductor affects the steady-state operation as transient behavior and loop stability. These factors make it an important component in a switching power supply design. The three most important inductor specifications to consider are inductance value, DC resistance (DCR), and saturation current rating. In a step-up topology the average inductor current is equal to the input current. The highest average current through the inductor and the converter depends on the maximum output load, converter efficiency η , the minimum input voltage (V_{INmin}), and the output voltage (V_{OUT}). The inductor saturation current rating should be greater (by some margin) than the maximum average inductor average current. Estimation of the maximum average inductor current can be done using following equation:

$$I_{LMAX} = I_{OUTMAX} \cdot \frac{V_{OUT}}{V_{INMIN} \cdot \eta}$$

For example, for an output current of 2A at 12V with 90% efficiency, at least 8.9A of average current flows through the inductor at a minimum input voltage of 3.1V.

The inductor value has a direct effect on ripple current. Let the parameter ΔI_L represent the inductor peak-peak ripple current. The inductor ripple current contributes to the output current ripple that must be filtered by the output capacitor. Therefore, choosing high inductor ripple currents impacts the selection of the output capacitor. Higher values of ΔI_L lead to discontinuous mode (DCM) operation at moderate to light loads. The inductor ripple current ΔI_L decreases will higher inductance or frequency and increases will higher V_{IN} . Estimation of the inductor ripple current can be done using following equation:

$$\Delta I_L = \frac{V_{IN}}{f_{OSC} \cdot L} \left(1 - \frac{V_{IN}}{V_{OUT}} \right)$$

Accepting larger values of ΔI_L allows the use of low inductances but results in higher output voltage ripple and greater core losses. A reasonable starting point for setting ripple current is $\Delta I_L = 0.3 \sim 0.5 \cdot I_{LMAX}$. In a step-up topology, the maximum ripple current ΔI_L occurs at 50% duty cycle ($V_{IN} = 1/2 \cdot V_{OUT}$).

ELM631FA 4-switch Buck-Boost converters have been optimized to operate with an effective inductance in the range of 1 μ H to 10 μ H. Larger or smaller inductor values can be used to optimize the performance of the device for specific operating conditions.

Input capacitor selection

Place a high quality 0.1 μ F in parallel with at least a 22 μ F or higher ceramic type X5R or X7R bypass capacitor at the V_{IN} pin to power ground PGND for proper decoupling. Based on the application requirements additional bulk capacitance are needed to meet input voltage ripple, transient and EMI requirements. The value of the C_{IN} is a function of the source impedance, and in general, the higher the source impedance, the larger input capacitance. The required amount of input capacitance is also greatly affected by the duty cycle. High output current applications that also experience high duty cycles can place great demands on the input supply, both in terms of DC current and ripple current. The input capacitor voltage rating should exceed the maximum input voltage range.

Setting input under-voltage lockout (UVLO)

The EN pin voltage must be greater than 1.45V to enable ELM631FA. The device enters shutdown mode when the EN voltage is less than 0.4V. In shutdown mode, the input supply current for the device is lower than 5 μ A. When the EN pin voltage is higher than the shutdown threshold but less than 1.35V, the device is in standby mode. Adjustable input UVLO can be accomplished using the EN pin. As shown in Figure 4, a resistor divider from the

ELM631FA 28Vin up to 6A synchronous 4-switch buck-boost converter

<https://www.elm-tech.com>

V_{IN} pin to GND sets the input UVLO level. Chose the bottom UVLO resistor R_{UVLO_BOT} in the 10kΩ~200kΩ range to set the divider current at 10μA or higher. Typically select R_{UVLO_BOT}=100kΩ. The value of top resistor R_{UVLO_TOP}, depending on the desired turn-on voltage V_{START} at the V_{IN} pin, can be calculated with following equation:

$$R_{UVLO_TOP} = R_{UVLO_BOT} \cdot \left(\frac{V_{START}}{V_{EN}} - 1 \right) = 100k\Omega \cdot \left(\frac{V_{START}}{1.45V} - 1 \right)$$

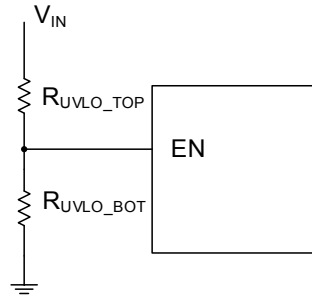

Figure 4. Input UVLO Setting

Bootstrap capacitor selection

Place a 100nF to 220nF X5R or X7R ceramic capacitor between BST and SW pins for the proper operation. This capacitor provides gate drive voltage to turn on the high-side MOSFET.

Output capacitor selection

In a step-up converter, the the output has a discontinuous current, so output capacitor C_{OUT} must be capable of reducing the output voltage ripple and filtering the high di/dt path of the supply. It is recommended to use X5R or X7R ceramic capacitors placed as close as possible to the V_{OUT} pin and power ground PGND pin. The effects of ESR (equivalent series resistance) and the bulk capacitance must be considered when choosing the right capacitor for a given output ripple voltage. The steady ripple voltage due to charging and discharging the bulk output capacitance in a single phase step-up converter is given by equation below. This value does not take into account the ESR of the output capacitor.

$$\Delta V_{OUT} = \frac{I_{OUTMAX} \cdot D_{MAX}}{C_{OUT} \cdot f_{SW}} = \frac{I_{OUTMAX} \cdot \frac{V_{OUT} - V_{INMIN}}{V_{OUT}}}{C_{OUT} \cdot f_{SW}}$$

Where C_{OUT} is the output filter capacitor.

For example: Build 5V nominal output voltage from the minimum 3.1V input supply voltage. Select switching frequency 600kHz. Choose output capacitor to get less than 50mV ripple (1% of V_{OUT}) at maximum 3A output current. The minimum output capacitor is 38μF required to limit the output voltage ripple.

$$C_{OUT} \geq \frac{I_{OUTMAX} \cdot D_{MAX}}{\Delta V_{OUT} \cdot f_{SW}} = \frac{3A \cdot \frac{5V - 3.1V}{5V}}{5V \cdot 1\% \cdot 600kHz} = 38\mu F$$

For BOOST or BUCKBOOST converter, because output capacitor current is pulsating current, multiple capacitors placed in parallel may be needed to meet the ESR and RMS current handling requirements. Ceramic capacitors have excellent low ESR characteristics but can have a DC bias effect, which will have a strong influence on the final effective capacitance. Capacitance deratings for aging, temperature and dc bias increase the minimum value required. The voltage rating must be greater than the output voltage with some tolerance for output voltage ripple and overshoot in transient conditions. For this example 4×22μF, 35V ceramic capacitors with 5mΩ of ESR are used. The 50% derated capacitance is 44μF, approximately equal to the calculated minimum.

ELM631FA 28Vin up to 6A synchronous 4-switch buck-boost converter

<https://www.elm-tech.com>

■ Application schematic

1. For 5V_{OUT}

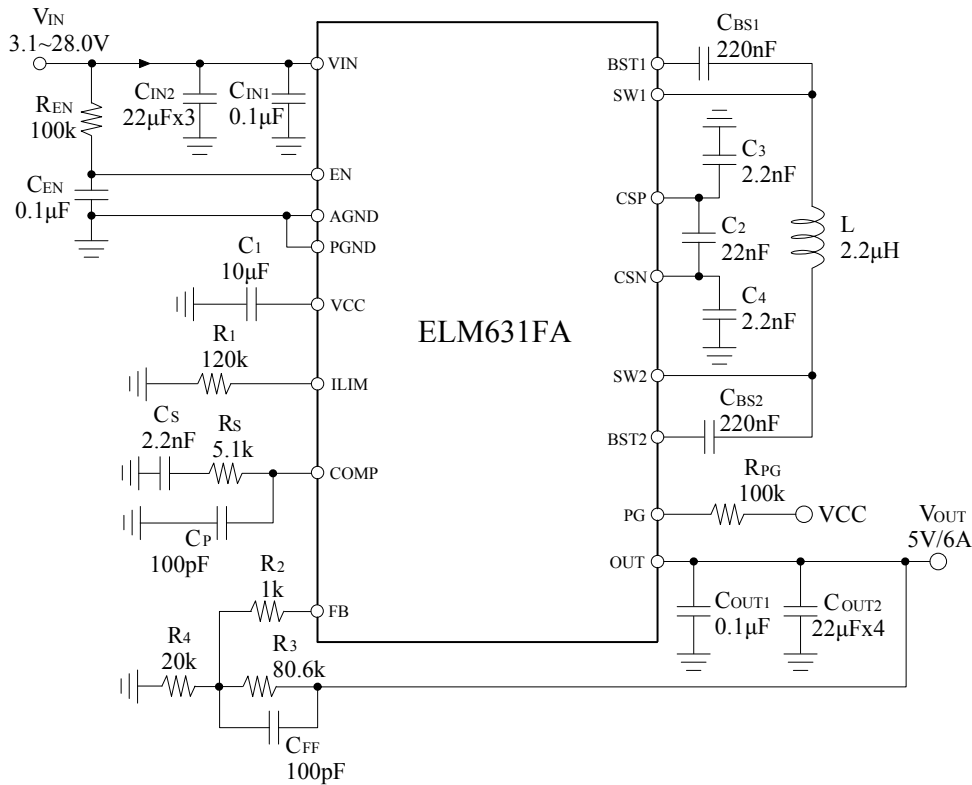

EVB BOM List

Qty	Ref	value	Description	Package
3	CIN1, COUT1 CEN	0.1µF	Ceramic capacitor, 35V, X5R	0603
7	CIN2, COUT2	22µF	Ceramic capacitor, 35V, X5R, COUT2 10V possible	0805
1	L	2.2µH	<10mΩ>10A(SAT) for 6A application	SMD
1	R1	120kΩ	Resistor, ±1%	0603
2	REN, RPG	100kΩ	Resistor, ±1%	0603
1	R2	1kΩ	Resistor, ±1%	0603
1	R3	80.6kΩ	Resistor, ±1%	0603
1	R4	20kΩ	Resistor, ±1%	0603
1	Rs	5.1kΩ	Resistor, ±1%	0603
1	Cs	2.2nF	Ceramic capacitor, 10V, X5R	0603
2	Cp, CFF	100pF	Ceramic capacitor, 10V, X5R	0603
2	CBS1, CBS2	200nF	Ceramic capacitor, 10V, X5R	0603
1	C1	10µF	Ceramic capacitor, 10V, X5R	0603
1	C2	22nF	Ceramic capacitor, 10V, X5R	0603
2	C3, C4	2.2nF	Ceramic capacitor, 10V, X5R	0603
1	Power IC	ELM631FA	4-Switch Buck-Boost converter	QFN28-5×5

ELM631FA 28Vin up to 6A synchronous 4-switch buck-boost converter

<https://www.elm-tech.com>

2. For 5 to 20V_{OUT}

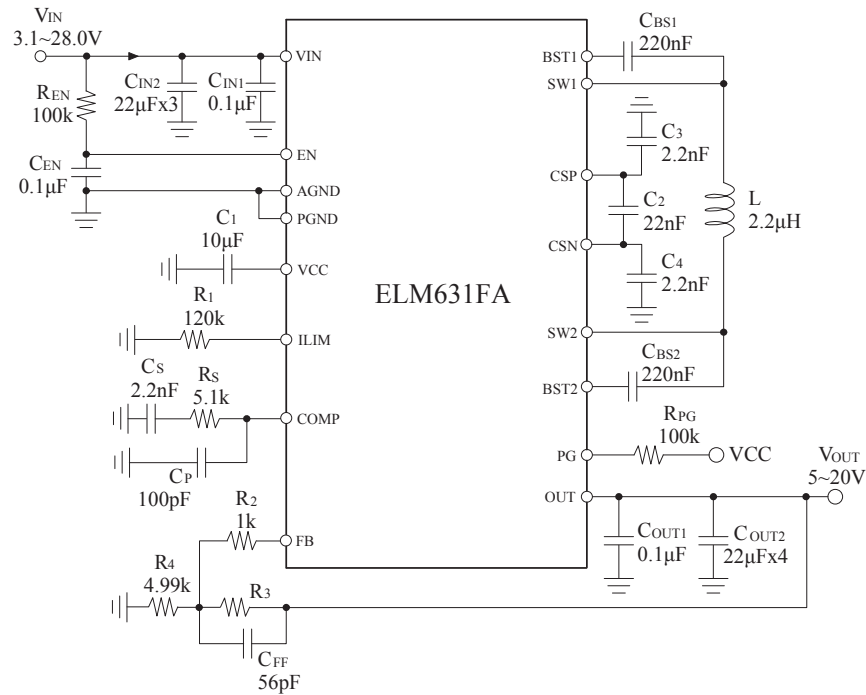

EVB BOMList

Qty	Ref	value	Description	Package										
3	C _{IN1} , C _{OUT1} C _{EN}	0.1µF	Ceramic capacitor, 35V, X5R	0603										
7	C _{IN2} , C _{OUT2}	22µF	Ceramic capacitor, 35V, X5R	0805										
1	L	2.2µH	<10mΩ>10A(SAT) for 6A application	SMD										
1	R1	120kΩ	Resistor, ±1%	0603										
2	R _{EN} , R _{PG}	100kΩ	Resistor, ±1%	0603										
1	R2	1kΩ	Resistor, ±1%	0603										
1	R3	<table border="1"> <tr> <td>V_{OUT}=5V</td> <td>20kΩ</td> </tr> <tr> <td>V_{OUT}=9V</td> <td>40.2kΩ</td> </tr> <tr> <td>V_{OUT}=12V</td> <td>55kΩ</td> </tr> <tr> <td>V_{OUT}=15V</td> <td>70.6kΩ</td> </tr> <tr> <td>V_{OUT}=20V</td> <td>95.3kΩ</td> </tr> </table>	V _{OUT} =5V	20kΩ	V _{OUT} =9V	40.2kΩ	V _{OUT} =12V	55kΩ	V _{OUT} =15V	70.6kΩ	V _{OUT} =20V	95.3kΩ	Resistor, ±1%	0603
V _{OUT} =5V	20kΩ													
V _{OUT} =9V	40.2kΩ													
V _{OUT} =12V	55kΩ													
V _{OUT} =15V	70.6kΩ													
V _{OUT} =20V	95.3kΩ													
1	R4	4.99kΩ	Resistor, ±1%	0603										
1	R _S	5.1kΩ	Resistor, ±1%	0603										
1	C _S	2.2nF	Ceramic capacitor, 10V, X5R	0603										
1	C _P	100pF	Ceramic capacitor, 10V, X5R	0603										
1	C _{FF}	56pF	Ceramic capacitor, 10V, X5R	0603										
2	C _{BS1} , C _{BS2}	220nF	Ceramic capacitor, 10V, X5R	0603										
1	C1	10µF	Ceramic capacitor, 10V, X5R	0603										
1	C2	22nF	Ceramic capacitor, 10V, X5R	0603										
2	C3, C4	2.2nF	Ceramic capacitor, 10V, X5R	0603										
1	Power IC	ELM631FA	4-Switch Buck-Boost converter	QFN28-5×5										

ELM631FA 28Vin up to 6A synchronous 4-switch buck-boost converter

<https://www.elm-tech.com>

■PCB Layout recommendation

For designing ELM631FA a Buck-Boost power supply, especially those operating at high output voltage and current application, PCB layout is a very important in design step. To prevent radiation of high frequency noise (for example, EMI), proper layout of the high frequency switching path is essential. Minimize the length and area of all traces connected to the SW pin to reducing the high frequency noise of coupling to GND plane to cause EMI or power system unstable.

Check the following layout rules:

1. Put the input capacitors GND, output capacitors GND and the PGND of ELM631FA in the same power plane to reduce impedance to avoid EMI and increase efficiency of power system.
2. The AGND and PGND kept separate and used dot short skill to avoid noise coupling to AGND to cause power system unstable as ELM631FA EV board PCB design.
3. CSP and CSN trace routing like a differential pair to shield each other to filter the common mode noise. And far away the SW trace to avoid being coupled that will cause the current limit protection circuit fault. Ensure accurate current sensing with Kelvin connections at the sense resistor or the DCR of inductor.
4. Keep the switching node (SW1/2 and PGND) and boost node (BST1/2) away from sensitive small-signal nodes.

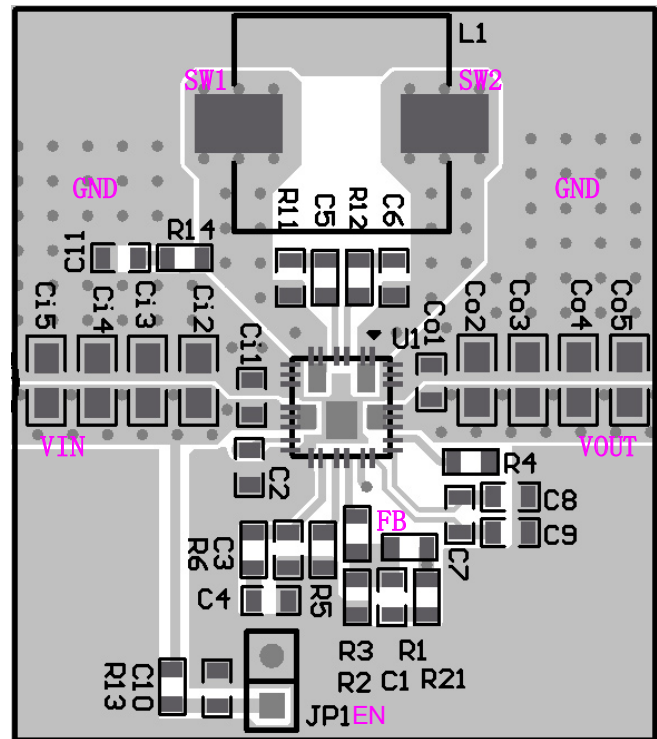
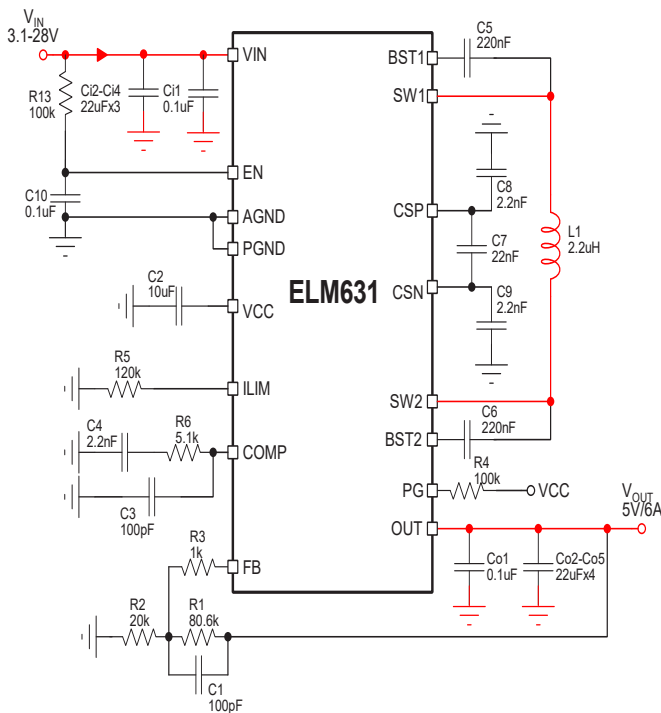

ELM631FA 28Vin up to 6A synchronous 4-switch buck-boost converter

<https://www.elm-tech.com>

■QFN28-5×5 External dimensions

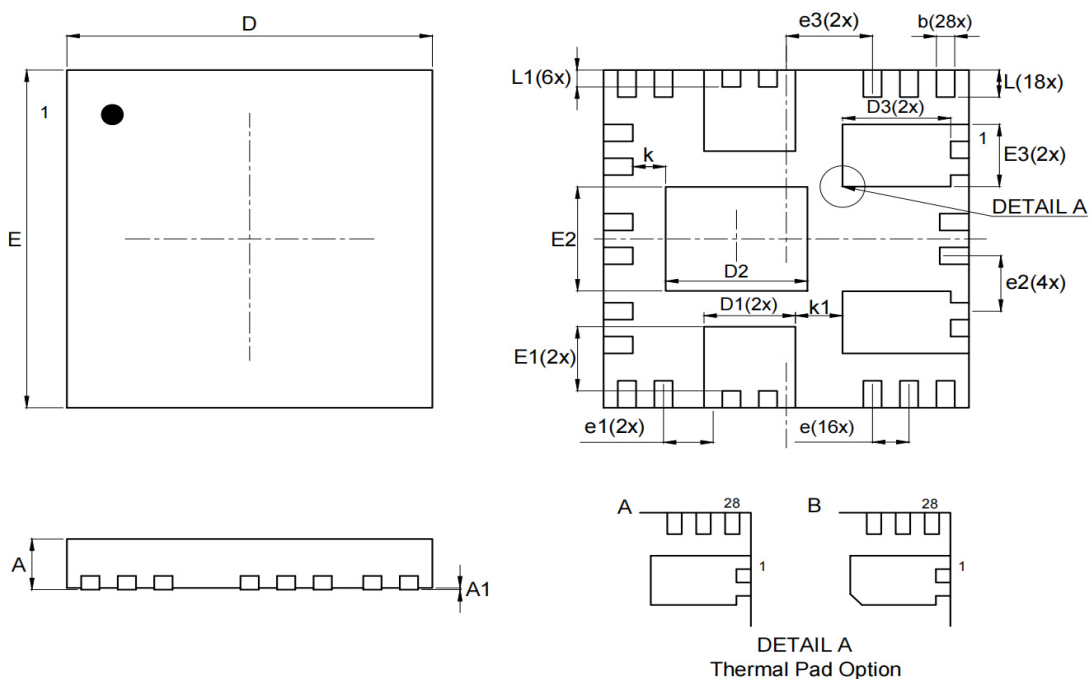

SYMBOLS	MILLIMETERS		INCHES	
	MIN.	MAX.	MIN.	MAX.
A	0.70	0.80	0.028	0.031
A1	0.00	0.05	0.000	0.002
b	0.20	0.30	0.008	0.012
D	4.90	5.10	0.193	0.201
E	4.90	5.10	0.193	0.201
L	0.35	0.45	0.014	0.018
L1	0.20	0.30	0.008	0.012
D1	1.20	1.30	0.047	0.051
D2	1.89	1.99	0.074	0.078
D3	1.43	1.53	0.056	0.060
E1	0.90	1.00	0.035	0.039
E2	1.49	1.59	0.059	0.063
E3	0.87	0.97	0.034	0.038
k	0.40	0.50	0.016	0.020
k1	0.59	0.70	0.023	0.028
e	0.50 BSC		0.020 BSC	
e1	0.68 BSC		0.027 BSC	
e2	0.82 BSC		0.032 BSC	
e3	1.18 BSC		0.046 BSC	

ELM631FA 28Vin up to 6A synchronous 4-switch buck-boost converter

<https://www.elm-tech.com>

■QFN28-5×5 Land pattern information

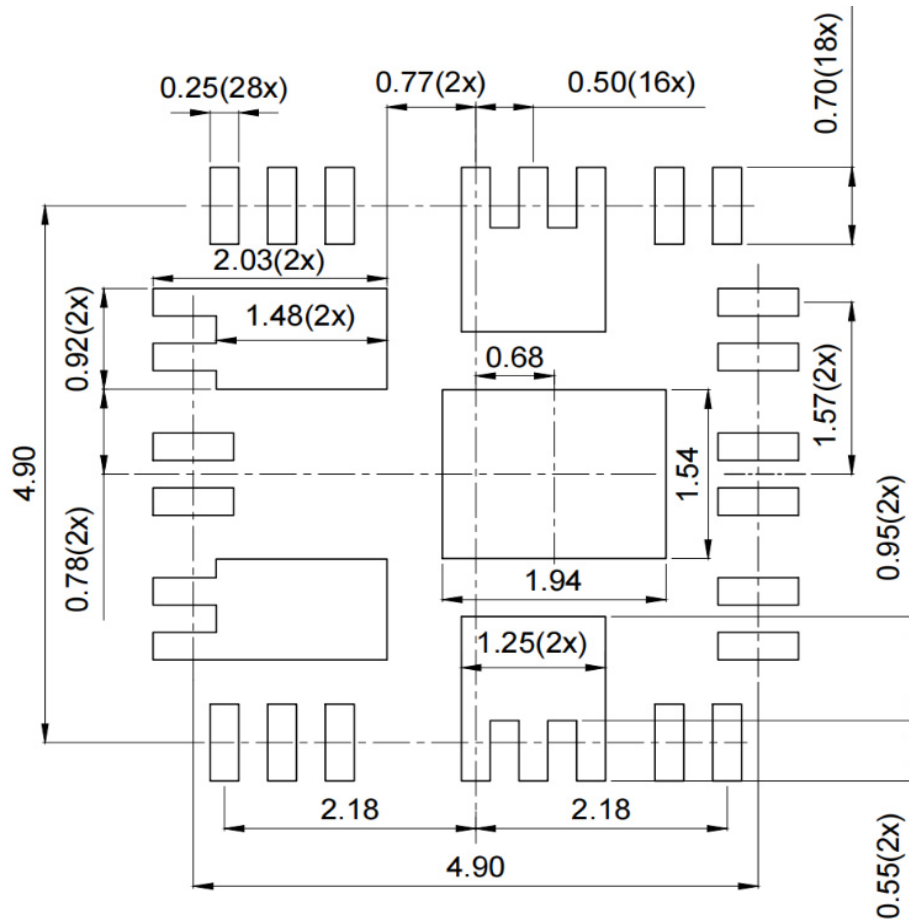

Note:

- Dimension in mm.
- For reference only.

ELM631FA 28Vin up to 6A synchronous 4-switch buck-boost converter

<https://www.elm-tech.com>

■QFN28-5×5 Carrier tape & reel dimensions

- Orientation/carrier tape information

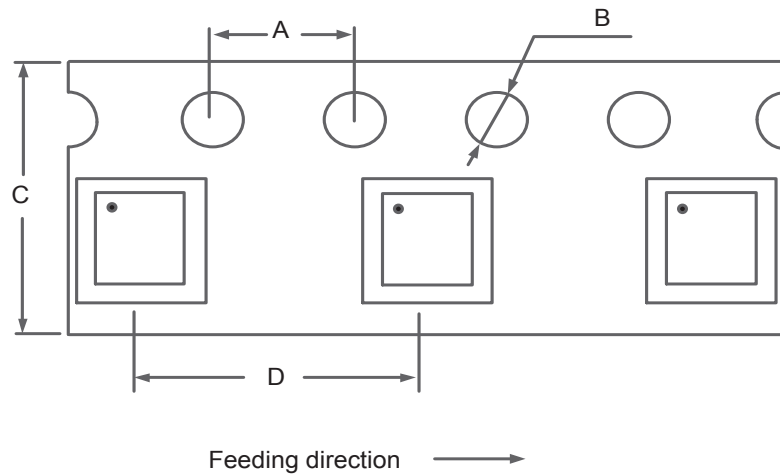

- Reel information

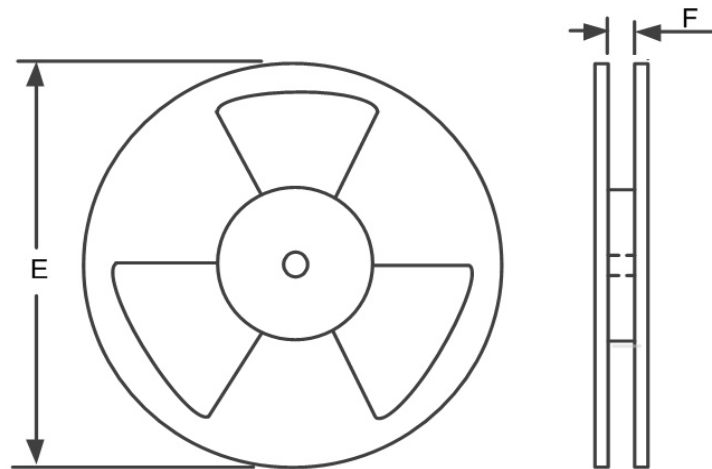

- Dimension details

PKG Type	A	B	C	D	E	F	Q'ty/Reel
QFN28-5×5	4.0 mm	1.5 mm	12.0 mm	8.0 mm	13 inches	13.0 mm	5,000