

双 N 沟道 MOSFET

ELM4DN0228FAA-N

<http://www.elm-tech.com>

■概要

ELM4DN0228FAA-N 是 N 沟道低输入电容、低工作电压、低导通电阻的大电流 MOSFET，内藏有两个 MOSFET。

■特点

- $V_{ds}=100V$
- $I_d=4A$
- $R_{ds(on)} = 68m\Omega$ ($V_{gs}=10V$)
- $R_{ds(on)} = 94m\Omega$ ($V_{gs}=4.5V$)

■绝对最大额定值

项目	记号	规格范围	单位	备注	
漏极 - 源极电压	V_{ds}	100	V		
栅极 - 源极电压	V_{gs}	± 20	V		
漏极电流 (定常) $V_{gs}=10V$	I_d	$T_a=25^\circ C$	4	A	1
		$T_a=70^\circ C$	3		
脉冲漏极电流	I_{dm}	25	A	2	
单脉冲崩溃能量	E_{as}	0.8	mJ	3	
崩溃电流	I_{as}	4	A		
容许功耗	P_d	$T_a=25^\circ C$	2.0	W	4
保存温度范围					
动作结合部温度范围	T_j	$-55 \sim 150$	$^\circ C$		

■热特性

项目	记号	典型值	最大值	单位	备注
结合部 - 环境热阻	$R_{\theta ja}$	-	85	$^\circ C/W$	1
结合部 - 环境热阻		$t \leq 10s$	-		
接合部 - 外封装热阻	$R_{\theta jc}$	-	40	$^\circ C/W$	1

■引脚配置图

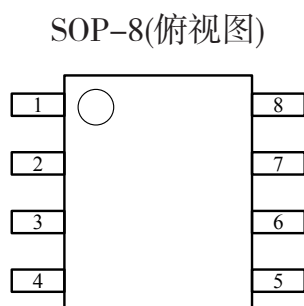

引脚编号	引脚名称
1	SOURCE1
2	GATE1
3	SOURCE2
4	GATE2
5	DRAIN2
6	DRAIN2
7	DRAIN1
8	DRAIN1

■电路图

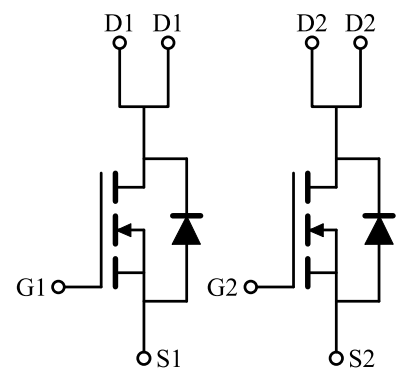

双 N 沟道 MOSFET

ELM4DN0228FAA-N

http://www.elm-tech.com

■电特性

如没有特别注明时, T_j=25℃

项目	记号	条件	最小值	典型值	最大值	单位	备注
静态特性							
漏极 - 源极击穿电压	BV _{dss}	I _d =250μA, V _{gs} =0V	100	-	-	V	
栅极接地时漏极电流	I _{dss}	V _{ds} =80V	-	-	10	μA	
		V _{gs} =0V	-	-	100		
		T _j =55℃	-	-	100		
栅极漏电流	I _{gss}	V _{ds} =0V, V _{gs} =±20V	-	-	±100	nA	
栅极阈值电压	V _{gs(th)}	V _{ds} =V _{gs} , I _d =250μA	1.5	-	2.9	V	
漏极 - 源极导通电阻	R _{ds(on)}	V _{gs} =10V, I _d =4A	-	-	68	mΩ	2
		V _{gs} =4.5V, I _d =3A	-	-	94		
正向跨导	G _{fs}	V _{ds} =5V, I _d =4A	-	14	-	S	
二极管正向压降	V _{sd}	I _s =1A, V _{gs} =0V	-	-	1.2	V	2
寄生二极管最大连续电流	I _s	V _{gs} =V _{ds} =0V, Force current	-	-	4	A	1, 5
动态特性							
输入电容	C _{iss}		-	620	-	pF	
输出电容	C _{oss}	V _{gs} =0V, V _{ds} =25V, f=1MHz	-	105	-	pF	
反馈电容	C _{rss}		-	63	-	pF	
栅极电阻	R _g	V _{ds} =0V, V _{gs} =0V, f=1MHz	-	3	-	Ω	
开关特性							
总栅极电荷 (V _{gs} =10V)	Q _g	V _{gs} =10V, V _{ds} =50V I _d =4A	-	11.9	-	nC	
栅极 - 源极电荷	Q _{gs}		-	2.6	-	nC	
栅极 - 漏极电荷	Q _{gd}		-	1.7	-	nC	
导通延迟时间	t _{d(on)}	V _{gs} =10V, V _{ds} =50V I _d =4A, R _{gen} =3Ω	-	3.8	-	ns	
导通上升时间	t _r		-	25.8	-	ns	
关闭延迟时间	t _{d(off)}		-	16.0	-	ns	
关闭下降时间	t _f		-	8.8	-	ns	
寄生二极管反向恢复时间	t _{rr}	I _f =4A, di/dt=100A/μs	-	30	-	nS	
寄生二极管反向恢复电荷	Q _{rr}		-	37	-	nC	

备注：

1. 测试数据是由安装在 1 平方英寸 20Z 铜面的 FR-4 基板上取得的；
2. 由脉冲测量的数据，脉冲宽度 ≤ 300μs，占空比 ≤ 2%；
3. EAS 的数据是指最大值。测试条件是 V_{dd} = 25V，V_{gs} = 10V，L = 0.1mH，I_{as} = 4A；
4. 功耗受 150℃ 结合部温度限制；
5. I_d 和 I_{dm} 的数据在理论上是相同的，但在实际应用中，会受总功耗的限制。

双 N 沟道 MOSFET

ELM4DN0228FAA-N

<http://www.elm-tech.com>

■ 标准特性和热特性曲线

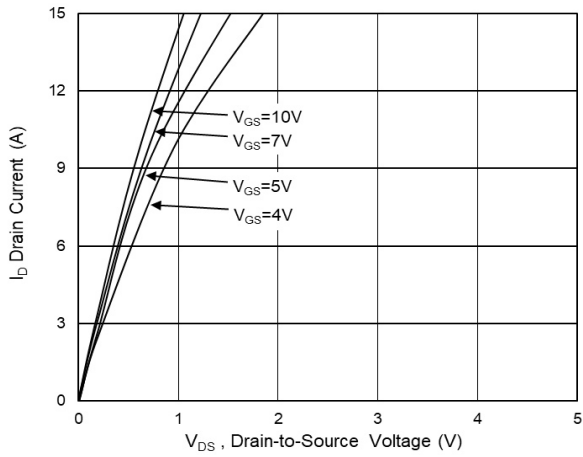

Fig.1 Typical Output Characteristics

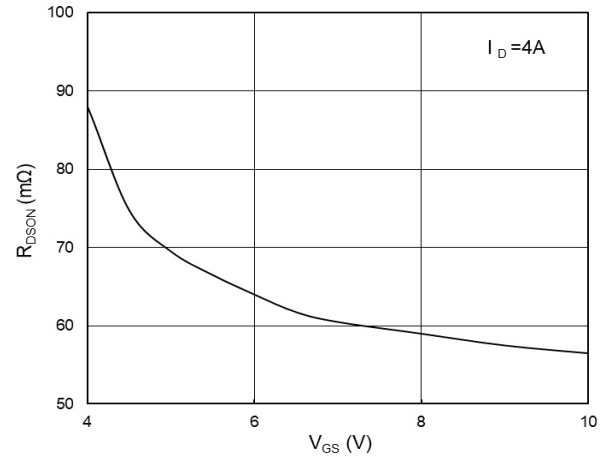

Fig.2 On-Resistance vs G-S Voltage

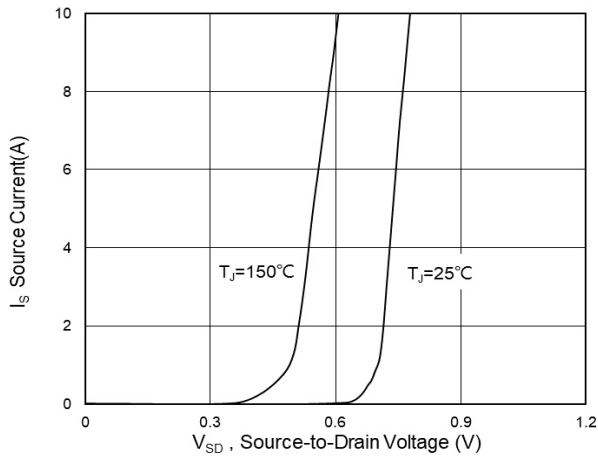

Fig.3 Source Drain Forward Characteristics

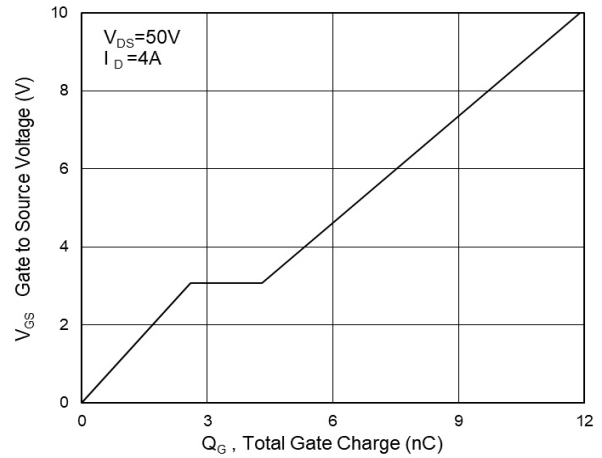

Fig.4 Gate-Charge Characteristics

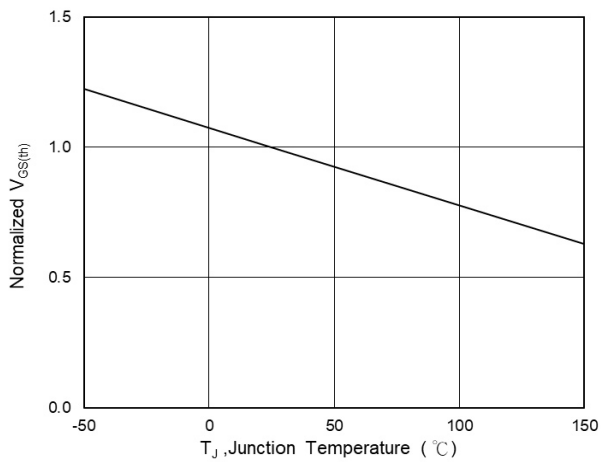

Fig.5 Normalized $V_{GS(th)}$ vs T_J

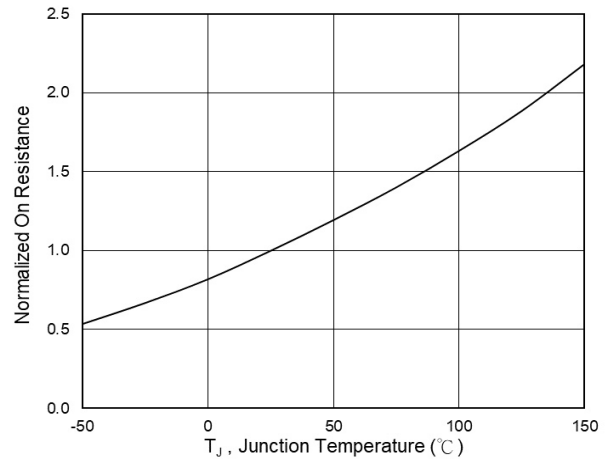

Fig.6 Normalized $R_{DS(on)}$ vs T_J

双 N 沟道 MOSFET

ELM4DN0228FAA-N

<http://www.elm-tech.com>

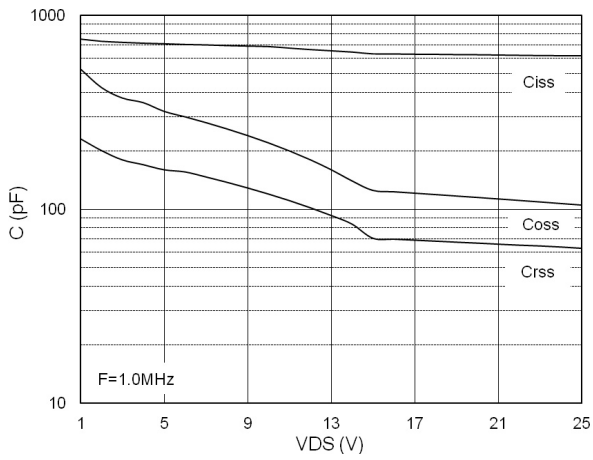

Fig.7 Capacitance

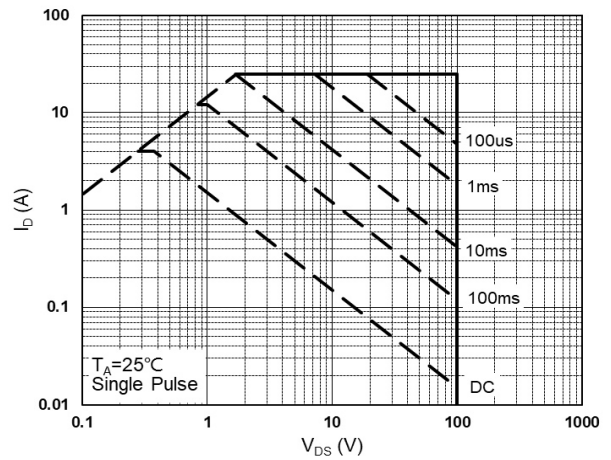

Fig.8 Safe Operating Area

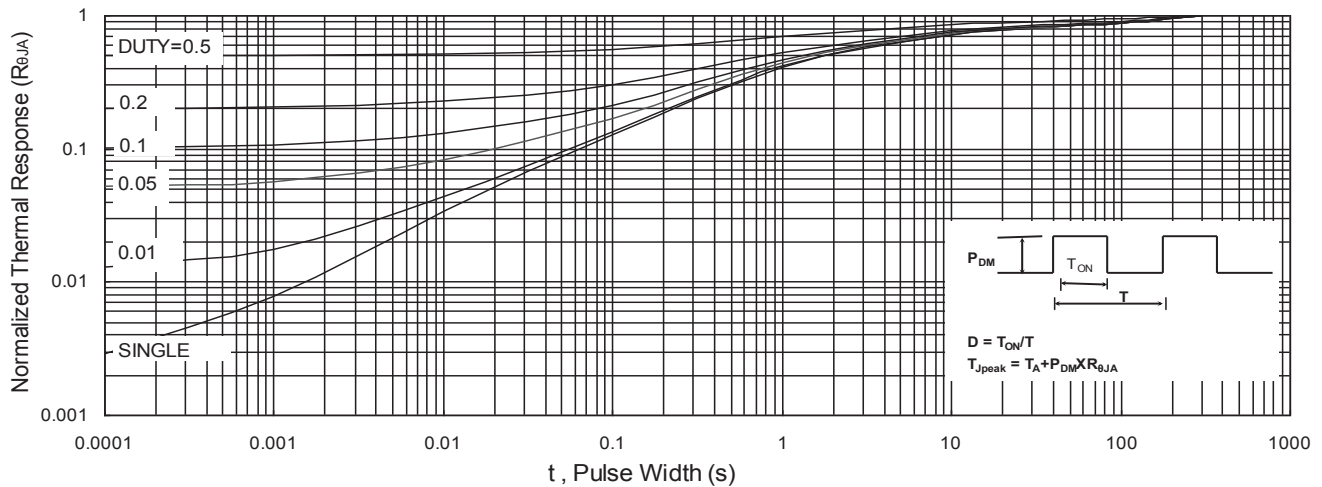

Fig.9 Normalized Maximum Transient Thermal Impedance

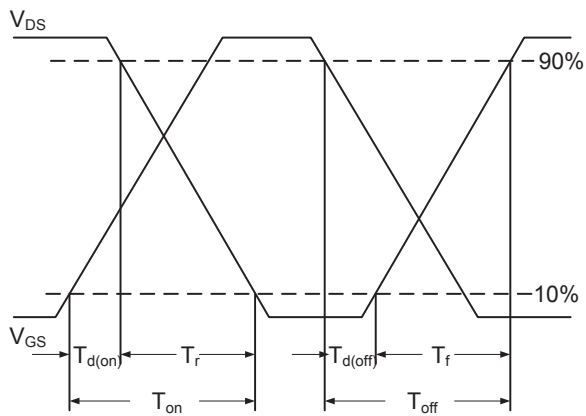

Fig.10 Switching Time Waveform

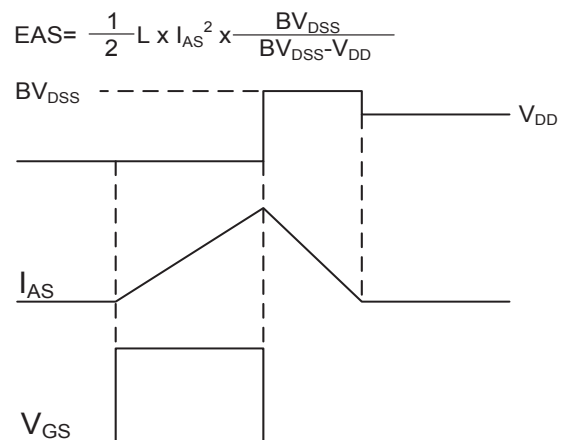

Fig.11 Unclamped Inductive Waveform