

单 N 沟道 MOSFET

ELM4N6032FDA-N

<http://www.elm-tech.com>

■概要

ELM4N6032FDA-N 是 N 沟道低输入电容，低工作电压，低导通电阻的大电流 MOSFET。

■特点

- $V_{ds}=60V$
- $I_d=75A$ ($V_{gs}=10V$)
- $R_{ds(on)} = 8.5m\Omega$ ($V_{gs}=10V$)
- $R_{ds(on)} = 12.0m\Omega$ ($V_{gs}=4.5V$)

■绝对最大额定值

项目	记号	规格范围	单位	备注	
漏极 - 源极电压	V_{ds}	60	V		
栅极 - 源极电压	V_{gs}	± 20	V		
漏极电流 (定常) ($V_{gs}=10V$)	I_d	$T_c=25^\circ C$	75	A	1
		$T_c=100^\circ C$	47		
漏极电流 (脉冲)	I_{dm}	280	A	2	
单脉冲崩溃能量	E_{as}	80	mJ	3	
崩溃电流	I_{as}	40	A		
容许功耗	P_d	$T_c=25^\circ C$	41	W	4
保存温度范围			T_{stg}	$-55 \sim +150$	$^\circ C$
结合部温度范围	T_j	$-55 \sim +150$	$^\circ C$		

■热特性

项目	记号	典型值	最大值	单位	备注
结合部 - 环境热阻	$R_{\theta ja}$	-	62.0	$^\circ C/W$	1
接合部 - 外封装热阻	$R_{\theta jc}$	-	1.4		

■引脚配置图

TO-252(俯视图)

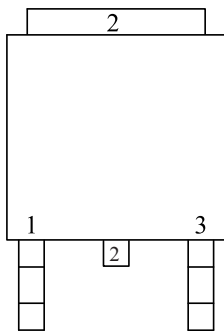

引脚编号	引脚名称
1	GATE
2	DRAIN
3	SOURCE

■电路图

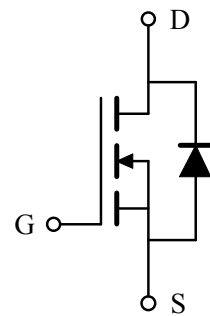

单 N 沟道 MOSFET

ELM4N6032FDA-N

<http://www.elm-tech.com>

■电特性

如没有特别注明时, $T_j=25^\circ\text{C}$

项目	记号	条件	最小值	典型值	最大值	单位	备注
静态特性							
漏极 - 源极击穿电压	BV _{dss}	V _{gs} =0V, I _d =250 μ A	60	-	-	V	
栅极接地时漏极电流	I _{dss}	V _{ds} =48V, V _{gs} =0V	-	-	1	μ A	
		V _{ds} =48V, V _{gs} =0V, T _j =55 $^\circ\text{C}$	-	-	5		
栅极漏电流	I _{gss}	V _{gs} = \pm 20V, V _{ds} =0V	-	-	\pm 100	nA	
栅极阈值电压	V _{gs(th)}	V _{gs} =V _{ds} , I _d =250 μ A	1.2	-	2.5	V	
漏极 - 源极导通电阻	R _{ds(on)}	V _{gs} =10V, I _d =20A	-	7.1	8.5	m Ω	2
		V _{gs} =4.5V, I _d =15A	-	9.5	12.0		
二极管正向压降	V _{sd}	V _{gs} =0V, I _s =1A	-	-	1.2	V	2
寄生二极管最大连续电流	I _s	V _{gs} =V _{ds} =0V, Force current	-	-	75	A	1, 5
动态特性							
输入电容	C _{iss}	V _{ds} =30V, V _{gs} =0V, f=1MHz	-	3307	-	pF	
输出电容	C _{oss}		-	201	-	pF	
反馈电容	C _{rss}		-	151	-	pF	
栅极电阻	R _g	V _{ds} =0V, V _{gs} =0V, f=1MHz	-	1.2	-	Ω	
开关特性							
总栅极电荷 (10V)	Q _g	V _{ds} =30V, V _{gs} =10V, I _d =18A	-	57.0	-	nC	
栅极 - 源极电荷	Q _{gs}		-	8.7	-	nC	
栅极 - 漏极电荷	Q _{gd}		-	14.0	-	nC	
导通延迟时间	t _{d(on)}	V _{ds} =30V, V _{gs} =10V R _{gen} =3.3 Ω , I _d =20A	-	16.2	-	ns	
导通上升时间	t _r		-	41.2	-	ns	
关闭延迟时间	t _{d(off)}		-	56.4	-	ns	
关闭下降时间	t _f		-	16.2	-	ns	
寄生二极管反向恢复时间	t _{rr}	I _f =20A, di/dt=100A/ μ s	-	22	-	nS	
寄生二极管反向恢复电荷	Q _{rr}		-	72	-	nC	

备注:

1. 测试值是安装在表面为1平方英寸2盎司铜箔的FR-4基板的状态下取得的值;
2. 脉冲测试: 脉冲宽度 \leq 300 μ 秒和占空比 \leq 2%;
3. E_{as}表示的是最大值。测试条件为V_{dd}=50V, V_{gs}=10V, L=0.1mH, I_{as}=40A;
4. 功耗受150 $^\circ\text{C}$ 结合部温度限制;
5. 数据在理论上是与I_d和I_{dm}相同的,而在实际应用中是会受总功率耗损所限制。

单 N 沟道 MOSFET

ELM4N6032FDA-N

<http://www.elm-tech.com>

■ 标准特性和热特性曲线

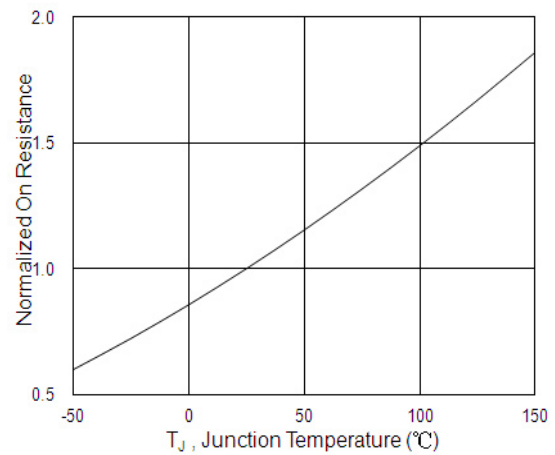
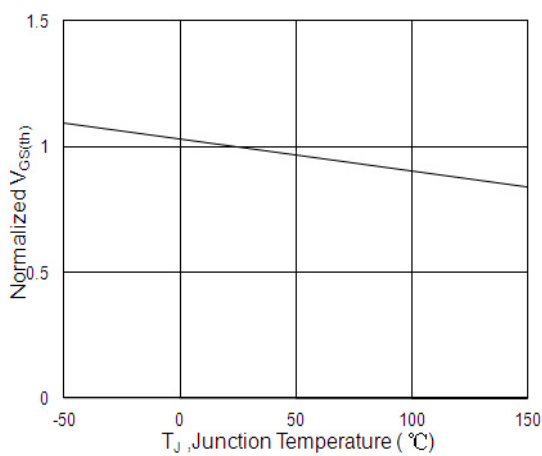
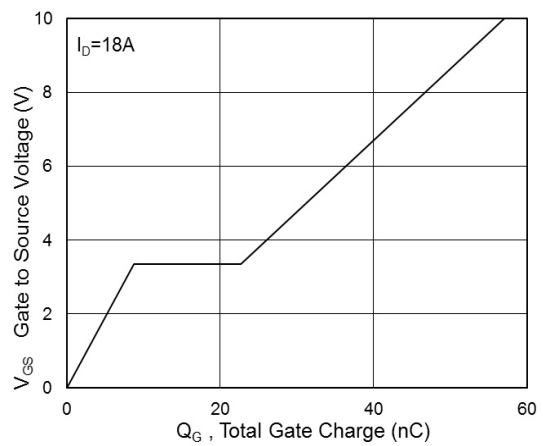
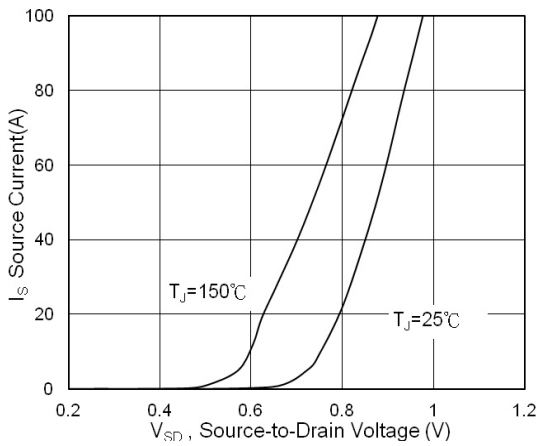
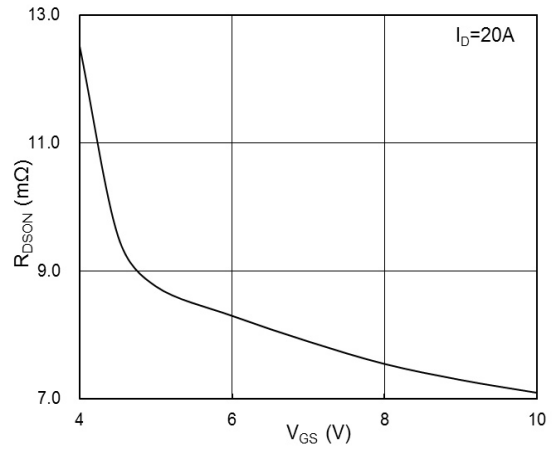
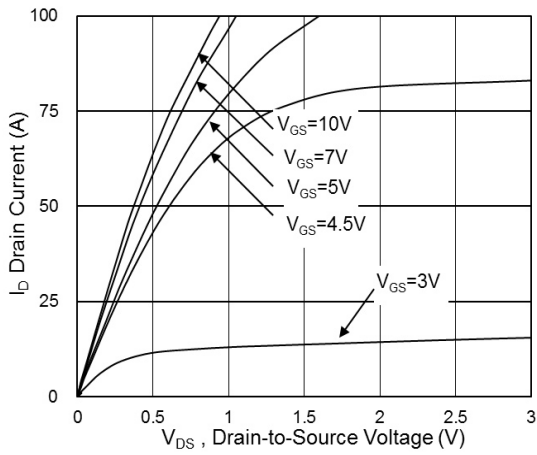

单 N 沟道 MOSFET

ELM4N6032FDA-N

<http://www.elm-tech.com>

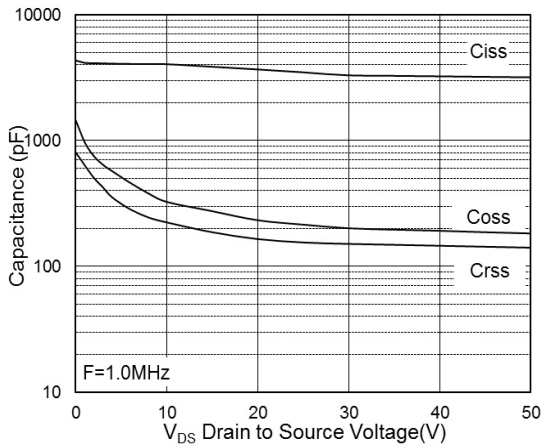

Fig.7 Capacitance

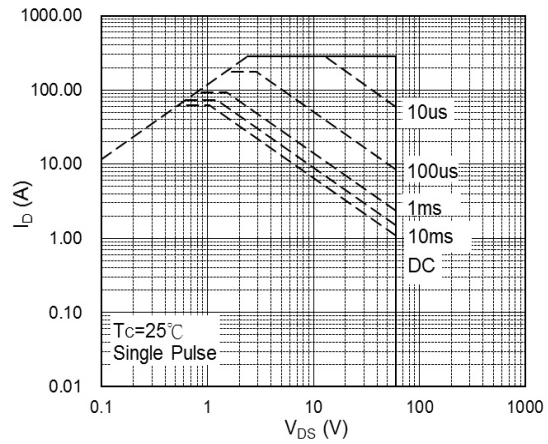

Fig.8 Safe Operating Area

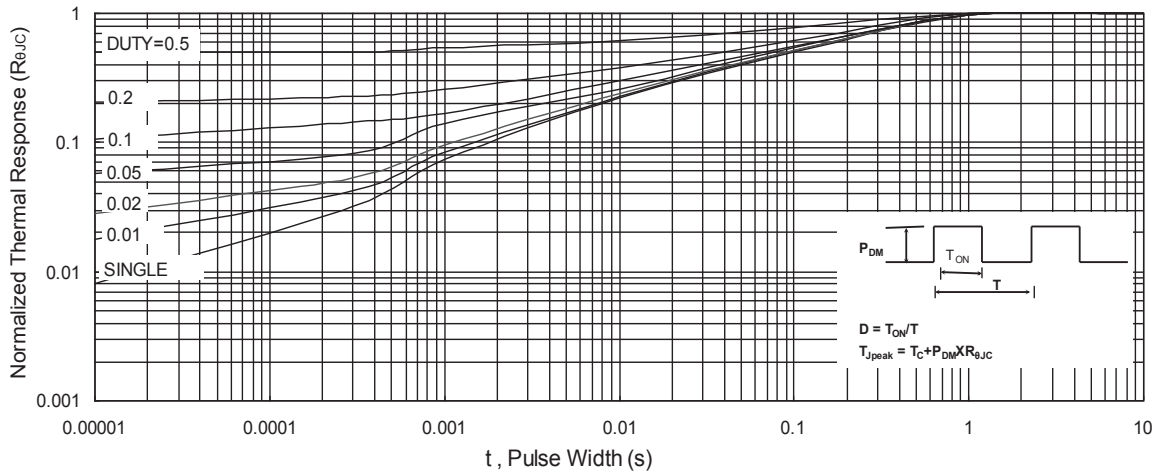

Fig.9 Normalized Maximum Transient Thermal Impedance

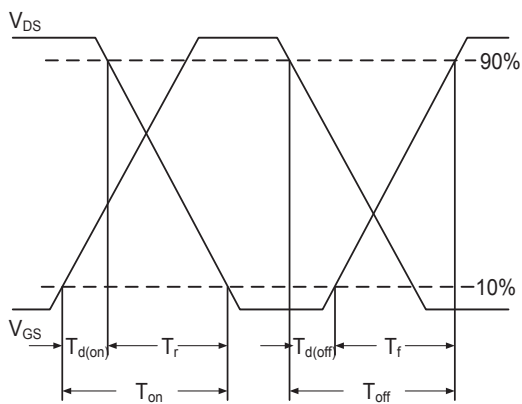

Fig.10 Switching Time Waveform

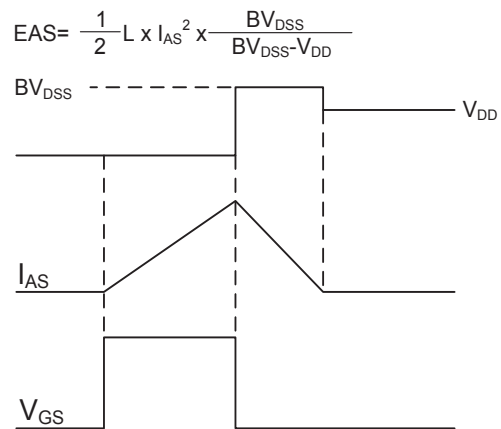

Fig.11 Unclamped Inductive Switching Waveform