

双 P 沟道 MOSFET

ELM51023EA-S

<http://www.elm-tech.com>

■概要

ELM51023EA-S 是 P 沟道低输入电容、低工作电压、低导通电阻的大电流 MOSFET，内藏有两个 MOSFET。另外，此芯片还内藏 ESD 保护电路。

■特点

- $V_{ds}=20V$
- $I_d=0.45A$
- $R_{ds(on)} = 800m\Omega$ ($V_{gs}=4.5V$)
- $R_{ds(on)} = 950m\Omega$ ($V_{gs}=2.5V$)
- $R_{ds(on)} = 1250m\Omega$ ($V_{gs}=1.8V$)
- ESD 保护

■绝对最大额定值

如没有特别注明时, $T_a=25^\circ C$

项目	记号	规格范围	单位	
漏极 - 源极电压	V_{ds}	-20	V	
栅极 - 源极电压	V_{gs}	± 12	V	
漏极电流 (定常) ($T_j=150^\circ C$)	I_d	$T_a=25^\circ C$	-0.45	A
		$T_a=70^\circ C$	-0.25	A
漏极电流 (脉冲)	I_{dm}	-1.0	A	
容许功耗	P_d	$T_c=25^\circ C$	0.27	W
		$T_c=70^\circ C$	0.16	W
结合部温度及保存温度范围	T_j, T_{stg}	-55 ~ 150	$^\circ C$	

■引脚配置图

SOT-563(俯视图)

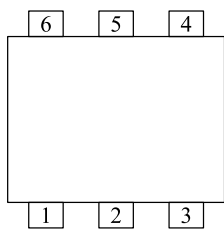

引脚编号	引脚名称
1	SOURCE1
2	GATE1
3	DRAIN2
4	SOURCE2
5	GATE2
6	DRAIN1

■电路图

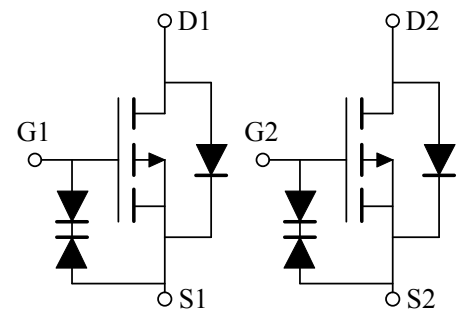

双 P 沟道 MOSFET

ELM51023EA-S

<http://www.elm-tech.com>

■电特性

如没有特别注明时, Ta=25℃

项目	记号	条件	最小值	典型值	最大值	单位
静态特性						
漏极 - 源极击穿电压	BV _{dss}	I _d =-250μA, V _{gs} =0V	-20			V
栅极接地时漏极电流	I _{dss}	V _{ds} =-20V, V _{gs} =0V Ta=85℃			-5	μA
					-10	
栅极漏电流	I _{gss}	V _{ds} =0V, V _{gs} =±12V			±1	mA
栅极阈值电压	V _{gs(th)}	V _{ds} =V _{gs} , I _d =-250μA	-0.4		-1.0	V
导通时漏极电流	I _{d(on)}	V _{gs} =-4.5V, V _{ds} ≥-5V	-0.7			A
漏极 - 源极导通电阻	R _{ds(on)}	V _{gs} =-4.5V, I _d =-0.6A		550	800	mΩ
		V _{gs} =-2.5V, I _d =-0.5A		700	950	
		V _{gs} =-1.8V, I _d =-0.4A		1000	1250	
正向跨导	G _{fs}	V _{ds} =-10V, I _d =-0.4A		1		S
二极管正向压降	V _{sd}	I _s =-0.15A, V _{gs} =0V		-0.65	-1.20	V
寄生二极管最大连续电流	I _s				-0.3	A
动态特性						
输入电容	C _{iss}	V _{gs} =0V, V _{ds} =-10V, f=1MHz		70	100	pF
输出电容	C _{oss}			20		pF
反馈电容	C _{rss}			10		pF
开关特性						
总栅极电荷	Q _g	V _{gs} =-4.5V, V _{ds} =-10V I _d ≐-0.25A		1.0	1.3	nC
栅极 - 源极电荷	Q _{gs}			0.1		nC
栅极 - 漏极电荷	Q _{gd}			0.3		nC
导通延迟时间	t _{d(on)}	V _{gs} =-4.5V, V _{ds} =-10V		10	15	ns
导通上升时间	t _r			10	15	ns
关闭延迟时间	t _{d(off)}	RL=30Ω, I _d ≐-0.2A		40	60	ns
关闭下降时间	t _f	R _{gen} =10Ω		30	50	ns

双 P 沟道 MOSFET

ELM51023EA-S

<http://www.elm-tech.com>

■ 标准特性和热特性曲线

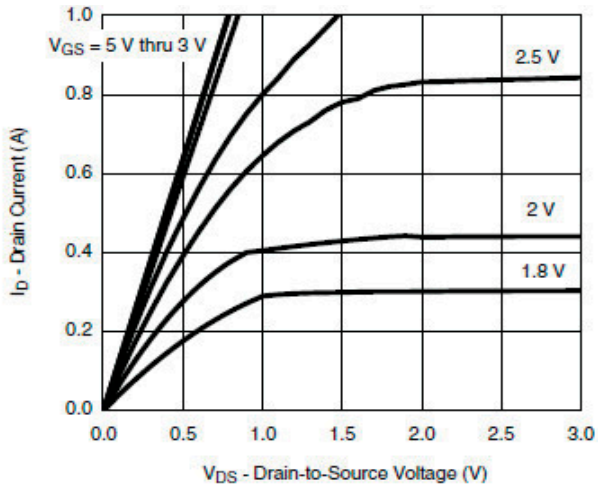

Output Characteristics

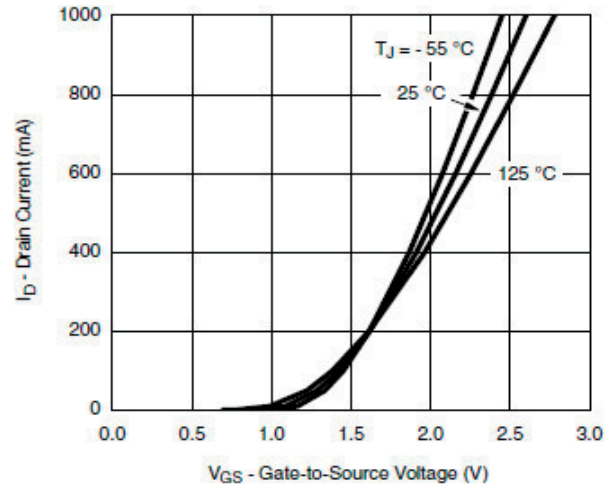

Transfer Characteristics

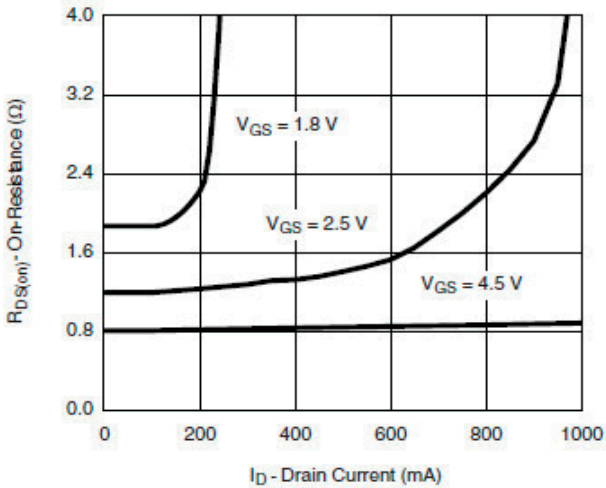

On-Resistance vs. Drain Current

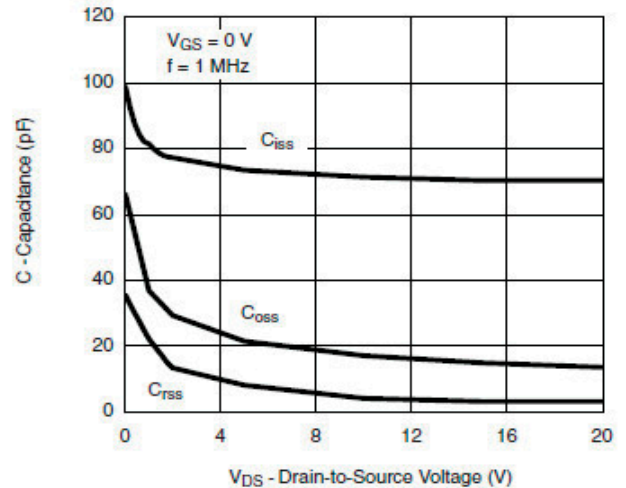

Capacitance

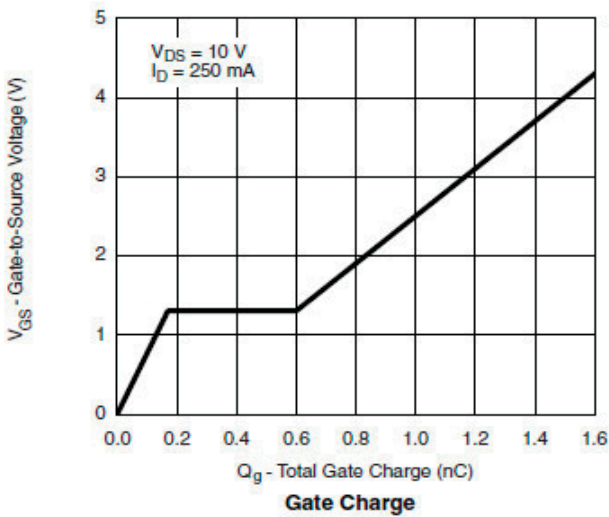

Gate Charge

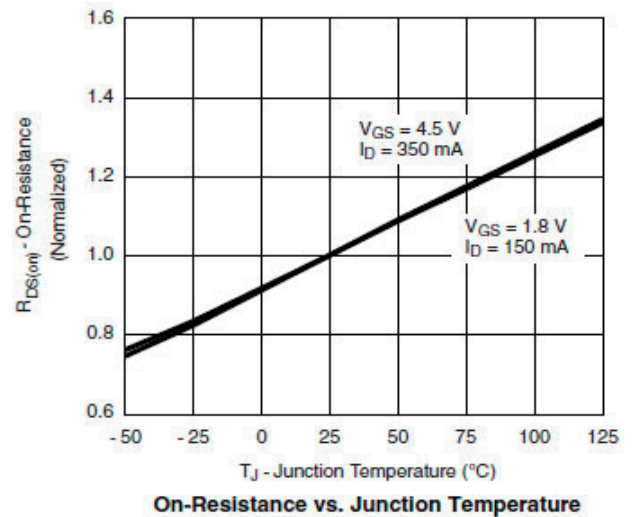

On-Resistance vs. Junction Temperature

双 P 沟道 MOSFET

ELM51023EA-S

http://www.elm-tech.com

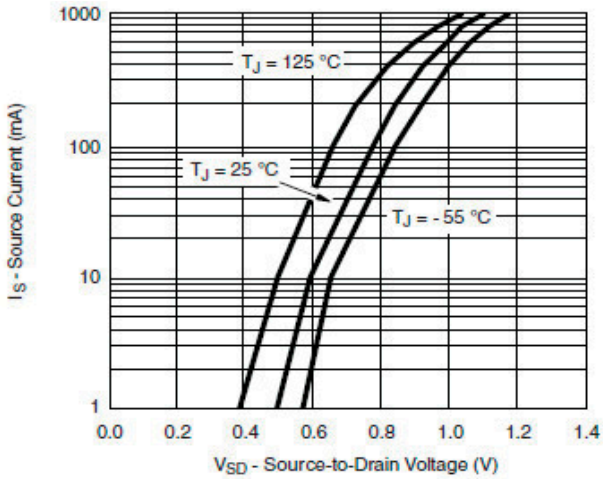

Source-Drain Diode Forward Voltage

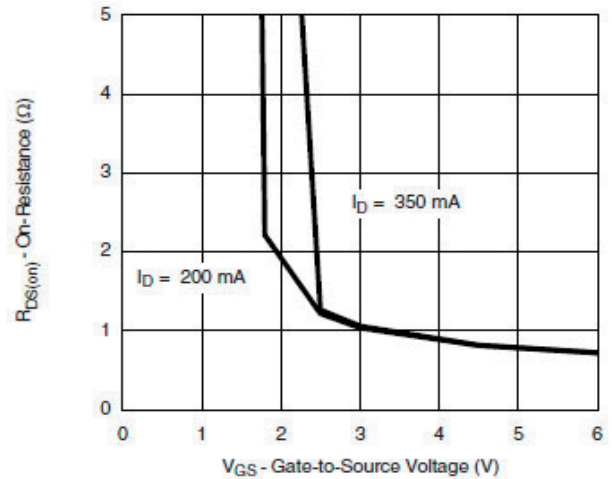

On-Resistance vs. Gate-to-Source Voltage

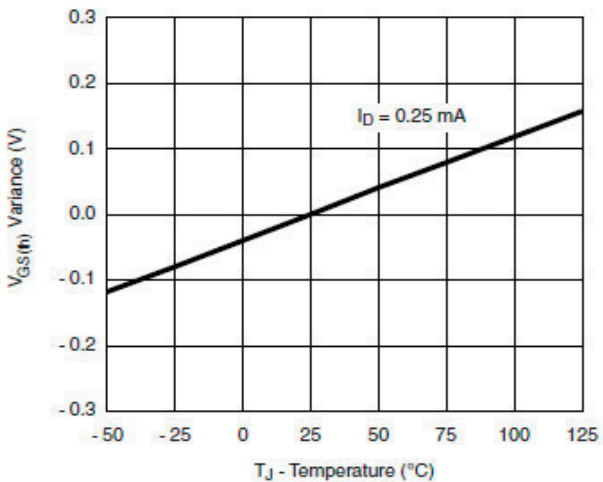

Threshold Voltage Variance vs. Temperature

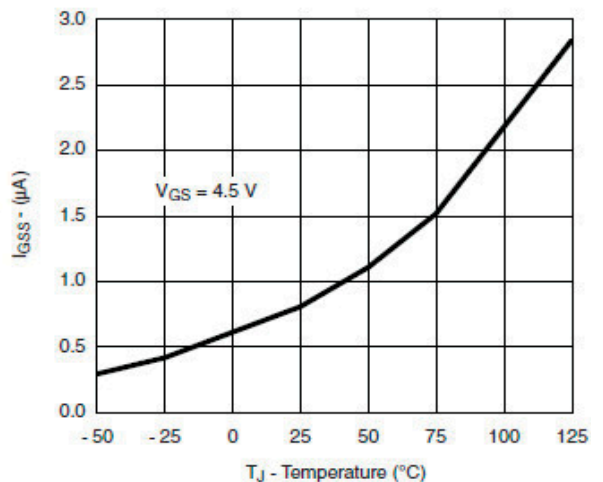

I_{GSS} vs. Temperature

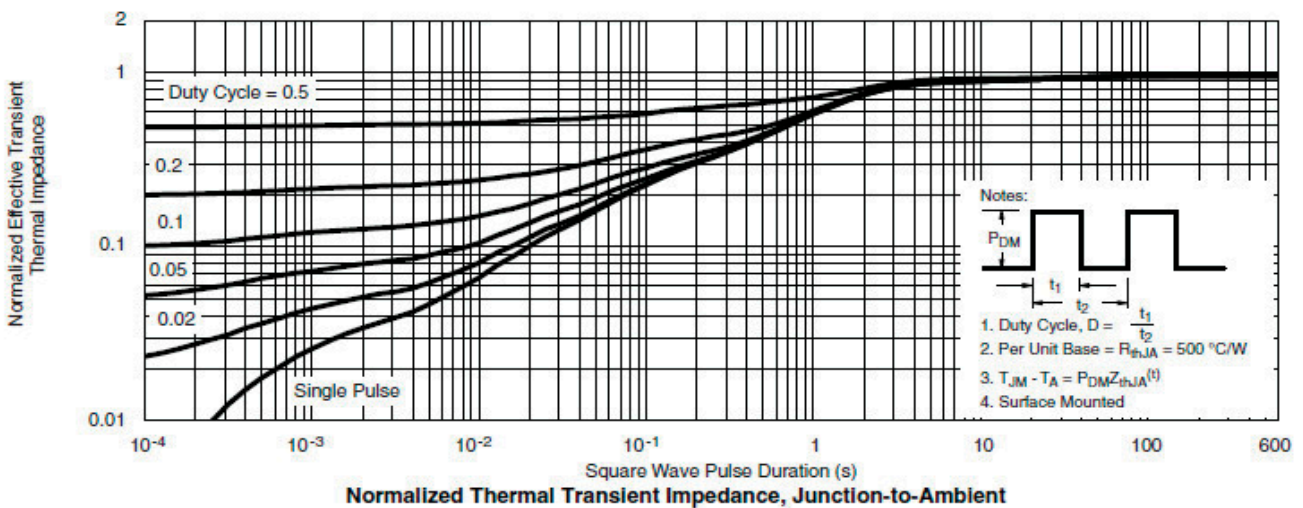

双 P 沟道 MOSFET

ELM51023EA-S

<http://www.elm-tech.com>

■ 试验电路图和测试波形图

Gate Charge Test Circuit & Waveform

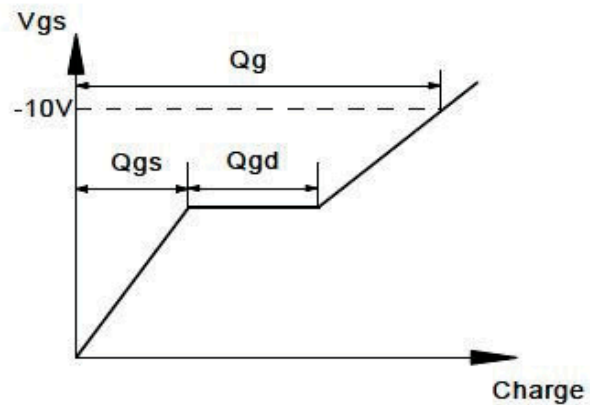
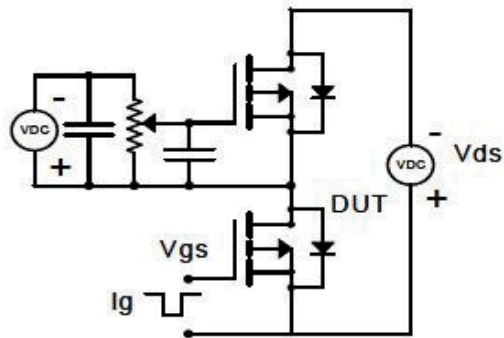

Resistive Switching Test Circuit & Waveforms

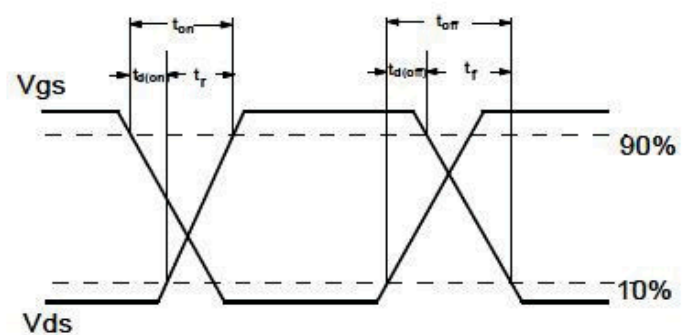
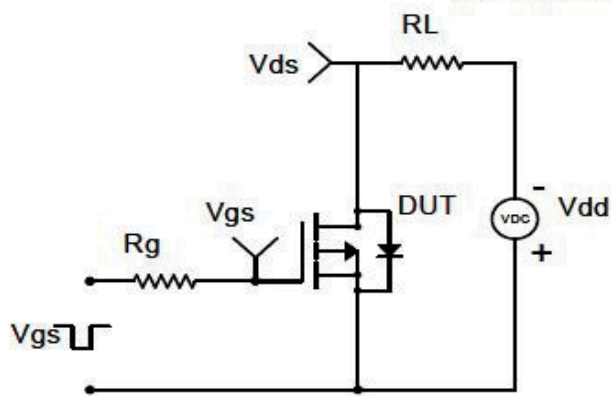

Diode Recovery Test Circuit & Waveforms

