

# 封装、卷带、卷带方向

SOT-89 (1,000 个 / 卷)

ELM0431AxA

<http://www.elm-tech.com>

## ■SOT-89 尺寸

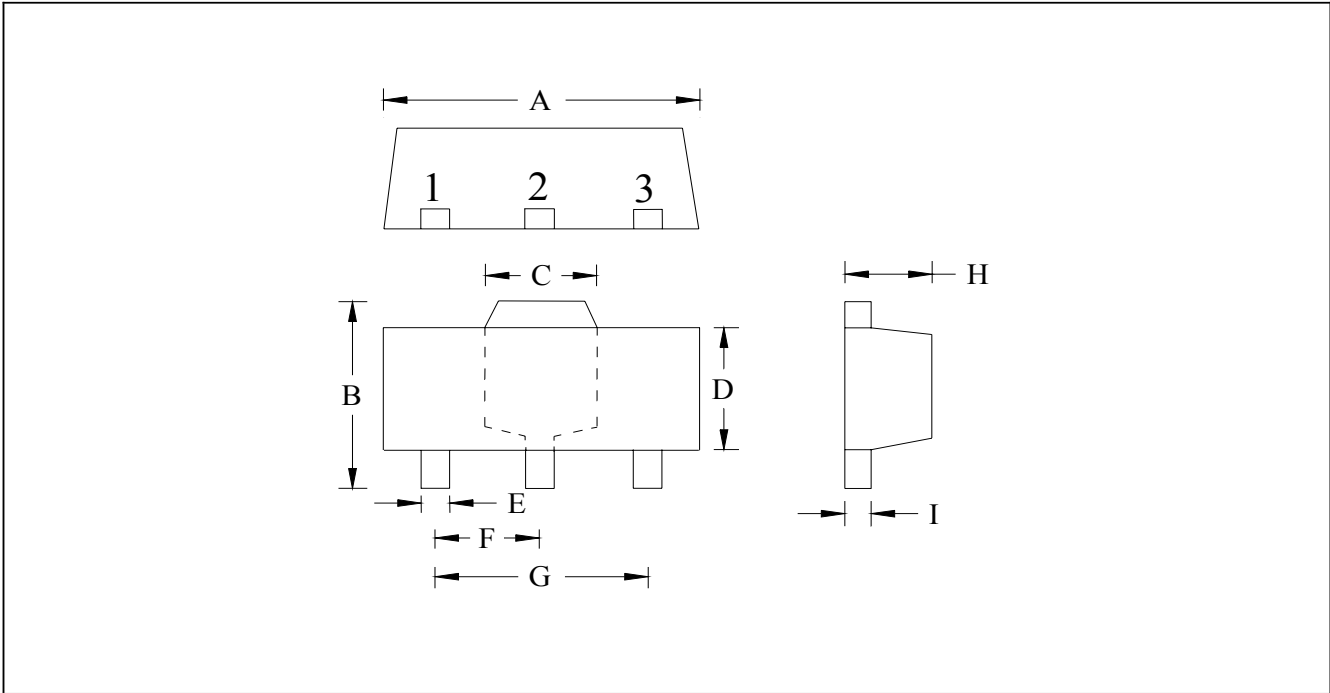

DIM	Inches		Millimeters		DIM	Inches		Millimeters	
	Min.	Max.	Min.	Max.		Min.	Max.	Min.	Max.
A	0.1732	0.1811	4.40	4.60	F	0.0591	TYP	1.50	TYP
B	0.1551	0.1673	3.94	4.25	G	0.1181	TYP	3.00	TYP
C	0.0610	REF	1.55	REF	H	0.0551	0.0630	1.40	1.60
D	0.0906	0.1024	2.30	2.60	I	0.0138	0.0173	0.35	0.44
E	0.0126	0.0205	0.32	0.52					

Notes: 1. Controlling dimension: millimeters.

2. Maximum lead thickness includes lead finish thickness, and minimum lead thickness is the minimum thickness of base material.

### Material:

- Lead: Pure tin plated.
- Mold Compound: Epoxy resin family, flammability solid burning class: UL94V-0.

# 封装、卷带、卷带方向

SOT-89 (1,000 个 / 卷)

ELM0431AxA

<http://www.elm-tech.com>

## ■卷带和载带尺寸

### • 卷盘

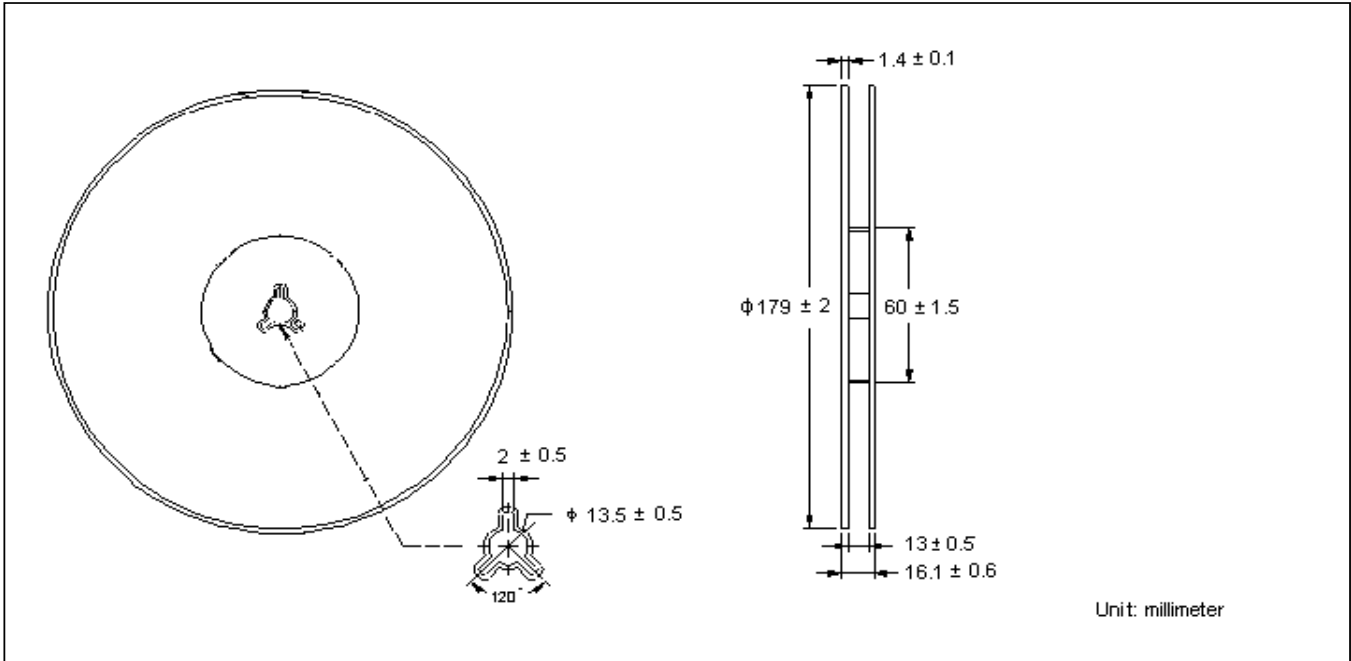

### • 载带

