



# **GD25LE256D**

# **DATASHEET**

## Contents

<b>1. FEATURES</b> .....	<b>4</b>
<b>2. GENERAL DESCRIPTION</b> .....	<b>5</b>
<b>3. MEMORY ORGANIZATION</b> .....	<b>7</b>
<b>4. DEVICE OPERATION</b> .....	<b>8</b>
<b>5. DATA PROTECTION</b> .....	<b>9</b>
<b>6. STATUS REGISTER</b> .....	<b>11</b>
<b>7. COMMANDS DESCRIPTION</b> .....	<b>13</b>
7.1.    ENABLE 4-BYTE MODE (B7H).....	18
7.2.    DISABLE 4-BYTE MODE (E9H) .....	19
7.3.    WRITE ENABLE (WREN) (06H).....	20
7.4.    WRITE DISABLE (WRDI) (04H) .....	21
7.5.    WRITE ENABLE FOR VOLATILE STATUS REGISTER (50H) .....	22
7.6.    READ STATUS REGISTER (RDSR) (05H OR 35H OR 15H) .....	23
7.7.    WRITE STATUS REGISTER (WRSR) (01H) .....	24
7.8.    READ DATA BYTES (READ) (03H).....	25
7.9.    READ DATA BYTES AT HIGHER SPEED (FAST READ) (0BH).....	26
7.10.   DUAL OUTPUT FAST READ (3BH).....	28
7.11.   QUAD OUTPUT FAST READ (6BH) .....	29
7.12.   DUAL I/O FAST READ (BBH) .....	30
7.13.   QUAD I/O FAST READ (EBH) .....	32
7.14.   QUAD I/O WORD FAST READ (E7H) .....	35
7.15.   SET BURST WITH WRAP (77H) .....	36
7.16.   PAGE PROGRAM (PP) (02H).....	37
7.17.   QUAD PAGE PROGRAM (32H).....	39
7.18.   SECTOR ERASE (SE) (20H).....	40
7.19.   32KB BLOCK ERASE (BE) (52H) .....	41
7.20.   64KB BLOCK ERASE (BE) (D8H).....	42
7.21.   CHIP ERASE (CE) (60/C7H).....	43
7.22.   DEEP POWER-DOWN (DP) (B9H).....	44
7.23.   RELEASE FROM DEEP POWER-DOWN AND READ DEVICE ID (RDI) (ABH) .....	45
7.24.   READ MANUFACTURE ID/ DEVICE ID (REMS) (90H) .....	47
7.25.   READ MANUFACTURE ID/ DEVICE ID DUAL I/O (92H) .....	48
7.26.   READ MANUFACTURE ID/ DEVICE ID QUAD I/O (94H).....	49
7.27.   READ IDENTIFICATION (RDID) (9FH).....	50
7.28.   PROGRAM/ERASE SUSPEND (PES) (75H) .....	51
7.29.   PROGRAM/ERASE RESUME (PER) (7AH) .....	52
7.30.   READ UNIQUE ID (4BH).....	53
7.31.   ERASE SECURITY REGISTERS (44H) .....	54
7.32.   PROGRAM SECURITY REGISTERS (42H).....	55



---

7.33.	READ SECURITY REGISTERS (48H) .....	56
7.34.	SET READ PARAMETERS (COH) .....	57
7.35.	BURST READ WITH WRAP (0CH) .....	58
7.36.	BURST READ WITH WRAP FOR LOWER 128MB (8CH) .....	59
7.37.	BURST READ WITH WRAP FOR HIGHER 128MB (8DH) .....	60
7.38.	ENABLE QPI (38H).....	61
7.39.	DISABLE QPI (FFH) .....	61
7.40.	ENABLE RESET (66H) AND RESET (99H) .....	62
7.41.	READ SERIAL FLASH DISCOVERABLE PARAMETER (5AH).....	63
<b>8.</b>	<b>ELECTRICAL CHARACTERISTICS .....</b>	<b>68</b>
8.1.	POWER-ON TIMING .....	68
8.2.	INITIAL DELIVERY STATE .....	68
8.3.	ABSOLUTE MAXIMUM RATINGS .....	68
8.4.	CAPACITANCE MEASUREMENT CONDITIONS .....	69
8.5.	DC CHARACTERISTICS.....	70
8.6.	AC CHARACTERISTICS.....	73
<b>9.</b>	<b>ORDERING INFORMATION.....</b>	<b>77</b>
9.1.	VALID PART NUMBERS .....	78
<b>10.</b>	<b>PACKAGE INFORMATION .....</b>	<b>79</b>
10.1.	PACKAGE SOP16 300MIL .....	79
10.2.	PACKAGE WSON8 (6*5MM).....	80
10.3.	PACKAGE WSON8 (8*6MM).....	81
<b>11.</b>	<b>REVISION HISTORY .....</b>	<b>82</b>

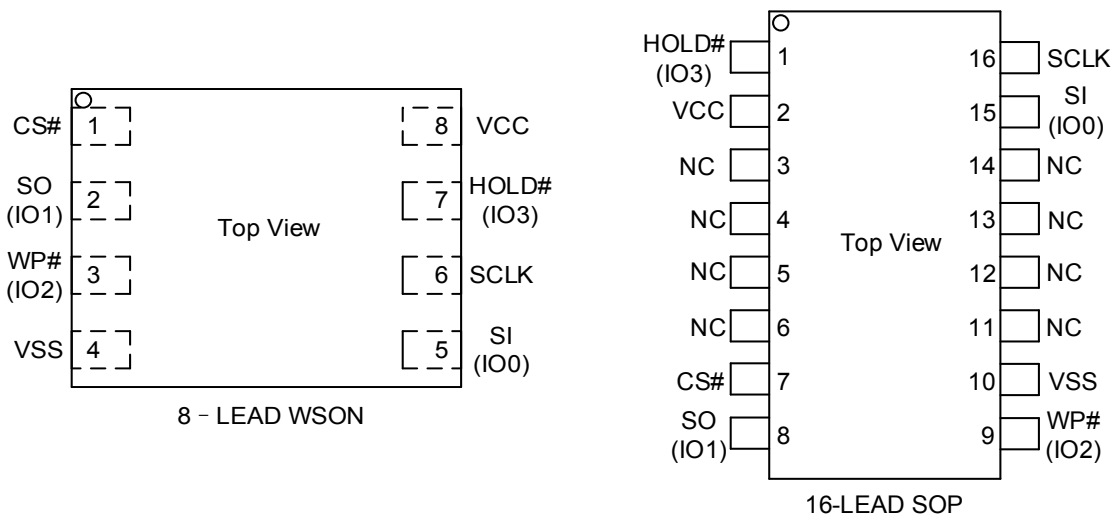
## 1. FEATURES

- ◆ 256M-bit Serial Flash
  - 32M-byte
  - 256 bytes per programmable page
- ◆ Standard, Dual, Quad SPI, QPI
  - Standard SPI: SCLK, CS#, SI, SO, WP#, HOLD#
  - Dual SPI: SCLK, CS#, IO0, IO1, WP#, HOLD#
  - Quad SPI: SCLK, CS#, IO0, IO1, IO2, IO3
  - QPI: SCLK, CS#, IO0, IO1, IO2, IO3
- ◆ High Speed Clock Frequency
  - 120MHz for fast read with 30PF load
  - Dual I/O Data transfer up to 240Mbits/s
  - Quad I/O Data transfer up to 480Mbits/s
  - QPI Mode Data transfer up to 480Mbits/s
- ◆ Allows XIP (execute in place) Operation
  - Continuous Read With 8/16/32/64-byte Wrap
- ◆ Software/Hardware Write Protection
  - Write protect all/portion of memory via software
  - Enable/Disable protection with WP# Pin
  - Top/Bottom Block protection
- ◆ Fast Program/Erase Speed
  - Page Program time: 0.5ms typical
  - Sector Erase time: 70ms typical
  - Block Erase time: 0.16/0.3s typical
  - Chip Erase time: 100s typical
- ◆ Flexible Architecture
  - Uniform Sector of 4K-byte
  - Uniform Block of 32/64K-byte
  - Erase/Program Suspend/Resume
- ◆ Low Power Consumption
  - 70uA typical stand-by current
  - 0.4uA typical power-down current
- ◆ Advanced Security Features
  - 128-bit Unique ID for each device
  - 2x1024-Byte Security Registers With OTP Lock
- ◆ Single Power Supply Voltage
  - Full voltage range: 1.65~2.0V
- ◆ Endurance and Data Retention
  - Minimum 100,000 Program/Erase Cycles
  - 20-year data retention typical

## 2. GENERAL DESCRIPTION

The GD25LE256D (256M-bit) Serial flash supports the standard Serial Peripheral Interface (SPI), and supports the Dual/Quad SPI and QPI mode: Serial Clock, Chip Select, Serial Data I/O0 (SI), I/O1 (SO), I/O2 (WP#), and I/O3 (HOLD#). The Dual I/O data is transferred with speed of 240Mbits/s and the Quad I/O & Quad output data is transferred with speed of 480Mbits/s.

### CONNECTION DIAGRAM



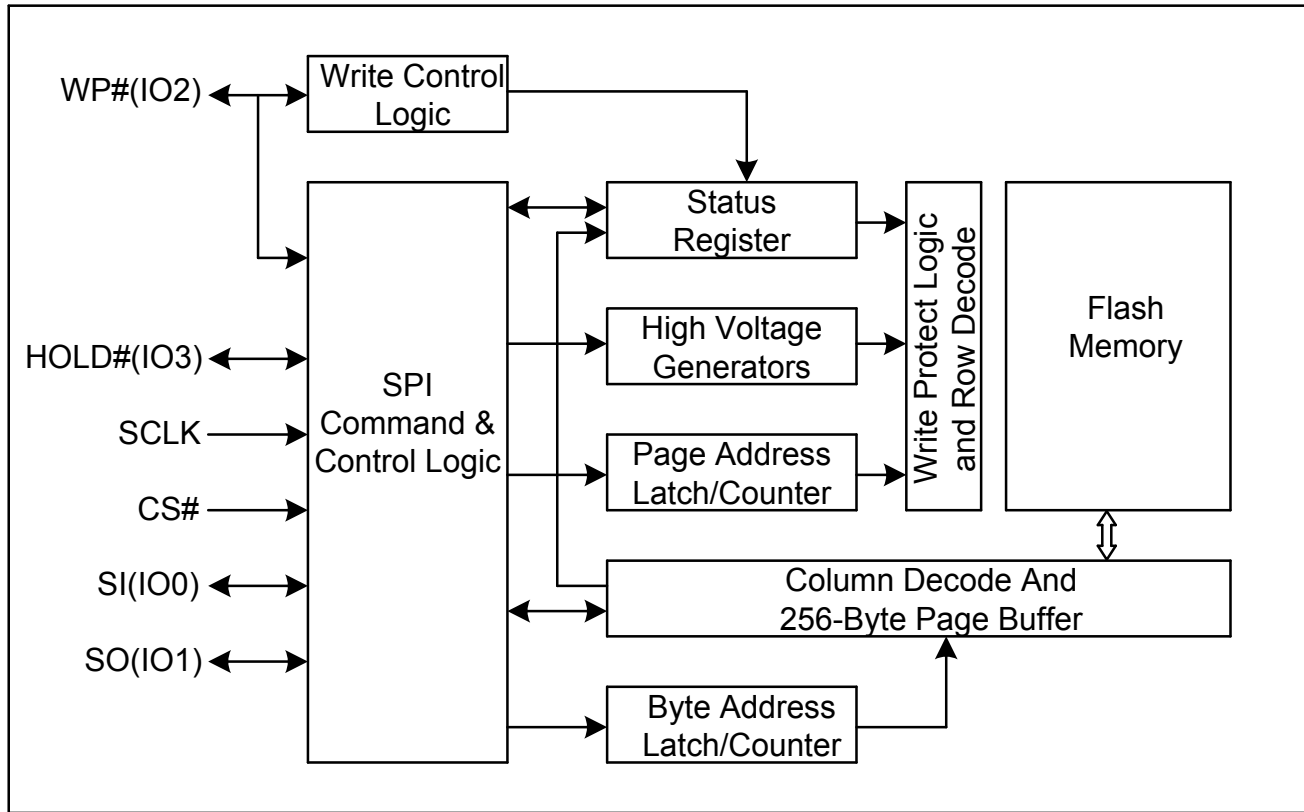
### PIN DESCRIPTION

Pin Name	I/O	Description
CS#	I	Chip Select Input
SO (IO1)	I/O	Data Output (Data Input Output 1)
WP# (IO2)	I/O	Write Protect Input (Data Input Output 2)
VSS		Ground
SI (IO0)	I/O	Data Input (Data Input Output 0)
SCLK	I	Serial Clock Input
HOLD# (IO3)	I/O	Hold Input (Data Input Output 3)
VCC		Power Supply

Note:

1. CS# must be driven high if chip is not selected. Please don't leave CS# floating any time after power is on.
2. The NC pin/ball is not connected to any internal signal. It is OK to connect it to the system ground (GND) or leave it floating.

**BLOCK DIAGRAM**



### 3. MEMORY ORGANIZATION

#### GD25LE256D

Each device has	Each block has	Each sector has	Each page has	
32M	64/32K	4K	256	bytes
128K	256/128	16	-	pages
8192	16/8	-	-	sectors
512/1024	-	-	-	blocks

#### UNIFORM BLOCK SECTOR ARCHITECTURE

##### GD25LE256D 64K Bytes Block Sector Architecture

Block	Sector	Address range	
511	8191	1FFF000H	1FFFFFFFH
	.....	.....	.....
	8176	1FF0000H	1FF0FFFH
510	8175	1FEF000H	1FEFFFFH
	.....	.....	.....
	8160	1FE0000H	1FE0FFFH
.....	.....	.....	.....
	.....	.....	.....
	.....	.....	.....
.....	.....	.....	.....
	.....	.....	.....
	.....	.....	.....
2	47	02F000H	02FFFFH
	.....	.....	.....
	32	020000H	020FFFH
1	31	01F000H	01FFFFH
	.....	.....	.....
	16	010000H	010FFFH
0	15	00F000H	00FFFFH
	.....	.....	.....
	0	000000H	000FFFH

## 4. DEVICE OPERATION

### SPI Mode

#### Standard SPI

The GD25LE256D features a serial peripheral interface on 4 signals bus: Serial Clock (SCLK), Chip Select (CS#), Serial Data Input (SI) and Serial Data Output (SO). Both SPI bus mode 0 and 3 are supported. Input data is latched on the rising edge of SCLK and data shifts out on the falling edge of SCLK.

#### Dual SPI

The GD25LE256D supports Dual SPI operation when using the “Dual Output Fast Read” and “Dual I/O Fast Read” (3BH and BBH) commands. These commands allow data to be transferred to or from the device at twice the rate of the standard SPI. When using the Dual SPI command the SI and SO pins become bidirectional I/O pins: IO0 and IO1.

#### Quad SPI

The GD25LE256D supports Quad SPI operation when using the “Quad Output Fast Read”, “Quad I/O Fast Read”, “Quad I/O Word Fast Read”, “Quad Page Program” (6BH, EBH, E7H, 32H) commands. These commands allow data to be transferred to or from the device at four times the rate of the standard SPI. When using the Quad SPI command the SI and SO pins become bidirectional I/O pins: IO0 and IO1, and WP# and HOLD# pins become IO2 and IO3. Quad SPI commands require the non-volatile Quad Enable bit (QE) in Status Register to be set.

#### QPI

The GD25LE256D supports Quad Peripheral Interface (QPI) operations only when the device is switched from Standard/Dual/Quad SPI mode to QPI mode using the “Enable the QPI (38H)” command. The QPI mode utilizes all four IO pins to input the command code. Standard/Dual/Quad SPI mode and QPI mode are exclusive. Only one mode can be active at any given times. “Enable the QPI (38H)” and “Disable the QPI (FFH)” commands are used to switch between these two modes. Upon power-up and after software reset using “Reset (99H)” command, the default state of the device is Standard/Dual/Quad SPI mode. The QPI mode requires the non-volatile Quad Enable bit (QE) in Status Register to be set.

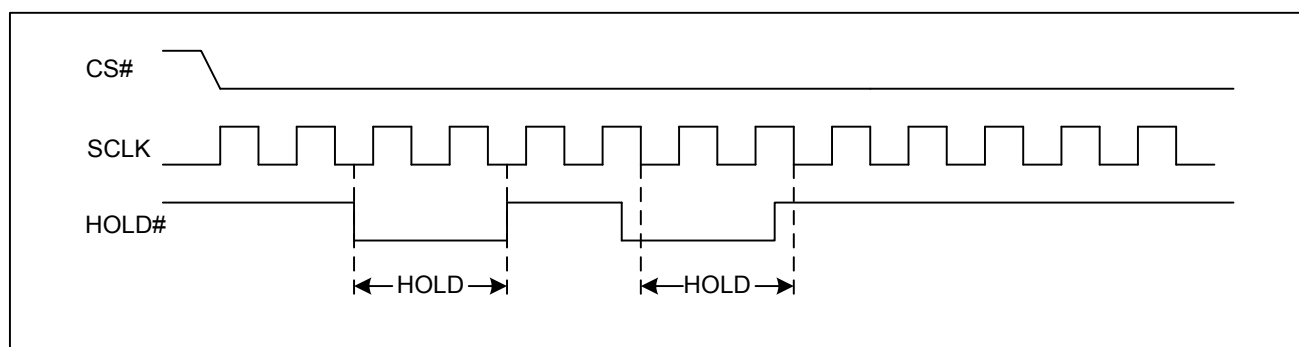
#### Hold

The HOLD# signal goes low to stop any serial communications with the device, but doesn't stop the operation of write status register, programming, or erasing in progress.

The operation of HOLD, need CS# keep low, and starts on falling edge of the HOLD# signal, with SCLK signal being low (if SCLK is not being low, HOLD operation will not start until SCLK being low). The HOLD condition ends on rising edge of HOLD# signal with SCLK being low (If SCLK is not being low, HOLD operation will not end until SCLK being low).

The SO is high impedance, both SI and SCLK don't care during the HOLD operation, if CS# drives high during HOLD operation, it will reset the internal logic of the device. To re-start communication with chip, the HOLD# must be at high and then CS# must be at low.

**Figure1. Hold Condition**





## 5. DATA PROTECTION

The GD25LE256D provide the following data protection methods:

- ◆ Write Enable (WREN) command: The WREN command is set the Write Enable Latch bit (WEL). The WEL bit will return to reset by the following situation:
  - Power-Up
  - Write Disable (WRDI)
  - Write Status Register (WRSR)
  - Page Program (PP)
  - Sector Erase (SE) / Block Erase (BE) / Chip Erase (CE)
  - Erase Security Registers / Program Security Registers
  - Software reset (66H+99H)
- ◆ Software Protection Mode: The Block Protect (BP4, BP3, BP2, BP1, and BP0) bits define the section of the memory array that can be read but not change.
- ◆ Hardware Protection Mode: WP# goes low to protect the BP0~BP4 bits and SRP0~1 bits.
- ◆ Deep Power-Down Mode: In Deep Power-Down Mode, all commands are ignored except the Release from Deep Power-Down Mode command and reset command (66H+99H).

**Table1. GD25LE256D Protected area size (CMP=0)**

Status Register Content					Memory Content			
BP4	BP3	BP2	BP1	BP0	Blocks	Addresses	Density	Portion
X	X	0	0	0	NONE	NONE	NONE	NONE
0	0	0	0	1	504 to 511	1F80000H-1FFFFFFFH	512KB	Upper 1/64
0	0	0	1	0	495 to 511	1F00000H-1FFFFFFFH	1MB	Upper 1/32
0	0	0	1	1	479 to 511	1E00000H-1FFFFFFFH	2MB	Upper 1/16
0	0	1	0	0	447 to 511	1C00000H-1FFFFFFFH	4MB	Upper 1/8
0	0	1	0	1	384 to 511	1800000H-1FFFFFFFH	8MB	Upper 1/4
0	0	1	1	0	256 to 511	1000000H-1FFFFFFFH	16MB	Upper 1/2
0	1	0	0	1	0 to 7	000000H-07FFFFFFH	512KB	Lower 1/64
0	1	0	1	0	0 to 15	000000H-0FFFFFFFH	1MB	Lower 1/32
0	1	0	1	1	0 to 31	000000H-1FFFFFFFH	2MB	Lower 1/16
0	1	1	0	0	0 to 63	000000H-3FFFFFFFH	4MB	Lower 1/8
0	1	1	0	1	0 to 127	000000H-7FFFFFFFH	8MB	Lower 1/4
0	1	1	1	0	0 to 255	000000H-0FFFFFFFH	16MB	Lower 1/2
X	X	1	1	1	0 to 511	000000H-1FFFFFFFH	32MB	ALL
1	0	0	0	1	511	1FFF000H-1FFFFFFFH	4KB	Top Block
1	0	0	1	0	511	1FFE000H-1FFFFFFFH	8KB	Top Block
1	0	0	1	1	511	1FFC000H-1FFFFFFFH	16KB	Top Block
1	0	1	0	X	511	1FF8000H-1FFFFFFFH	32KB	Top Block
1	0	1	1	0	511	1FF8000H-1FFFFFFFH	32KB	Top Block
1	1	0	0	1	0	000000H-000FFFFH	4KB	Bottom Block
1	1	0	1	0	0	000000H-001FFFFH	8KB	Bottom Block
1	1	0	1	1	0	000000H-003FFFFH	16KB	Bottom Block



# 1.8V Uniform Sector Dual and Quad Serial Flash

## GD25LE256D

1	1	1	0	X	0	000000H-007FFFFH	32KB	Bottom Block
1	1	1	1	0	0	000000H-007FFFFH	32KB	Bottom Block

Table1a. GD25LE256D Protected area size (CMP=1)

Status Register Content					Memory Content			
BP4	BP3	BP2	BP1	BP0	Blocks	Addresses	Density	Portion
X	X	0	0	0	0 to 511	000000H-1FFFFFFFH	ALL	ALL
0	0	0	0	1	0 to 503	000000H-1F7FFFFFH	32256KB	Lower 63/64
0	0	0	1	0	0 to 494	000000H-1EFFFFFFFH	31MB	Lower 31/32
0	0	0	1	1	0 to 478	000000H-1DFFFFFFFH	30MB	Lower 15/16
0	0	1	0	0	0 to 446	000000H-1BFFFFFFFH	28MB	Lower 7/8
0	0	1	0	1	0 to 383	000000H-17FFFFFFFH	24MB	Lower 3/4
0	0	1	1	0	0 to 254	000000H-0FFFFFFFH	16MB	Lower 1/2
0	1	0	0	1	8 to 511	080000H-1FFFFFFFH	32256KB	Upper 63/64
0	1	0	1	0	16 to 511	100000H-1FFFFFFFH	31MB	Upper 31/32
0	1	0	1	1	32 to 511	200000H-1FFFFFFFH	30MB	Upper 15/16
0	1	1	0	0	64 to 511	400000H-1FFFFFFFH	28MB	Upper 7/8
0	1	1	0	1	128 to 511	800000H-1FFFFFFFH	24MB	Upper 3/4
0	1	1	1	0	256 to 511	1000000H-1FFFFFFFH	16MB	Upper 1/2
X	X	1	1	1	NONE	NONE	NONE	NONE
1	0	0	0	1	0 to 511	000000H-1FFEFFFFH	32764KB	L-4095/4096
1	0	0	1	0	0 to 511	000000H-1FFDFFFFH	32760KB	L-2047/2048
1	0	0	1	1	0 to 511	000000H-1FFBFFFFH	32752KB	L-1023/1024
1	0	1	0	X	0 to 511	000000H-1FF7FFFFH	32736KB	L-511/512
1	0	1	1	0	0 to 511	000000H-1FF7FFFFH	32736KB	L-511/512
1	1	0	0	1	0 to 511	001000H-1FFFFFFFH	32764KB	U-4095/4096
1	1	0	1	0	0 to 511	002000H-1FFFFFFFH	32760KB	U-2047/2048
1	1	0	1	1	0 to 511	004000H-1FFFFFFFH	32752KB	U-1023/1024
1	1	1	0	X	0 to 511	008000H-1FFFFFFFH	32736KB	U-511/512
1	1	1	1	0	0 to 511	008000H-1FFFFFFFH	32736KB	U-511/512

## 6. Status Register

<b>S15</b>	<b>S14</b>	<b>S13</b>	<b>S12</b>	<b>S11</b>	<b>S10</b>	<b>S9</b>	<b>S8</b>
<b>SUS1</b>	<b>CMP</b>	<b>LB3</b>	<b>LB2</b>	<b>EN4B</b>	<b>SUS2</b>	<b>QE</b>	<b>SRP1</b>

<b>S7</b>	<b>S6</b>	<b>S5</b>	<b>S4</b>	<b>S3</b>	<b>S2</b>	<b>S1</b>	<b>S0</b>
<b>SRP0</b>	<b>BP4</b>	<b>BP3</b>	<b>BP2</b>	<b>BP1</b>	<b>BP0</b>	<b>WEL</b>	<b>WIP</b>

The status and control bits of the Status Register are as follows:

### WIP bit

The Write in Progress (WIP) bit indicates whether the memory is busy in program/erase/write status register progress. When WIP bit sets to 1, means the device is busy in program/erase/write status register progress, when WIP bit sets 0, means the device is not in program/erase/write status register progress.

### WEL bit

The Write Enable Latch (WEL) bit indicates the status of the internal Write Enable Latch. When set to 1 the internal Write Enable Latch is set, when set to 0 the internal Write Enable Latch is reset and no Write Status Register, Program or Erase command is accepted.

### BP4, BP3, BP2, BP1, BP0 bits

The Block Protect (BP4, BP3, BP2, BP1, and BP0) bits are non-volatile. They define the size of the area to be software protected against Program and Erase commands. These bits are written with the Write Status Register (WRSR) command. When the Block Protect (BP4, BP3, BP2, BP1, BP0) bits are set to 1, the relevant memory area (as defined in Table1).becomes protected against Page Program (PP), Sector Erase (SE) and Block Erase (BE) commands. The Block Protect (BP4, BP3, BP2, BP1, and BP0) bits can be written provided that the Hardware Protected mode has not been set. The Chip Erase (CE) command is executed, if the Block Protect (BP2, BP1, and BP0) bits are 0 and CMP=0 or the Block Protect (BP2, BP1, and BP0) bits are 1 and CMP=1

### SRP1, SRP0 bits

The Status Register Protect (SRP1 and SRP0) bits are non-volatile Read/Write bits in the status register. The SRP bits control the method of write protection: software protection, hardware protection, power supply lock-down or one time programmable protection.

<b>SRP1</b>	<b>SRP0</b>	<b>#WP</b>	<b>Status Register</b>	<b>Description</b>
0	0	X	Software Protected	The Status Register can be written to after a Write Enable command, WEL=1.(Default)
0	1	0	Hardware Protected	WP#=0, the Status Register locked and cannot be written to.
0	1	1	Hardware Unprotected	WP#=1, the Status Register is unlocked and can be written to after a Write Enable command, WEL=1.
1	0	X	Power Supply Lock-Down <sup>(1)(2)</sup>	Status Register is protected and cannot be written to again until the next Power-Down, Power-Up cycle.
1	1	X	One Time Program <sup>(2)</sup>	Status Register is permanently protected and cannot be written to.

**NOTE:**

1. When SRP1, SRP0= (1, 0), a Power-Down, Power-Up cycle will change SRP1, SRP0 to (0, 0) state.
2. This feature is available on special order. Please contact GigaDevice for details.

**QE bit.**

The Quad Enable (QE) bit is a non-volatile Read/Write bit in the Status Register that allows Quad operation. When the QE bit is set to 0 (Default) the WP# pin and HOLD# pin are enable. When the QE pin is set to 1, the Quad IO2 and IO3 pins are enabled. (It is best to set the QE bit to 0 to avoid short issue if the WP# or HOLD# pin is tied directly to the power supply or ground)

**LB2, LB3 bits**

The LB2, LB3 bits are non-volatile One Time Program (OTP) bits in Status Register (S12-S13) that provide the write protect control and status to the Security Registers. The default state of LB2-LB3 are 0, the security registers are unlocked. The LB2-LB3 bits can be set to 1 individually using the Write Register instruction. The LB2-LB3 bits are One Time Programmable, once they are set to 1, the Security Registers will become read-only permanently.

**CMP bit**

The CMP bit is a non-volatile Read/Write bit in the Status Register (S14). It is used in conjunction with the BP4-BP0 bits to provide more flexibility for the array protection. Please see the Status registers Memory Protection table for details. The default setting is CMP=0.

**SUS1, SUS2 bit**

The SUS1 and SUS2 bits are read only bit in the status register (S15 and S10) that are set to 1 after executing an Erase/Program Suspend (75H) command (The Erase Suspend will set the SUS1 to 1, and the Program Suspend will set the SUS2 to 1). The SUS1 and SUS2 bit are cleared to 0 by Erase/Program Resume (7AH) command, software reset (66H+99H) command as well as a power-down, power-up cycle.

**EN4B bit**

The EN4B bit is a volatile Read/Write bit in the status register (S11) that is set to 1 after executing the Enable 4-byte Mode command, and cleared to 0 (default ) by the Disable 4-byte Mode command as well as a power-down, power-up cycle.

## 7. COMMANDS DESCRIPTION

All commands, addresses and data are shifted in and out of the device, beginning with the most significant bit on the first rising edge of SCLK after CS# is driven low. Then, the one-byte command code must be shifted in to the device, with most significant bit first on SI, and each bit is latched on the rising edges of SCLK.

See Table2, every command sequence starts with a one-byte command code. Depending on the command, this might be followed by address bytes, or by data bytes, or by both or none. CS# must be driven high after the last bit of the command sequence has been completed. For the command of Read, Fast Read, Read Status Register or Release from Deep Power-Down, and Read Device ID, the shifted-in command sequence is followed by a data-out sequence. All read instruction can be completed after any bit of the data-out sequence is being shifted out, and then CS# must be driven high to return to deselected status.

For the command of Page Program, Sector Erase, Block Erase, Chip Erase, Write Status Register, Write Enable, Write Disable or Deep Power-Down command, CS# must be driven high exactly at a byte boundary, otherwise the command is rejected, and is not executed. That is CS# must be driven high when the number of clock pulses after CS# being driven low is an exact multiple of eight. For Page Program, if at any time the input byte is not a full byte, nothing will happen and WEL will not be reset.

**Table2. Commands (Standard/Dual/Quad SPI) (3-byte mode)**

Command Name	Byte 1	Byte 2	Byte 3	Byte 4	Byte 5	Byte 6	n-Bytes
Write Enable	06H						
Write Disable	04H						
Volatile SR Write Enable	50H						
Read Status Register	05H	(S7-S0)					(continuous)
Read Status Register-1	35H	(S15-S8)					(continuous)
Write Status Register	01H	S7-S0	S15-S8				
Read Data	03H	A23-A16	A15-A8	A7-A0	(D7-D0)	(Next byte)	(continuous)
Fast Read	0BH	A23-A16	A15-A8	A7-A0	dummy	(D7-D0)	(continuous)
Dual Output Fast Read	3BH	A23-A16	A15-A8	A7-A0	dummy	(D7-D0) <sup>(1)</sup>	(continuous)
Dual I/O Fast Read	BBH	A23-A8 <sup>(2)</sup>	A7-A0 M7-M0 <sup>(2)</sup>	(D7-D0) <sup>(1)</sup>			(continuous)
Quad Output Fast Read	6BH	A23-A16	A15-A8	A7-A0	dummy	(D7-D0) <sup>(3)</sup>	(continuous)
Quad I/O Fast Read	EBH	A23-A0 M7-M0 <sup>(4)</sup>	dummy <sup>(5)</sup>	(D7-D0) <sup>(3)</sup>			(continuous)
Quad I/O Word Fast Read <sup>(7)</sup>	E7H	A23-A0 M7-M0 <sup>(4)</sup>	dummy <sup>(6)</sup>	(D7-D0) <sup>(3)</sup>			(continuous)
Page Program	02H	A23-A16	A15-A8	A7-A0	D7-D0	Next byte	
Quad Page Program	32H	A23-A16	A15-A8	A7-A0	D7-D0		
Sector Erase	20H	A23-A16	A15-A8	A7-A0			
Block Erase(32K)	52H	A23-A16	A15-A8	A7-A0			
Block Erase(64K)	D8H	A23-A16	A15-A8	A7-A0			
Chip Erase	C7/60H						
Enable QPI	38H						
Enable Reset	66H						
Reset	99H						
Set Burst with Wrap	77H	W6-W4					
Program/Erase Suspend	75H						
Program/Erase Resume	7AH						

Release From Deep Power-Down, And Read Device ID	ABH	dummy	dummy	dummy	(ID7-ID0)		(continuous)
Release From Deep Power-Down	ABH						
Deep Power-Down	B9H						
Manufacturer/ Device ID	90H	dummy	dummy	00H	(M7-M0)	(ID7-ID0)	(continuous)
Manufacturer/ Device ID by Dual I/O	92H	A23-A8	A7-A0, M[7:0]	(M7-M0) (ID7-ID0)			(continuous)
Manufacturer/ Device ID by Quad I/O	94H	A23-A0, M[7:0]	dummy	(M7-M0) (ID7-ID0)			(continuous)
Read Identification	9FH	(M7-M0)	(ID15-ID8)	(ID7-ID0)			(continuous)
Read Unique ID	4BH	00H	00H	00H	dummy	(UID7-UID0)	(continuous)
Read Serial Flash Discoverable Parameter <sup>(10)</sup>	5AH	A23-A16	A15-A8	A7-A0	dummy	(D7-D0)	(continuous)
Erase Security Registers <sup>(8)</sup>	44H	A23-A16	A15-A8	A7-A0			
Program Security Registers <sup>(8)</sup>	42H	A23-A16	A15-A8	A7-A0	D7-D0	D7-D0	
Read Security Registers <sup>(8)</sup>	48H	A23-A16	A15-A8	A7-A0	dummy	(D7-D0)	
Enable 4-byte Mode	B7H						
Disable 4-byte Mode	E9H						

**Table2.1. Commands (Standard/Dual/Quad SPI) (4-byte mode)**

Command Name	Byte 1	Byte 2	Byte 3	Byte 4	Byte 5	Byte 6	Byte 7
Read Data	03H	A31-A24	A23-A16	A15-A8	A7-A0	(D7-D0)	(Next byte)
Fast Read	0BH	A31-A24	A23-A16	A15-A8	A7-A0	dummy	(D7-D0)
Dual Output Fast Read	3BH	A31-A24	A23-A16	A15-A8	A7-A0	dummy	(D7-D0) <sup>(1)</sup>
Dual I/O Fast Read	BBH	A31-A24	A23-A8 <sup>(2)</sup>	A7-A0 M7-M0 <sup>(2)</sup>	(D7-D0) <sup>(1)</sup>		
Quad Output Fast Read	6BH	A31-A24	A23-A16	A15-A8	A7-A0	dummy	(D7-D0) <sup>(3)</sup>
Quad I/O Fast Read	EBH	A31-A0	M7-M0 <sup>(4)</sup>	dummy <sup>(5)</sup>	(D7-D0) <sup>(3)</sup>		
Quad I/O Word Fast Read <sup>(7)</sup>	E7H	A31-A0	M7-M0 <sup>(4)</sup>	dummy <sup>(6)</sup>	(D7-D0) <sup>(3)</sup>		
Page Program	02H	A31-A24	A23-A16	A15-A8	A7-A0	D7-D0	Next byte
Quad Page Program	32H	A31-A24	A23-A16	A15-A8	A7-A0	D7-D0	
Sector Erase	20H	A31-A24	A23-A16	A15-A8	A7-A0		
Block Erase(32K)	52H	A31-A24	A23-A16	A15-A8	A7-A0		
Block Erase(64K)	D8H	A31-A24	A23-A16	A15-A8	A7-A0		

Table2a. Commands (QPI) (3-byte mode)

Command Name	Byte 1	Byte 2	Byte 3	Byte 4	Byte 5	Byte 6
Clock Number	(0,1)	(2,3)	(4,5)	(6,7)	(8,9)	(10,11)
Write Enable	06H					
Volatile SR Write Enable	50H					
Write Disable	04H					
Read Status Register	05H	(S7-S0)				
Read Status Register-1	35H	(S15-S8)				
Read Status Register-2	15H	(S1-S0)				
Write Status Register	01H	S7-S0	S15-S8			
Page Program	02H	A23-A16	A15-A8	A7-A0	D7-D0	Next byte
Sector Erase	20H	A23-A16	A15-A8	A7-A0		
Block Erase(32K)	52H	A23-A16	A15-A8	A7-A0		
Block Erase(64K)	D8H	A23-A16	A15-A8	A7-A0		
Chip Erase	C7/60H					
Program/Erase Suspend	75H					
Program/Erase Resume	7AH					
Deep Power-Down	B9H					
Set Read Parameters	C0H	P7-P0				
Fast Read	0BH	A23-A16	A15-A8	A7-A0	dummy	(D7-D0)
Burst Read with Wrap	0CH	A23-A16	A15-A8	A7-A0	dummy	(D7-D0)
Burst Read with Wrap for Lower 128Mb (A24=0)	8CH	A23-A16	A15-A8	A7-A0	dummy	(D7-D0)
Burst Read with Wrap for Higher 128Mb (A24=1)	8DH	A23-A16	A15-A8	A7-A0	dummy	(D7-D0)
Quad I/O Fast Read	EBH	A23-A16	A15-A8	A7-A0	M7-M0	(D7-D0)
Release From Deep Power-Down, And Read Device ID	ABH	dummy	dummy	dummy	(ID7-ID0)	
Manufacturer/ Device ID	90H	dummy	dummy	00H	(M7-M0)	(ID7-ID0)
Read Identification	9FH	(M7-M0)	(ID15-ID8)	(ID7-ID0)		
Read Serial Flash Discoverable Parameter <sup>(10)</sup>	5AH	A23-A16	A15-A8	A7-A0	dummy	(D7-D0)
Disable QPI	FFH					
Enable Reset	66H					
Reset	99H					
Enable 4-byte Mode	B7H					
Disable 4-byte Mode	E9H					

Table2a.1. Commands (QPI) (4-byte mode)

Command Name	Byte 1	Byte 2	Byte 3	Byte 4	Byte 5	Byte 6	Byte7
Clock Number	(0,1)	(2,3)	(4,5)	(6,7)	(8,9)	(10,11)	(12,13)
Page Program	02H	A31-A24	A23-A16	A15-A8	A7-A0	D7-D0	Next byte
Sector Erase	20H	A31-A24	A23-A16	A15-A8	A7-A0		
Block Erase(32K)	52H	A31-A24	A23-A16	A15-A8	A7-A0		
Block Erase(64K)	D8H	A31-A24	A23-A16	A15-A8	A7-A0		
Fast Read	0BH	A31-A24	A23-A16	A15-A8	A7-A0	dummy	(D7-D0)
Burst Read with Wrap	0CH	A31-A24	A23-A16	A15-A8	A7-A0	dummy	(D7-D0)
Quad I/O Fast Read	EBH	A31-A24	A23-A16	A15-A8	A7-A0	M7-M0	(D7-D0)

NOTE:

1. Dual Output data

IO0 = (D6, D4, D2, D0)

IO1 = (D7, D5, D3, D1)

2. Dual Input Address

IO0 = A22, A20, A18, A16, A14, A12, A10, A8      A6, A4, A2, A0, M6, M4, M2, M0

IO1 = A23, A21, A19, A17, A15, A13, A11, A9      A7, A5, A3, A1, M7, M5, M3, M1

3. Quad Output Data

IO0 = (D4, D0, .....)

IO1 = (D5, D1, .....)

IO2 = (D6, D2, .....)

IO3 = (D7, D3,.....)

4. Quad Input Address

IO0 = A20, A16, A12, A8,    A4, A0, M4, M0

IO1 = A21, A17, A13, A9,    A5, A1, M5, M1

IO2 = A22, A18, A14, A10, A6, A2, M6, M2

IO3 = A23, A19, A15, A11, A7, A3, M7, M3

5. Fast Read Quad I/O Data

IO0 = (x, x, x, x, D4, D0,...)

IO1 = (x, x, x, x, D5, D1,...)

IO2 = (x, x, x, x, D6, D2,...)

IO3 = (x, x, x, x, D7, D3,...)

6. Fast Word Read Quad I/O Data

IO0 = (x, x, D4, D0,...)

IO1 = (x, x, D5, D1,...)

IO2 = (x, x, D6, D2,...)

IO3 = (x, x, D7, D3,...)

7. Fast Word Read Quad I/O Data: the lowest address bit must be 0.

8. Security Registers Address:

Security Register2: A23-A16=00H, A15-A10=001000b, A9-A0=Byte Address;

Security Register3: A23-A16=00H, A15-A10=001100b, A9-A0=Byte Address.

9. QPI Command, Address, Data input/output format:

CLK #0	1	2	3	4	5	6	7	8	9	10	11
IO0=	C4, C0,	A20, A16,	A12, A8,	A4, A0,	D4, D0,	D4, D0,					
IO1=	C5, C1,	A21, A17,	A13, A9,	A5, A1,	D5, D1,	D5, D1,					
IO2=	C6, C2,	A22, A18,	A14, A10,	A6, A2,	D6, D2,	D6, D2,					
IO3=	C7, C3,	A23, A19,	A15, A11,	A7, A3,	D7, D3,	D7, D3,					





**Table of ID Definitions:**

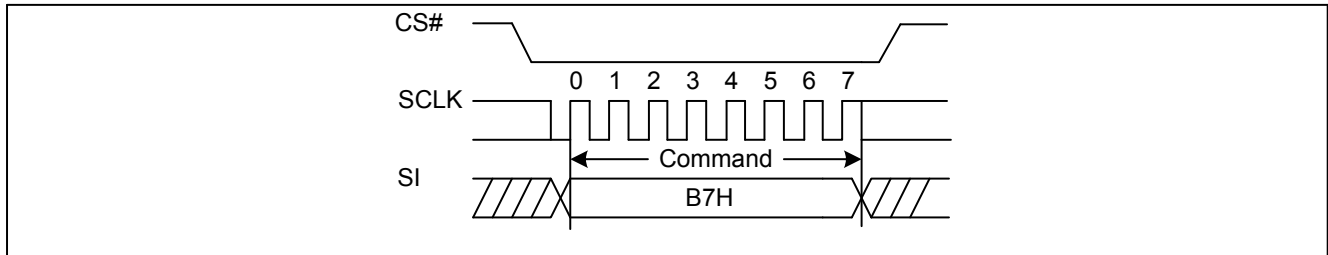
**GD25LE256D**

<b>Operation Code</b>	<b>M7-M0</b>	<b>ID15-ID8</b>	<b>ID7-ID0</b>
9FH	C8	60	19
90H	C8		18
ABH			18

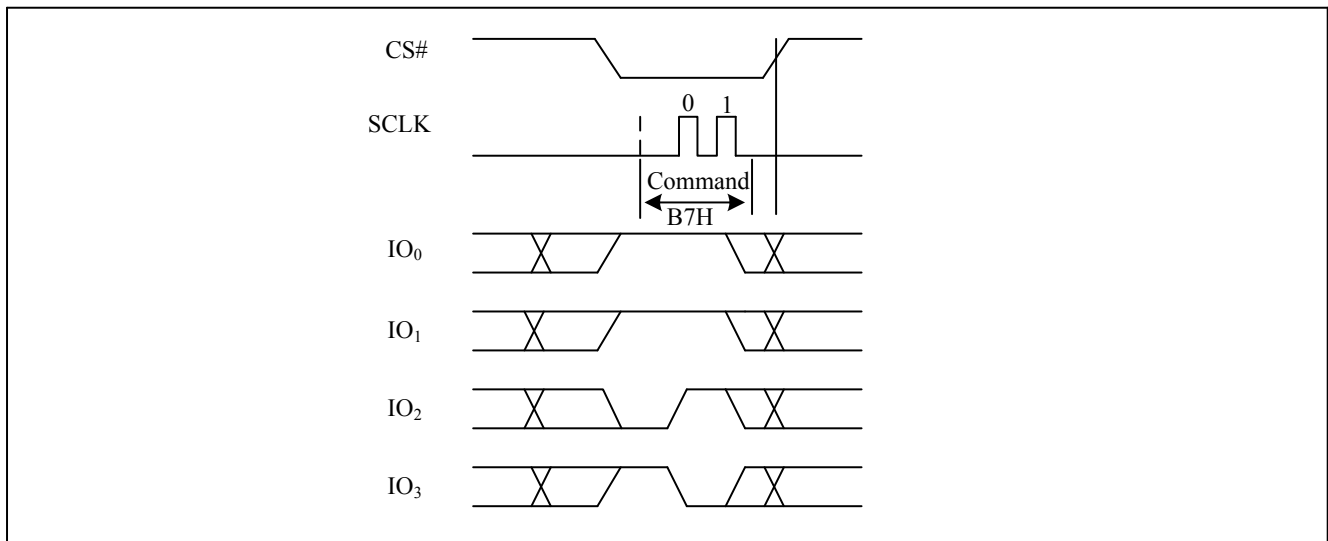
**7.1. Enable 4-byte Mode (B7H)**

The Enable 4-byte Mode command enables accessing the address length of 32-bit for the memory area of the higher density (larger than 128Mb). The GD25LE256D default is in 24-bit address mode. After sending the Enable 4-byte Mode command, the EN4B bit (S11) will be set to 1 to indicate the 4-byte address mode has been enabled. Once the 4-byte address mode is enabled, the address length becomes 32-bit instead of the default 24 bit. The Disable 4-byte mode or Reset or Power-off will disable 4-byte mode. In the 4-byte mode, A31-A25 are don't care.

**Figure2. Enable 4-byte Mode Sequence Diagram**



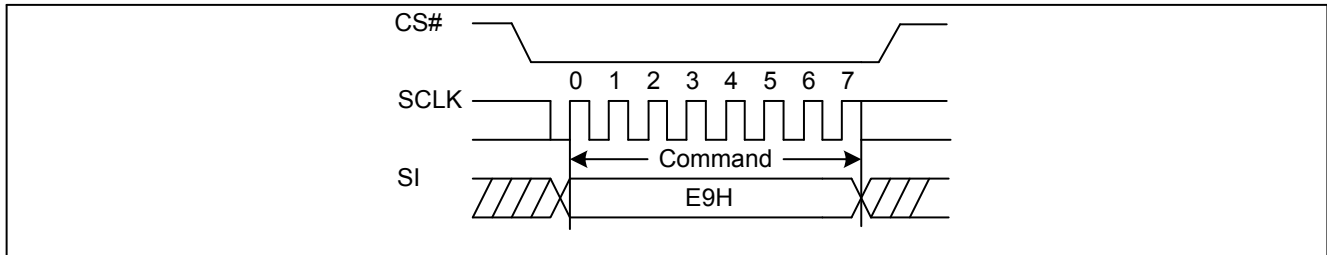
**Figure2a. Enable 4-byte Mode Sequence Diagram (QPI)**



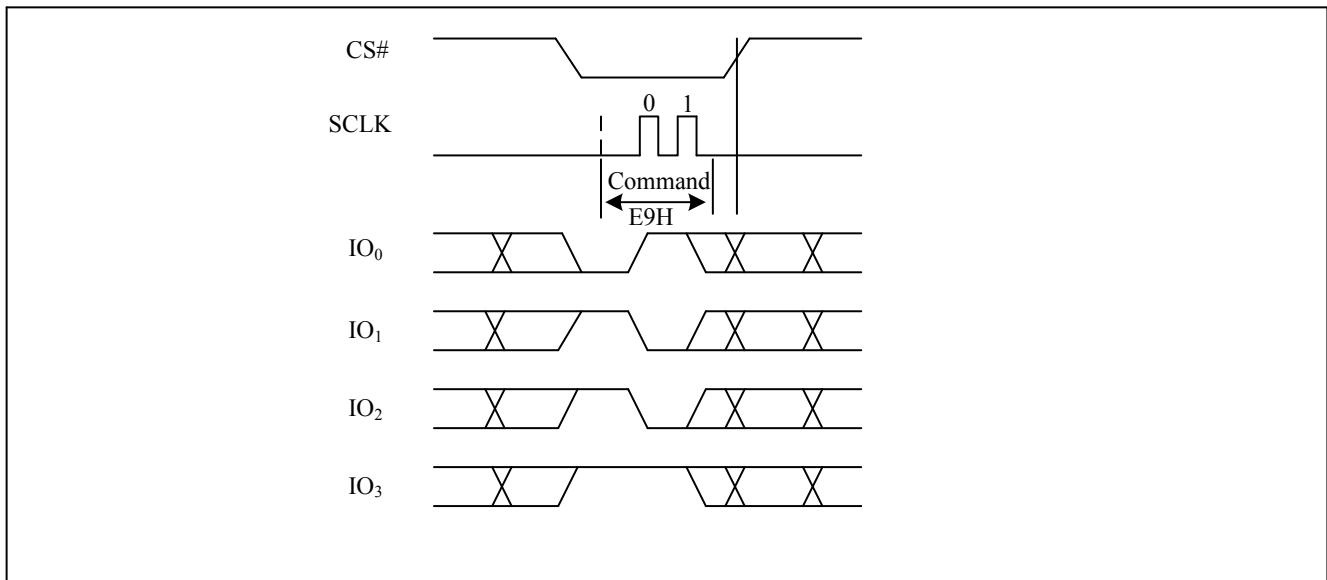
**7.2. Disable 4-byte Mode (E9H)**

The Disable 4-byte Mode command is executed to exit the 4-byte address mode and return to the default 3-byte address mode. After sending the Disable 4-byte Mode command, the EN4B bit (S11) will be clear to be 0 to indicate the 4-byte address mode has been disabled, and then the address length will return to 24-bit.

**Figure3. Disable 4-byte Mode Sequence Diagram**



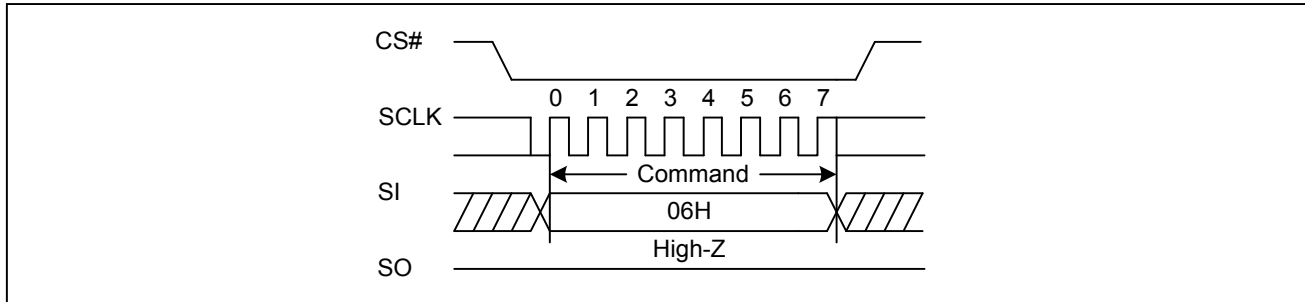
**Figure3a. Disable 4-byte Mode Sequence Diagram (QPI)**



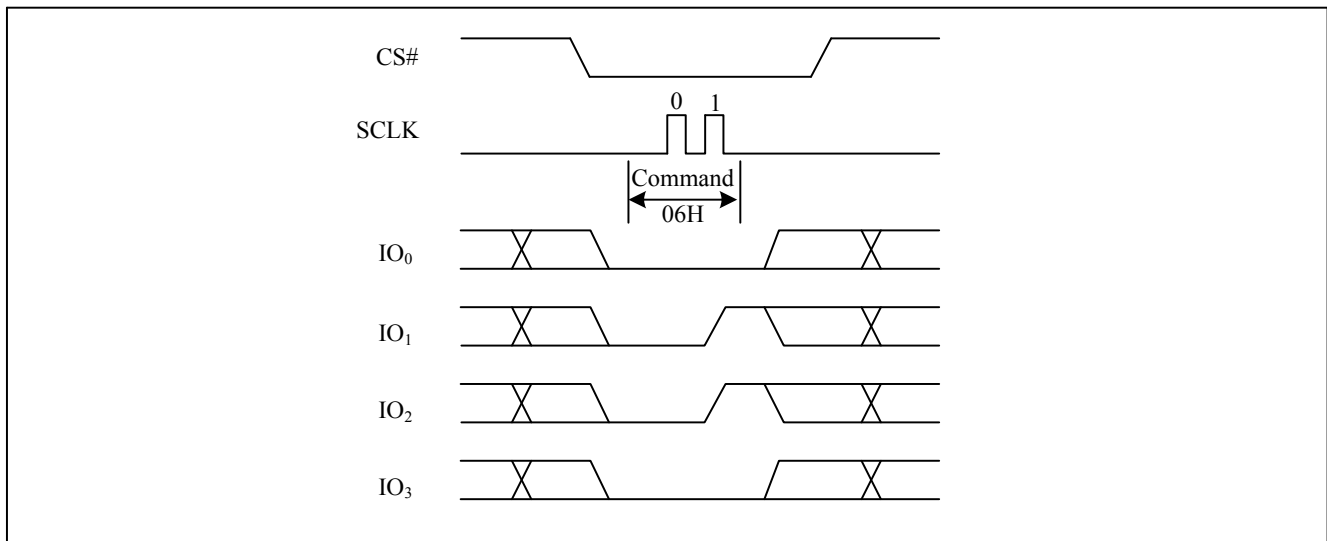
### 7.3. Write Enable (WREN) (06H)

The Write Enable (WREN) command is for setting the Write Enable Latch (WEL) bit. The Write Enable Latch (WEL) bit must be set prior to every Page Program (PP), Sector Erase (SE), Block Erase (BE), Chip Erase (CE), Write Status Register (WRSR) and Erase/Program Security Registers command. The Write Enable (WREN) command sequence: CS# goes low → sending the Write Enable command → CS# goes high.

**Figure4. Write Enable Sequence Diagram**



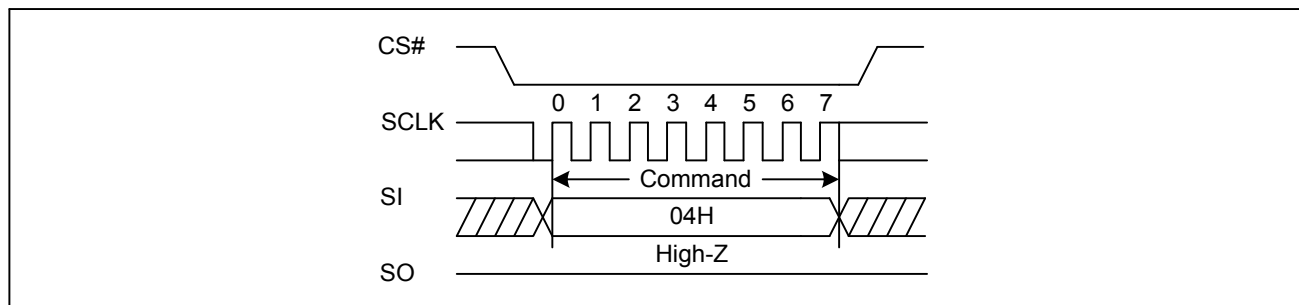
**Figure4a. Write Enable Sequence Diagram (QPI)**



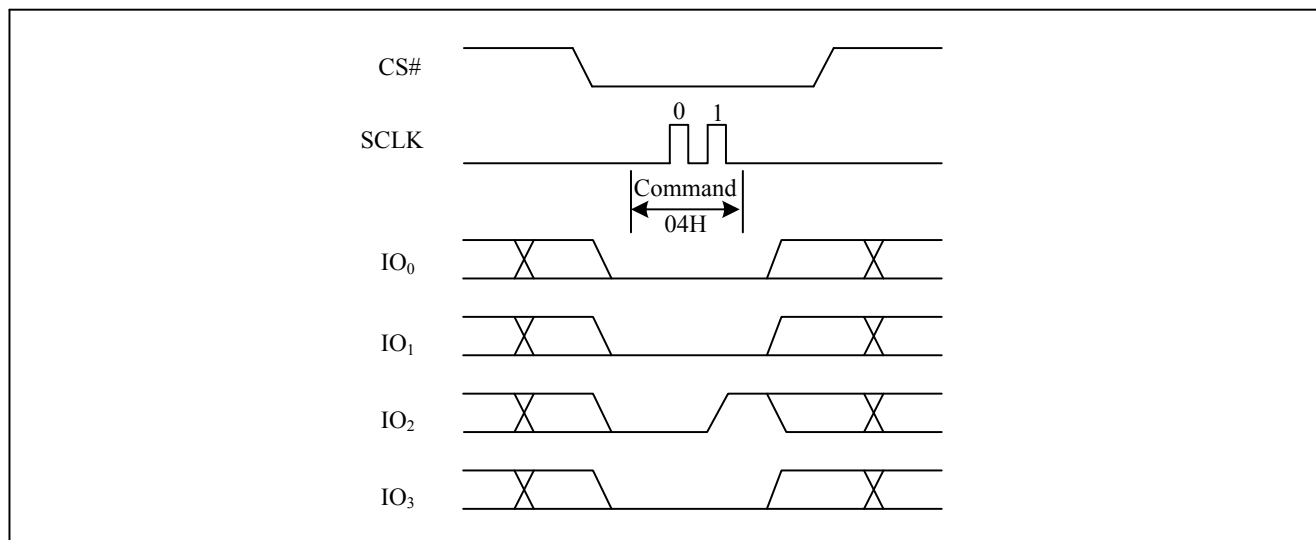
### 7.4. Write Disable (WRDI) (04H)

The Write Disable command is for resetting the Write Enable Latch (WEL) bit. The Write Disable command sequence: CS# goes low → Sending the Write Disable command → CS# goes high. The WEL bit is reset by following condition: Power-up and upon completion of the Write Status Register, Page Program, Sector Erase, Block Erase, Chip Erase, Erase/Program Security Registers and Reset commands.

**Figure5. Write Disable Sequence Diagram**



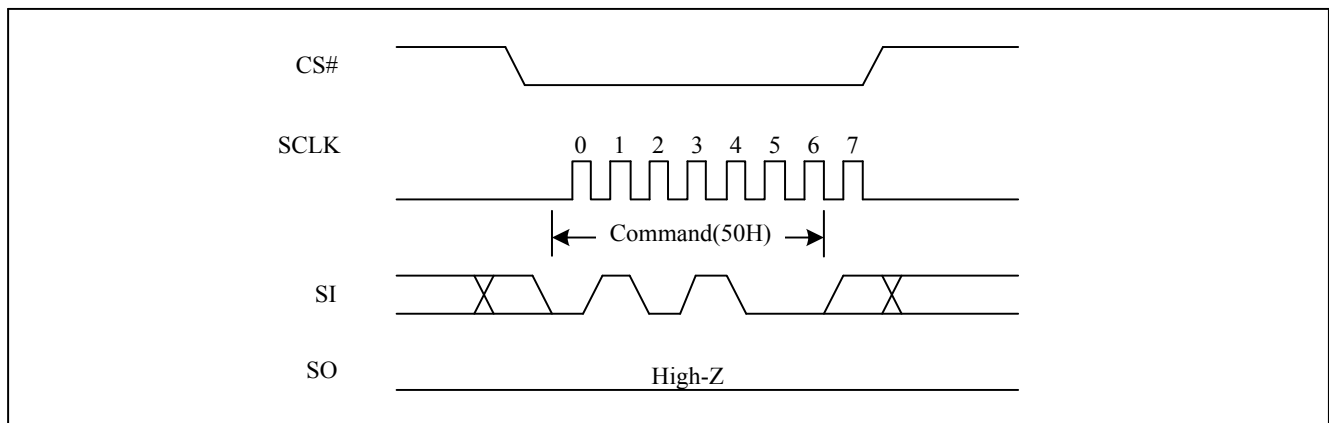
**Figure5a. Write Disable Sequence Diagram (QPI)**



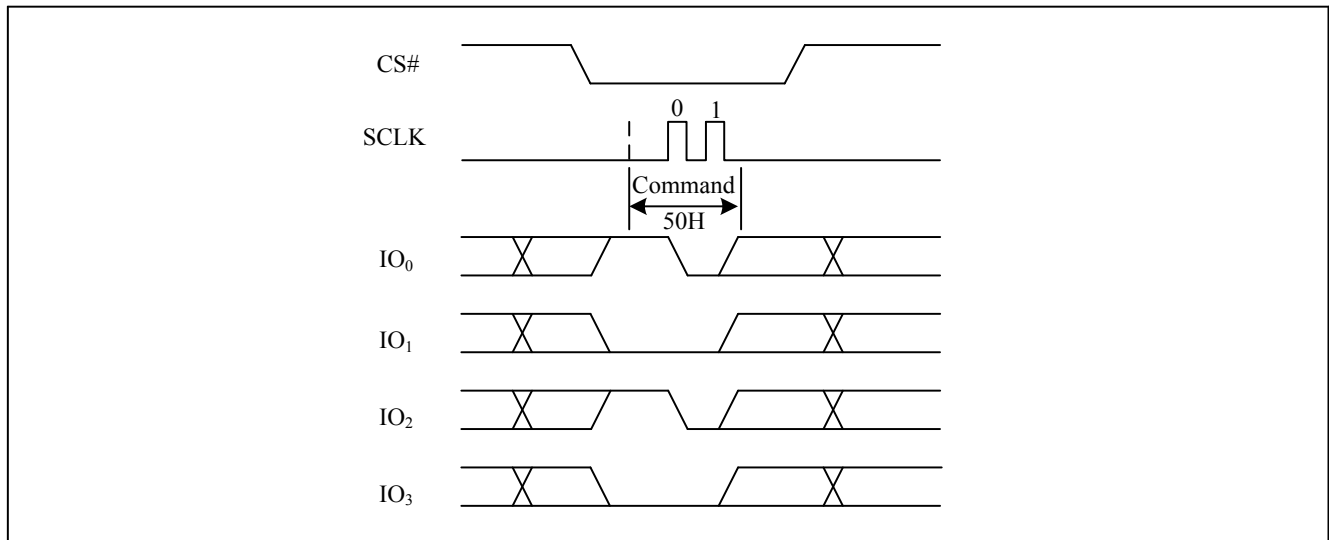
**7.5. Write Enable for Volatile Status Register (50H)**

The non-volatile Status Register bits can also be written to as volatile bits. This gives more flexibility to change the system configuration and memory protection schemes quickly without waiting for the typical non-volatile bit write cycles or affecting the endurance of the Status Register non-volatile bits. The Write Enable for Volatile Status Register command must be issued prior to a Write Status Register command, and any other commands can't be inserted between them. Otherwise, Write Enable for Volatile Status Register will be cleared. The Write Enable for Volatile Status Register command will not set the Write Enable Latch bit, it is only valid for the Write Status Register command to change the volatile Status Register bit values.

**Figure6. Write Enable for Volatile Status Register Sequence Diagram**



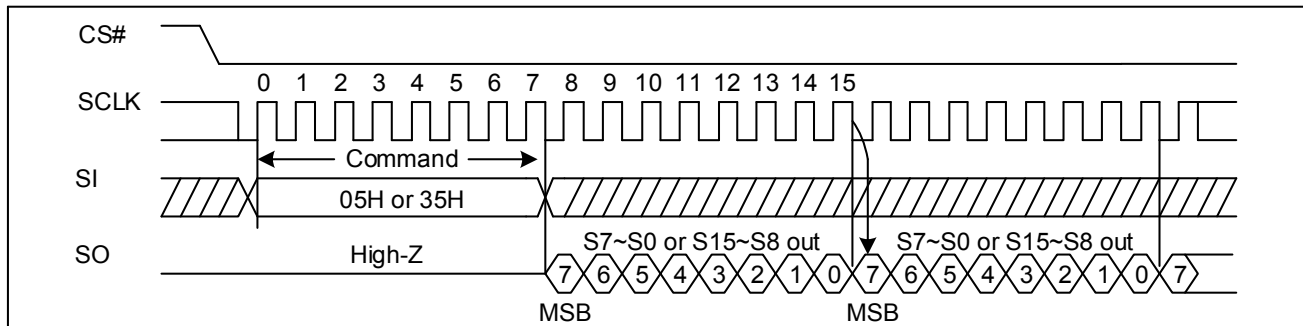
**Figure6a. Write Enable for Volatile Status Register Sequence Diagram (QPI)**



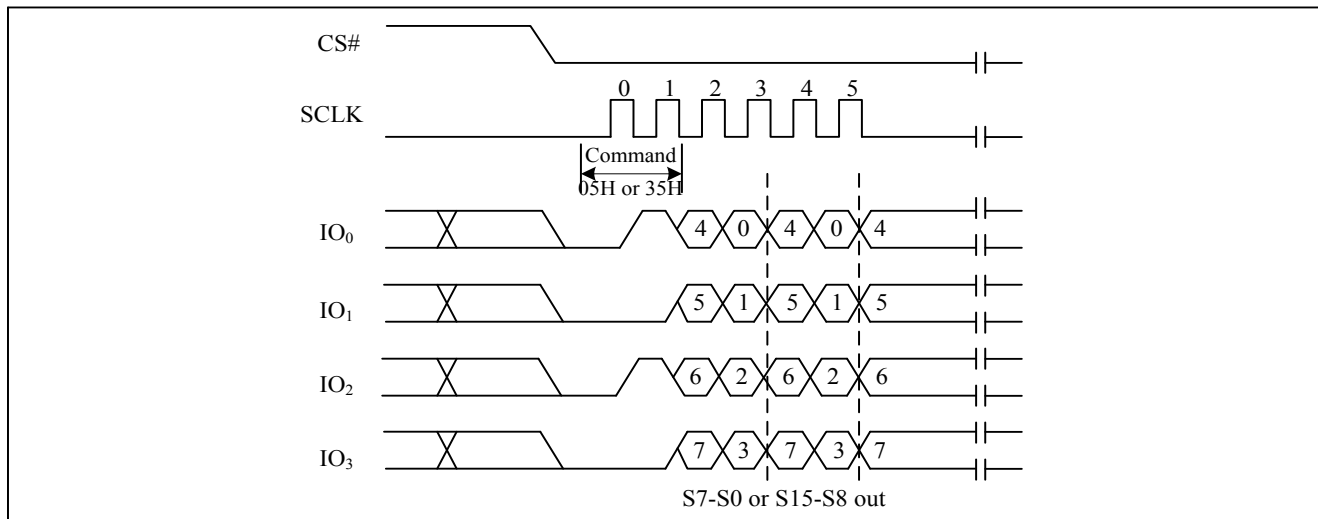
**7.6. Read Status Register (RDSR) (05H or 35H or 15H)**

The Read Status Register (RDSR) command is for reading the Status Register. The Status Register may be read at any time, even while a Program, Erase or Write Status Register cycle is in progress. When one of these cycles is in progress, it is recommended to check the Write in Progress (WIP) bit before sending a new command to the device. It is also possible to read the Status Register continuously. For command code "05H" / "35H", the SO will output Status Register bits S7~S0 / S15-S8. The command code "15H" only supports the QPI mode, the I/O0 will output Status Register S1-S0. (For 120MHz Frequency, the 15H will better than 05H to check the WIP bit)

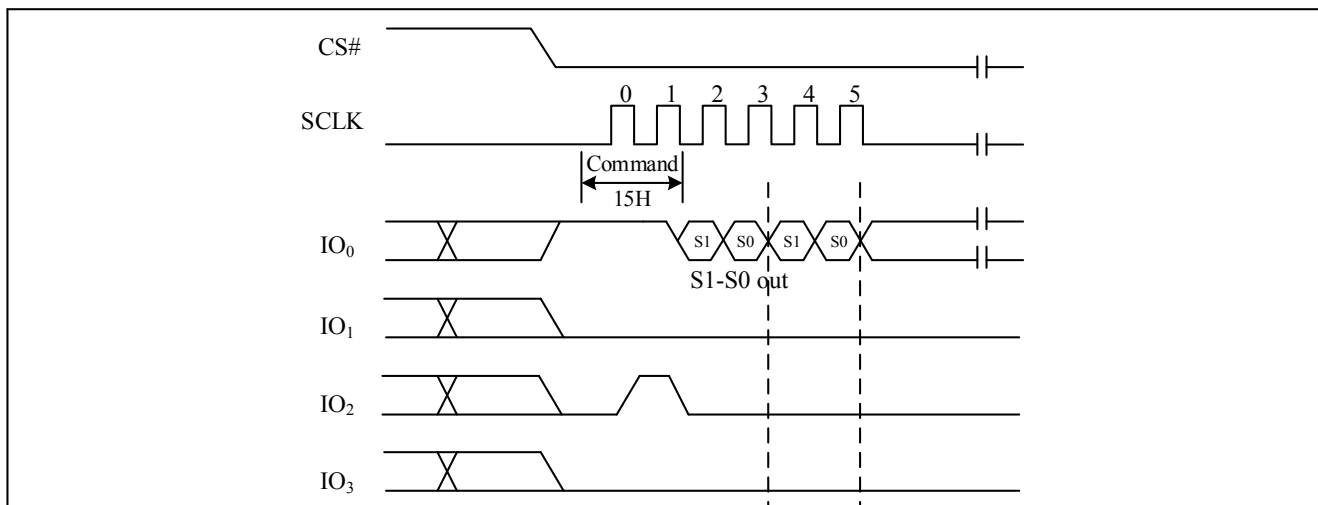
**Figure7. Read Status Register Sequence Diagram**



**Figure7a. Read Status Register Sequence Diagram (QPI)**



**Figure7b. Read Status Register Sequence Diagram (QPI) (15H)**



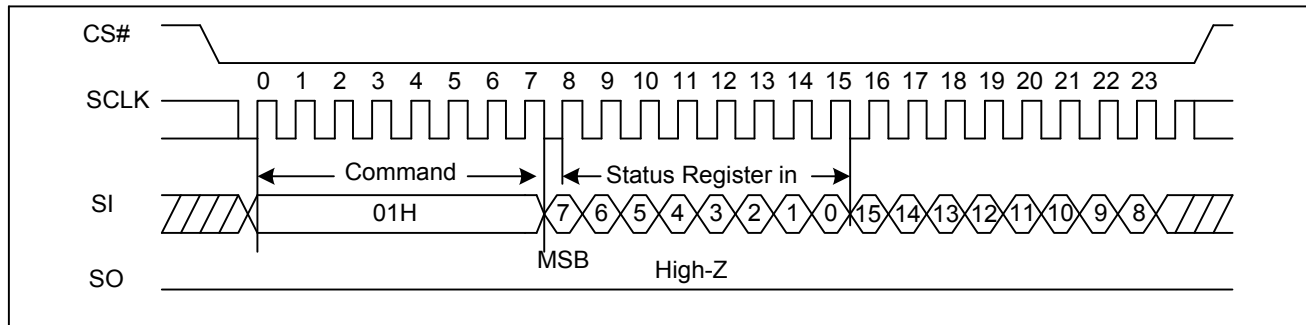
**7.7. Write Status Register (WRSR) (01H)**

The Write Status Register (WRSR) command allows new values to be written to the Status Register. Before it can be accepted, a Write Enable (WREN) command must previously have been executed. After the Write Enable (WREN) command has been decoded and executed, the device sets the Write Enable Latch (WEL).

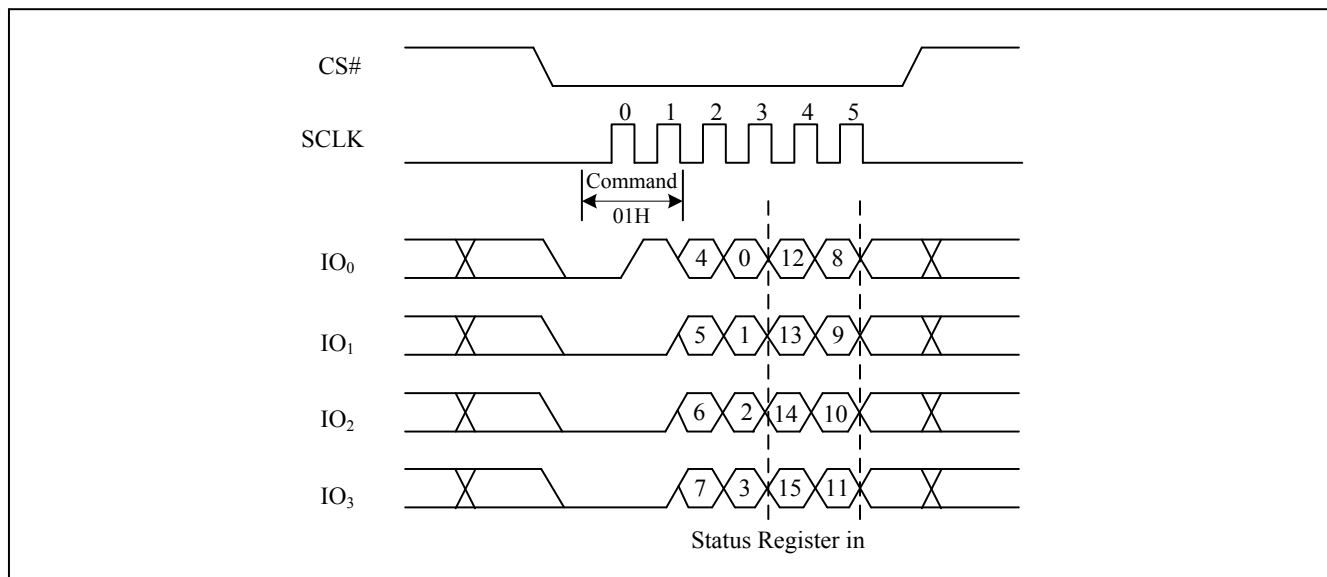
The Write Status Register (WRSR) command has no effect on S15, S11, S10, S1 and S0 of the Status Register. CS# must be driven high after the eighth or sixteen bit of the data byte has been latched in. If not, the Write Status Register (WRSR) command is not executed. If CS# is driven high after eighth bit of the data byte, the CMP and QE bits will be cleared to 0 in SPI mode, while only CMP will be cleared to 0 in QPI mode. As soon as CS# is driven high, the self-timed Write Status Register cycle (whose duration is  $t_w$ ) is initiated. While the Write Status Register cycle is in progress, the Status Register may still be read to check the value of the Write In Progress (WIP) bit. The Write In Progress (WIP) bit is 1 during the self-timed Write Status Register cycle, and is 0 when it is completed. When the cycle is completed, the Write Enable Latch (WEL) is reset.

The Write Status Register (WRSR) command allows the user to change the values of the Block Protect (BP4, BP3, BP2, BP1, and BP0) bits, to define the size of the area that is to be treated as read-only, as defined in Table1. The Write Status Register (WRSR) command also allows the user to set or reset the Status Register Protect (SRP1 and SRP0) bits in accordance with the Write Protect (WP#) signal. The Status Register Protect (SRP1 and SRP0) bits and Write Protect (WP#) signal allow the device to be put in the Hardware Protected Mode. The Write Status Register (WRSR) command is not executed once the Hardware Protected Mode is entered.

**Figure8. Write Status Register Sequence Diagram**



**Figure8a. Write Status Register Sequence Diagram (QPI)**

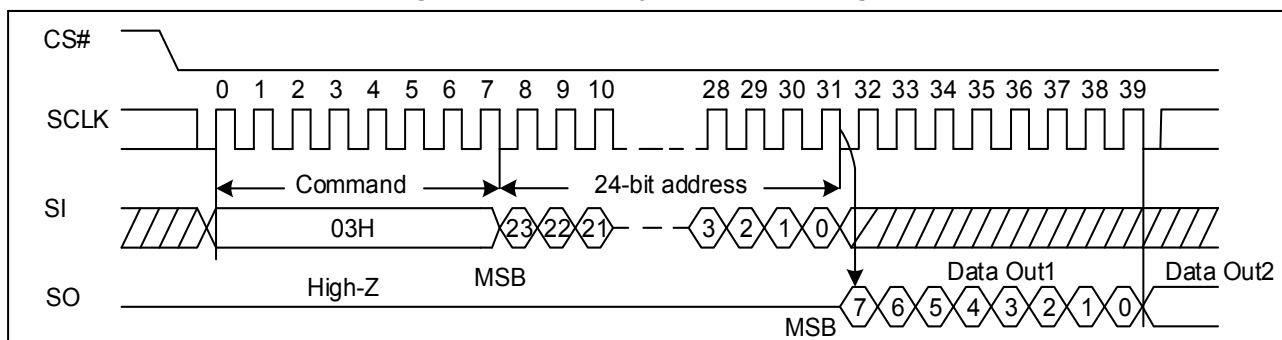




### 7.8. Read Data Bytes (READ) (03H)

The Read Data Bytes (READ) command is followed by a 3-byte address (A23-A0) or a 4-byte address (A31-A0), and each bit is latched-in on the rising edge of SCLK. Then the memory content, at that address, is shifted out on SO, and each bit is shifted out, at a Max frequency  $f_R$ , on the falling edge of SCLK. The first byte addressed can be at any location. The address is automatically incremented to the next higher address after each byte of data is shifted out. The default read mode is 3-byte address mode, and the lower 128Mbit can be read with a single Read Data Byte (03H) command. By entering 4-byte address mode, or to set EN4B (S11) bit to 1, the higher 128Mbit can be read with a single Read Data Byte (03H) command. Any Read Data Bytes (03H) command, while an Erase, Program or Write cycle is in progress, is rejected without having any effects on the cycle that is in progress.

**Figure9. Read Data Bytes Sequence Diagram**

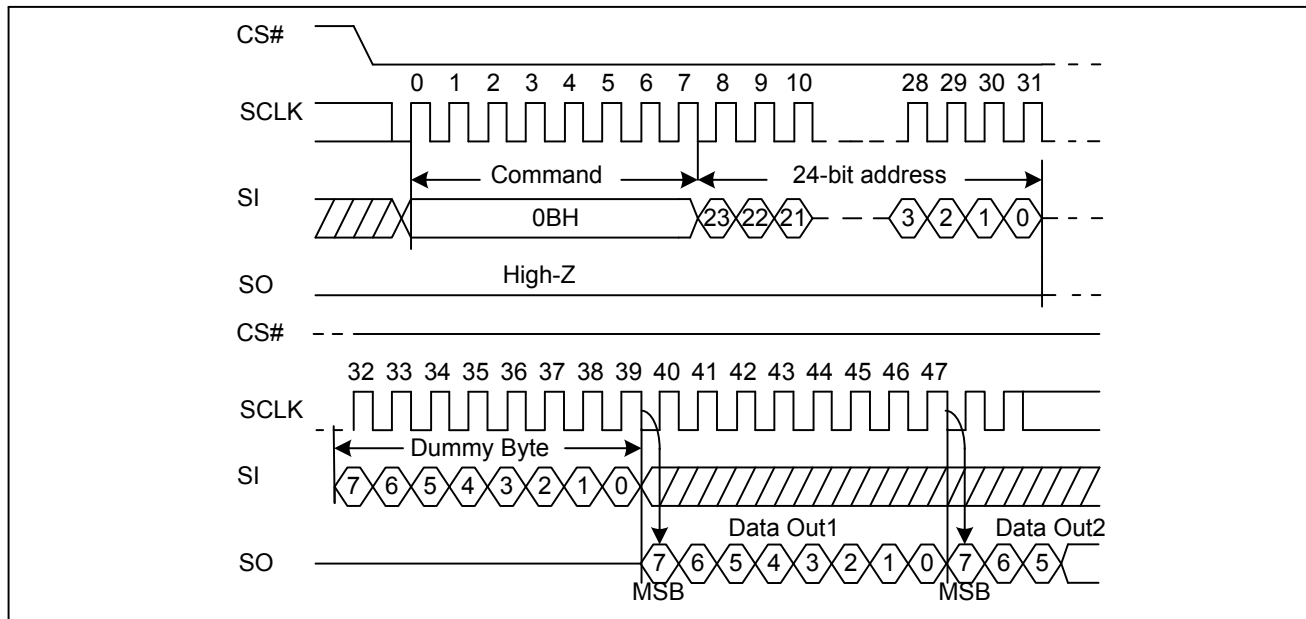


Note: The device default is in 24-bit address mode. For 4-byte mode, the address length becomes 32-bit.

**7.9. Read Data Bytes at Higher Speed (Fast Read) (0BH)**

The Read Data Bytes at Higher Speed (Fast Read) command is for quickly reading data out. It is followed by a 3-byte address (A23-A0) or a 4-byte address (A31-A0) and a dummy byte, and each bit is latched-in on the rising edge of SCLK. Then the memory content, at that address, is shifted out on SO, and each bit is shifted out, at a Max frequency  $f_c$ , on the falling edge of SCLK. The first byte addressed can be at any location. The address is automatically incremented to the next higher address after each byte of data is shifted out. The default read mode is 3-byte address mode, and the lower 128Mbit can be read with a single Read Data Byte at Higher Speed (0BH) command. By entering 4-byte address mode, or to set EN4B (S11) bit to 1, the higher 128Mbit can be read with a single Read Data Byte at Higher Speed (0BH) command.

**Figure10. Read Data Bytes at Higher Speed Sequence Diagram**

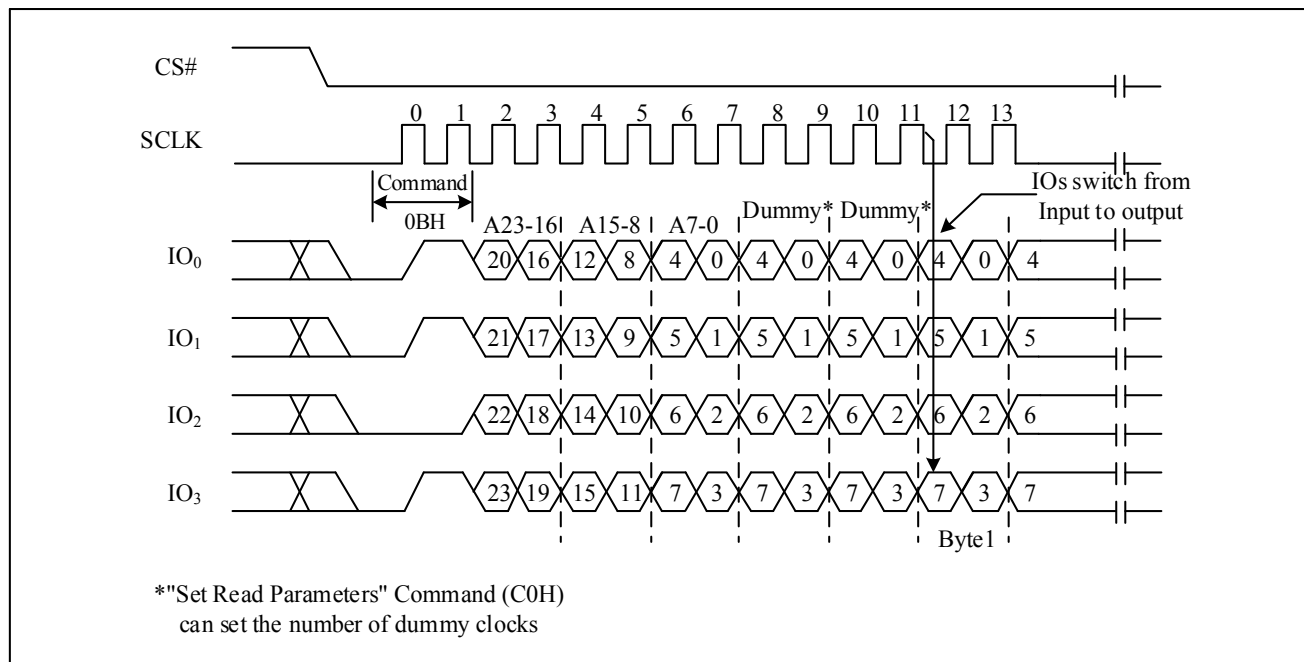


Note: The device default is in 24-bit address mode. For 4-byte mode, the address length becomes 32-bit.

**Fast Read (0BH) in QPI mode**

The Fast Read command is also supported in QPI mode. In QPI mode, the number of dummy clocks is configured by the "Set Read Parameters (C0H)" command to accommodate a wide range application with different needs for either maximum Fast Read frequency or minimum data access latency. Depending on the Read Parameter Bits P[5:4] setting, the number of dummy clocks can be configured as either 4/6/8/8.

**Figure10a. Read Data Bytes at Higher Speed Sequence Diagram (QPI)**

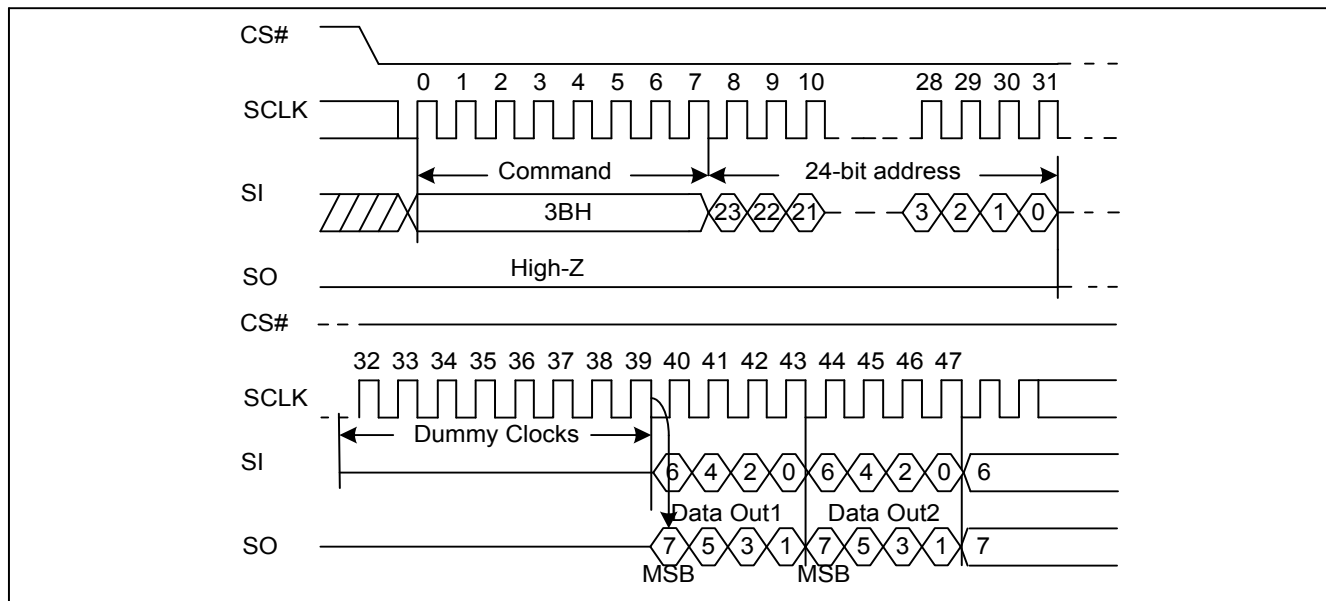


Note: The device default is in 24-bit address mode. For 4-byte mode, the address length becomes 32-bit.

**7.10. Dual Output Fast Read (3BH)**

The Dual Output Fast Read command is followed by 3-byte address (A23-A0) or a 4-byte address (A31-A0) and a dummy byte, and each bit is latched in on the rising edge of SCLK, then the memory contents are shifted out 2-bit per clock cycle from SI and SO. The command sequence is shown in followed Figure11. The first byte addressed can be at any location. The address is automatically incremented to the next higher address after each byte of data is shifted out. The default read mode is 3-byte address mode, and the lower 128Mbit can be read with a single Dual Output Fast Read (3BH) command. By entering 4-byte address mode, or to set EN4B (S11) bit to 1, the higher 128Mbit can be read with a single Dual Output Fast Read (3BH) command.

**Figure11. Dual Output Fast Read Sequence Diagram**

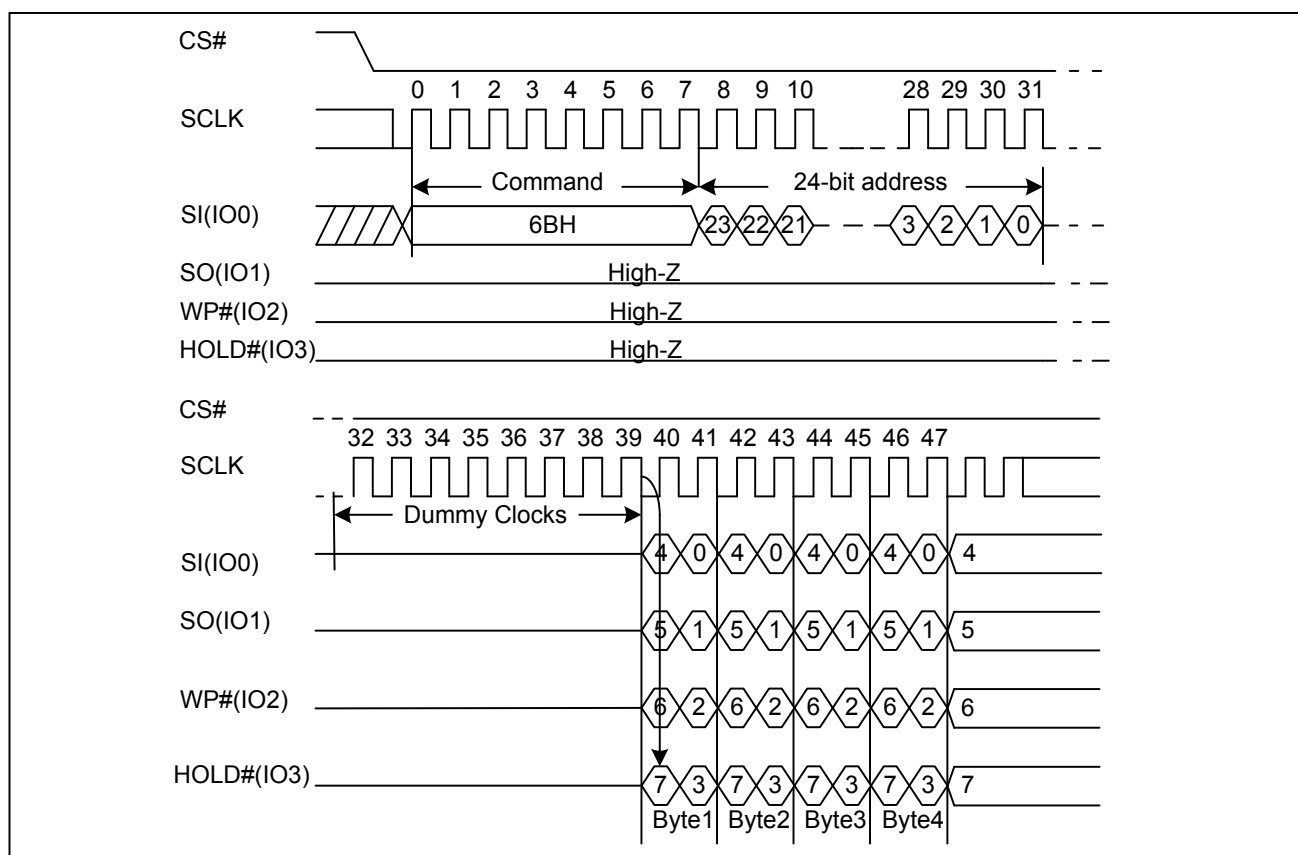


Note: The device default is in 24-bit address mode. For 4-byte mode, the address length becomes 32-bit.

### 7.11. Quad Output Fast Read (6BH)

The Quad Output Fast Read command is followed by 3-byte address (A23-A0) or a 4-byte address (A31-A0) and a dummy byte, and each bit is latched in on the rising edge of SCLK, then the memory contents are shifted out 4-bit per clock cycle from IO3, IO2, IO1 and IO0. The command sequence is shown in followed Figure12. The first byte addressed can be at any location. The address is automatically incremented to the next higher address after each byte of data is shifted out. The default read mode is 3-byte address mode, and the lower 128Mbit can be read with a single Quad Output Fast Read (6BH) command. By entering 4-byte address mode, or to set EN4B (S11) bit to 1, the higher 128Mbit can be read with a single Quad Output Fast Read (6BH) command.

**Figure12. Quad Output Fast Read Sequence Diagram**



Note: The device default is in 24-bit address mode. For 4-byte mode, the address length becomes 32-bit.

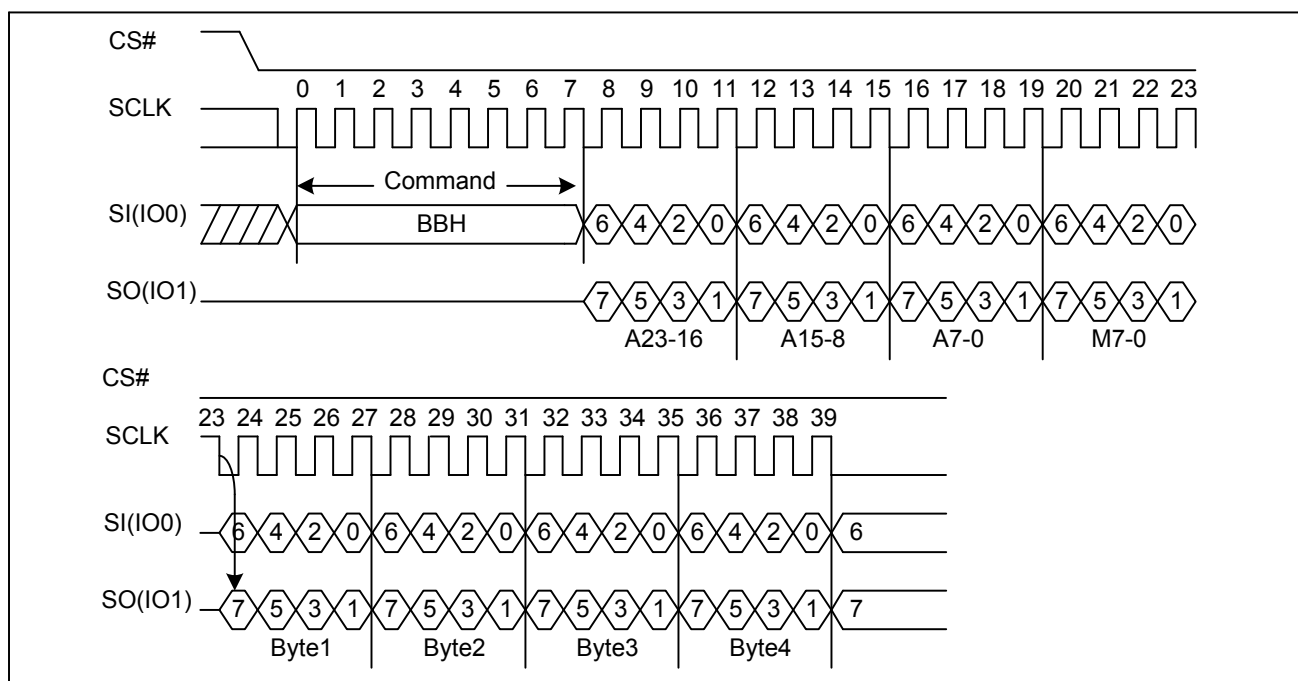
### 7.12. Dual I/O Fast Read (BBH)

The Dual I/O Fast Read command is similar to the Dual Output Fast Read command but with the capability to input the 3-byte address (A23-0) or a 4-byte address (A31-A0) and a “Continuous Read Mode” byte 2-bit per clock by SI and SO, and each bit is latched in on the rising edge of SCLK, then the memory contents are shifted out 2-bit per clock cycle from SI and SO. The command sequence is shown in followed Figure13. The first byte addressed can be at any location. The address is automatically incremented to the next higher address after each byte of data is shifted out. The default read mode is 3-byte address mode, and the lower 128Mbit can be read with a single Dual I/O Fast Read (BBH) command. By entering 4-byte address mode, or to set EN4B (S11) bit to 1, the higher 128Mbit can be read with a single Dual I/O Fast Read (BBH) command.

#### Dual I/O Fast Read with “Continuous Read Mode”

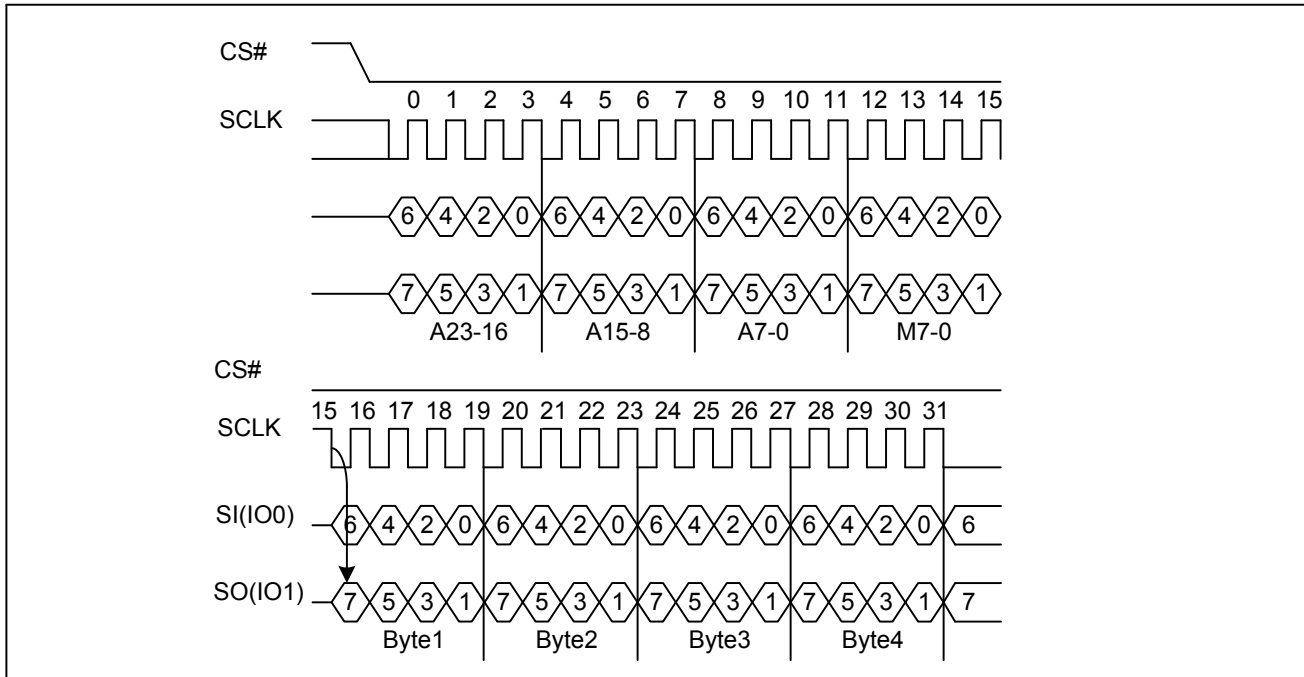
The Dual I/O Fast Read command can further reduce command overhead through setting the “Continuous Read Mode” bits (M7-0) after the input 3-byte address (A23-A0) or a 4-byte address (A31-A0). If the “Continuous Read Mode” bits (M5-4) = (1, 0), then the next Dual I/O Fast Read command (after CS# is raised and then lowered) does not require the BBH command code. The command sequence is shown in followed Figure13a. If the “Continuous Read Mode” bits (M5-4) do not equal (1, 0), the next command requires the first BBH command code, thus returning to normal operation.

**Figure13. Dual I/O Fast Read Sequence Diagram (M5-4≠ (1, 0))**



Note: The device default is in 24-bit address mode. For 4-byte mode, the address length becomes 32-bit.

Figure13a. Dual I/O Fast Read Sequence Diagram (M5-4= (1, 0))

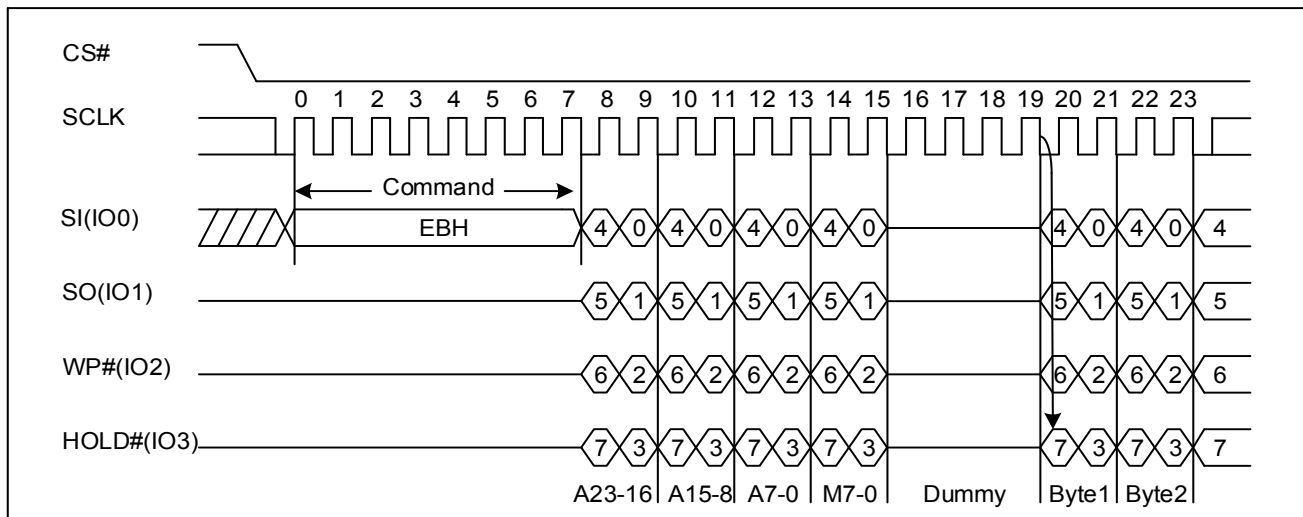


Note: The device default is in 24-bit address mode. For 4-byte mode, the address length becomes 32-bit.

**7.13. Quad I/O Fast Read (EBH)**

The Quad I/O Fast Read command is similar to the Dual I/O Fast Read command but with the capability to input the 3-byte address (A23-0) or a 4-byte address (A31-A0) and a “Continuous Read Mode” byte and 4-dummy clock 4-bit per clock by IO0, IO1, IO3, IO4, and each bit is latched in on the rising edge of SCLK, then the memory contents are shifted out 4-bit per clock cycle from IO0, IO1, IO2, IO3. The command sequence is shown in followed Figure14. The first byte addressed can be at any location. The address is automatically incremented to the next higher address after each byte of data is shifted out. The default read mode is 3-byte address mode, and the lower 128Mbit can be read with a single Quad I/O Fast Read (EBH) command. By entering 4-byte address mode, or to set EN4B (S11) bit to 1, the higher 128Mbit can be read with a single Quad I/O Fast Read (EBH) command. The Quad Enable bit (QE) of Status Register (S9) must be set to enable for the Quad I/O Fast read command.

**Figure14. Quad I/O Fast Read Sequence Diagram (M5-4# (1, 0))**



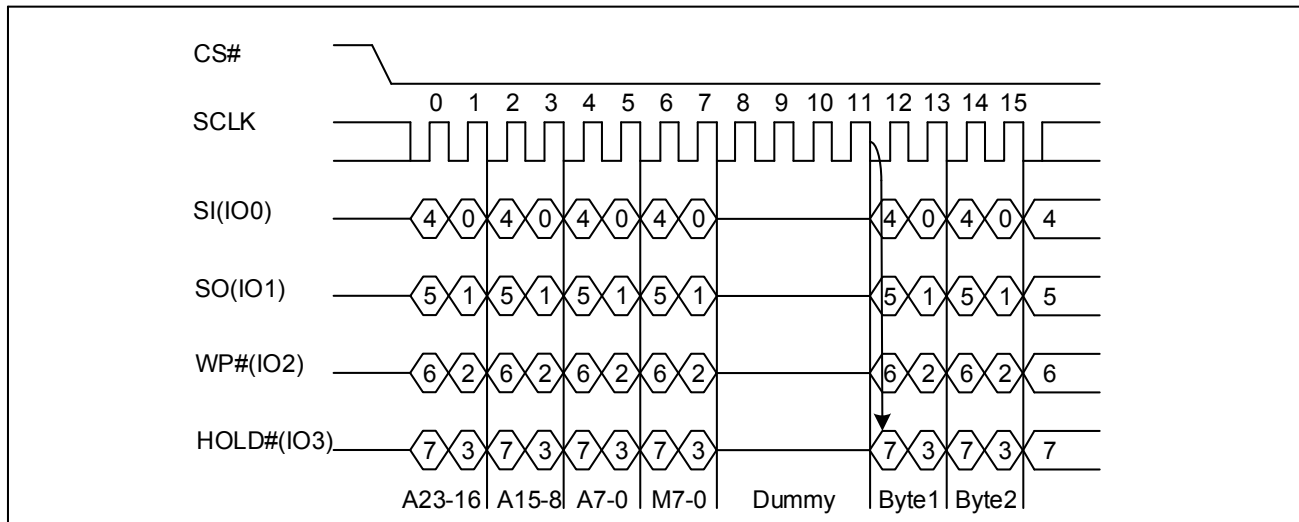
Note: The device default is in 24-bit address mode. For 4-byte mode, the address length becomes 32-bit.



**Quad I/O Fast Read with “Continuous Read Mode”**

The Quad I/O Fast Read command can further reduce command overhead through setting the “Continuous Read Mode” bits (M7-0) after the input 3-byte address (A23-A0) or a 4-byte address (A31-A0). If the “Continuous Read Mode” bits (M5-4) = (1, 0), then the next Quad I/O Fast Read command (after CS# is raised and then lowered) does not require the EBH command code. The command sequence is shown in followed Figure14a. If the “Continuous Read Mode” bits (M5-4) do not equal to (1, 0), the next command requires the first EBH command code, thus returning to normal operation.

**Figure14a. Quad I/O Fast Read Sequence Diagram (M5-4= (1, 0))**



Note: The device default is in 24-bit address mode. For 4-byte mode, the address length becomes 32-bit.

**Quad I/O Fast Read with “8/16/32/64-Byte Wrap Around” in Standard SPI mode**

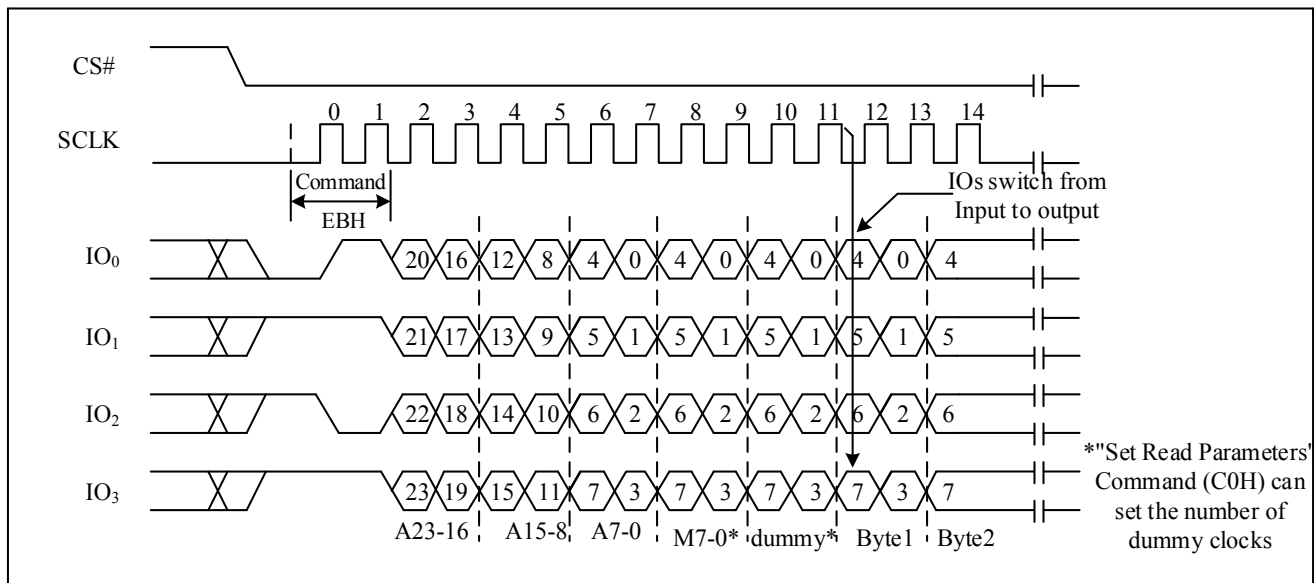
The Quad I/O Fast Read command can be used to access a specific portion within a page by issuing “Set Burst with Wrap” (77H) commands prior to EBH. The “Set Burst with Wrap” (77H) command can either enable or disable the “Wrap Around” feature for the following EBH commands. When “Wrap Around” is enabled, the data being accessed can be limited to either an 8/16/32/64-byte section of a 256-byte page. The output data starts at the initial address specified in the command, once it reaches the ending boundary of the 8/16/32/64-byte section, the output will wrap around the beginning boundary automatically until CS# is pulled high to terminate the command.

The Burst with Wrap feature allows applications that use cache to quickly fetch a critical address and then fill the cache afterwards within a fixed length (8/16/32/64-byte) of data without issuing multiple read commands. The “Set Burst with Wrap” command allows three “Wrap Bits” W6-W4 to be set. The W4 bit is used to enable or disable the “Wrap Around” operation while W6-W5 is used to specify the length of the wrap around section within a page.

**Quad I/O Fast Read (EBH) in QPI mode**

The Quad I/O Fast Read command is also supported in QPI mode. See Figure14b. In QPI mode, the number of dummy clocks is configured by the “Set Read Parameters (C0H)” command to accommodate a wide range application with different needs for either maximum Fast Read frequency or minimum data access latency. Depending on the Read Parameter Bits P[5:4] setting, the number of dummy clocks can be configured as either 4/6/8. In QPI mode, the “Continuous Read Mode” bits M7-M0 are also considered as dummy clocks. “Continuous Read Mode” feature is also available in QPI mode for Quad I/O Fast Read command. “Wrap Around” feature is not available in QPI mode for Quad I/O Fast Read command. To perform a read operation with fixed data length wrap around in QPI mode, a dedicated “Burst Read with Wrap” (0CH) command must be used.

**Figure14b. Quad I/O Fast Read Sequence Diagram (M5-4= (1, 0) QPI)**



Note: The device default is in 24-bit address mode. For 4-byte mode, the address length becomes 32-bit.

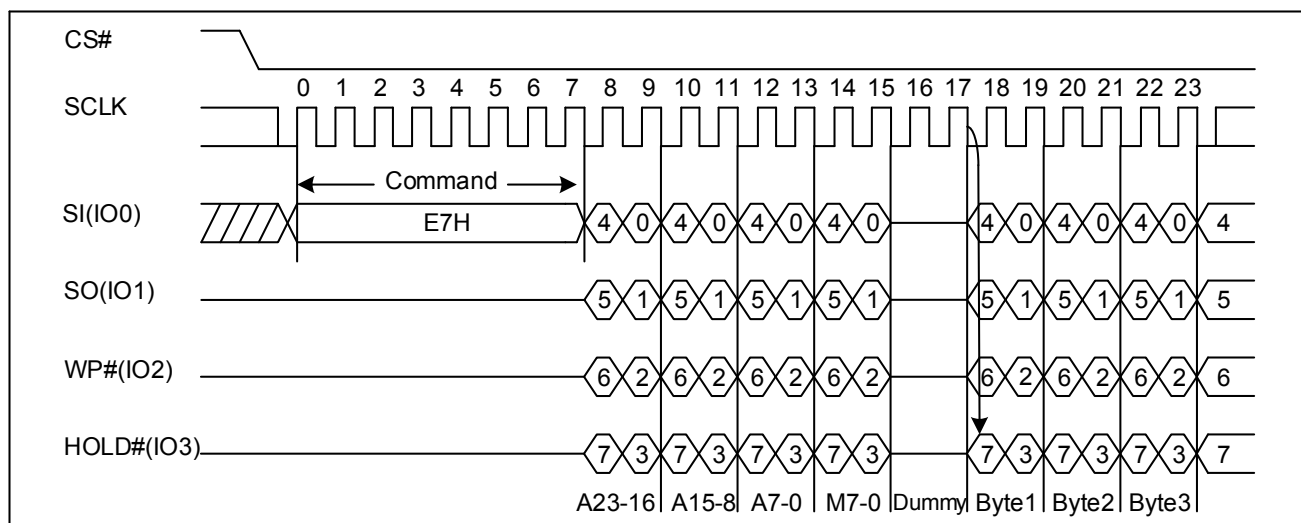
**7.14. Quad I/O Word Fast Read (E7H)**

The Quad I/O Word Fast Read command is similar to the Quad I/O Fast Read command except that the lowest address bit (A0) must equal 0 and only 2-dummy clock. The command sequence is shown in followed Figure15. The first byte addressed can be at any location. The address is automatically incremented to the next higher address after each byte of data is shifted out. The default read mode is 3-byte address mode, and the lower 128Mbit can be read with a single Quad I/O Word Fast Read (E7H) command. By entering 4-byte address mode, or to set EN4B (S11) bit to 1, the higher 128Mbit can be read with a single Quad I/O Word Fast Read (E7H) command. The Quad Enable bit (QE) of Status Register (S9) must be set to enable for the Quad I/O Word Fast read command.

**Quad I/O Word Fast Read with “Continuous Read Mode”**

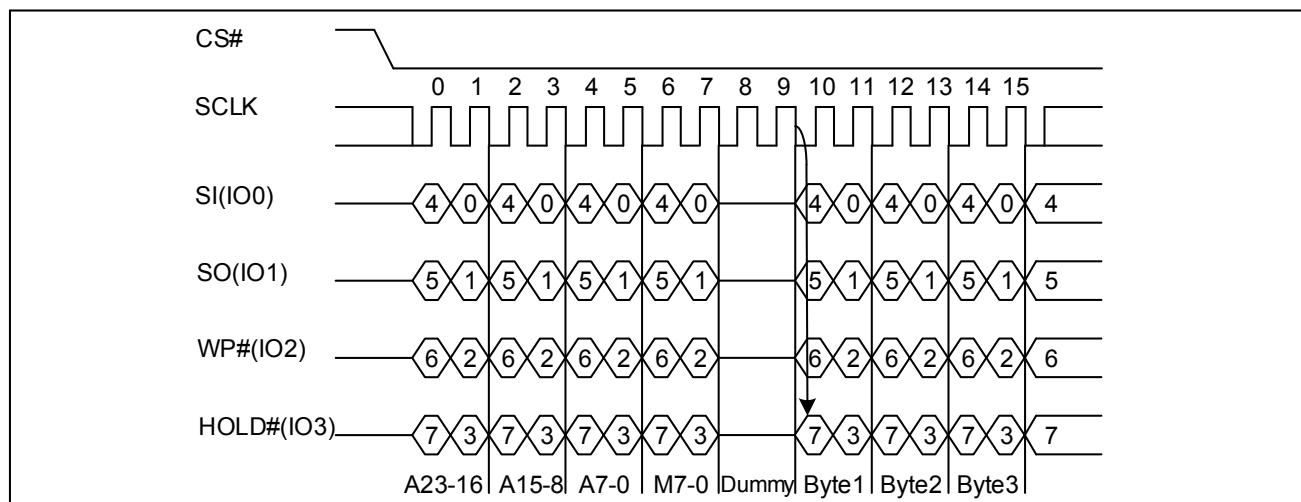
The Quad I/O Word Fast Read command can further reduce command overhead through setting the “Continuous Read Mode” bits (M7-0) after the input 3-byte address (A23-A0) or a 4-byte address (A31-A0). If the “Continuous Read Mode” bits (M5-4) = (1, 0), then the next Quad I/O Word Fast Read command (after CS# is raised and then lowered) does not require the E7H command code. The command sequence is shown in followed Figure15. If the “Continuous Read Mode” bits (M5-4) do not equal to (1, 0), the next command requires the first E7H command code, thus returning to normal operation.

**Figure15. Quad I/O Word Fast Read Sequence Diagram (M5-4≠ (1, 0))**



Note: The device default is in 24-bit address mode. For 4-byte mode, the address length becomes 32-bit.

**Figure15a. Quad I/O Word Fast Read Sequence Diagram (M5-4= (1, 0))**



Note: The device default is in 24-bit address mode. For 4-byte mode, the address length becomes 32-bit.

**Quad I/O Word Fast Read with “8/16/32/64-Byte Wrap Around” in Standard SPI mode**

The Quad I/O Word Fast Read command can be used to access a specific portion within a page by issuing “Set Burst with Wrap” (77H) commands prior to E7H. The “Set Burst with Wrap” (77H) command can either enable or disable the “Wrap Around” feature for the following E7H commands. When “Wrap Around” is enabled, the data being accessed can be limited to either an 8/16/32/64-byte section of a 256-byte page. The output data starts at the initial address specified in the command, once it reaches the ending boundary of the 8/16/32/64-byte section, the output will wrap around the beginning boundary automatically until CS# is pulled high to terminate the command.

The Burst with Wrap feature allows applications that use cache to quickly fetch a critical address and then fill the cache afterwards within a fixed length (8/16/32/64-byte) of data without issuing multiple read commands. The “Set Burst with Wrap” command allows three “Wrap Bits” W6-W4 to be set. The W4 bit is used to enable or disable the “Wrap Around” operation while W6-W5 is used to specify the length of the wrap around section within a page.

**7.15. Set Burst with Wrap (77H)**

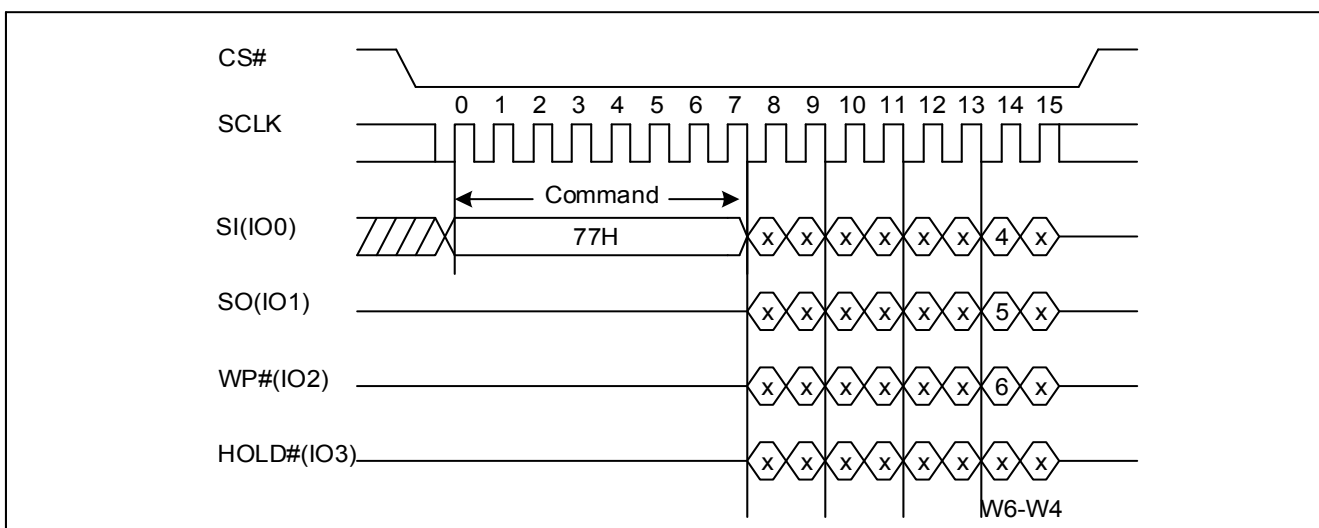
The Set Burst with Wrap command is used in conjunction with “Quad I/O Fast Read” and “Quad I/O Word Fast Read” command to access a fixed length of 8/16/32/64-byte section within a 256-byte page.

The Set Burst with Wrap command sequence: CS# goes low → Send Set Burst with Wrap command → Send 24 dummy bits → Send 8 bits “Wrap bits” → CS# goes high.

W6,W5	W4=0		W4=1 (default)	
	Wrap Around	Wrap Length	Wrap Around	Wrap Length
0, 0	Yes	8-byte	No	N/A
0, 1	Yes	16-byte	No	N/A
1, 0	Yes	32-byte	No	N/A
1, 1	Yes	64-byte	No	N/A

If the W6-W4 bits are set by the Set Burst with Wrap command, all the following “Quad I/O Fast Read” and “Quad I/O Word Fast Read” command will use the W6-W4 setting to access the 8/16/32/64-byte section within any page. To exit the “Wrap Around” function and return to normal read operation, another Set Burst with Wrap command should be issued to set W4=1. In QPI mode, the “Burst Read with Wrap (0CH)” command should be used to perform the Read Operation with “Wrap Around” feature. The Wrap Length set by W5-W6 in Standard SPI mode is still valid in QPI mode and can also be re-configured by “Set Read Parameters (C0H)” command.

**Figure16. Set Burst with Wrap Sequence Diagram**



### 7.16. Page Program (PP) (02H)

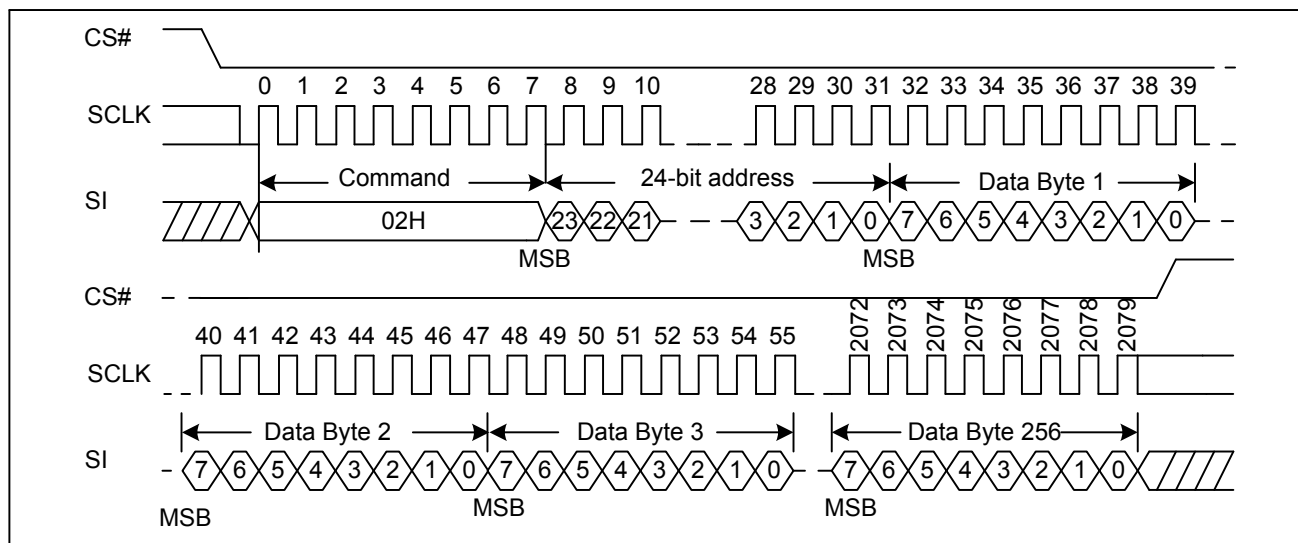
The Page Program (PP) command is for programming the memory. A Write Enable (WREN) command must previously have been executed to set the Write Enable Latch (WEL) bit before sending the Page Program command.

The Page Program (PP) command is entered by driving CS# Low, followed by the command code, three address bytes and at least one data byte on SI. If the 8 least significant address bits (A7-A0) are not all zero, all transmitted data that goes beyond the end of the current page are programmed from the start address of the same page (from the address whose 8 least significant bits (A7-A0) are all zero). CS# must be driven low for the entire duration of the sequence. The Page Program command sequence: CS# goes low → sending Page Program command → 3-byte address or 4-byte address on SI → at least 1 byte data on SI → CS# goes high. The command sequence is shown in Figure 17. If more than 256 bytes are sent to the device, previously latched data are discarded and the last 256 data bytes are guaranteed to be programmed correctly within the same page. If less than 256 data bytes are sent to device, they are correctly programmed at the requested addresses without having any effects on the other bytes of the same page. CS# must be driven high after the eighth bit of the last data byte has been latched in; otherwise the Page Program (PP) command is not executed.

As soon as CS# is driven high, the self-timed Page Program cycle (whose duration is  $t_{PP}$ ) is initiated. While the Page Program cycle is in progress, the Status Register may be read to check the value of the Write in Progress (WIP) bit. The Write in Progress (WIP) bit is 1 during the self-timed Page Program cycle, and is 0 when it is completed. At some unspecified time before the cycle is completed, the Write Enable Latch (WEL) bit is reset.

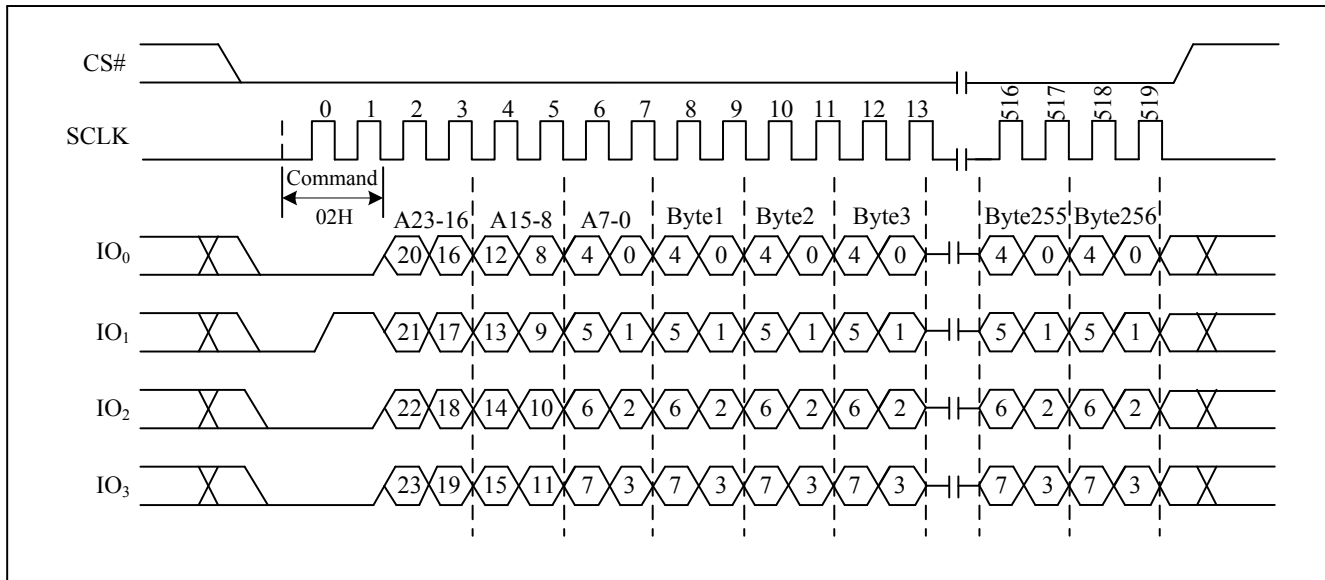
A Page Program (PP) command applied to a page which is protected by the Block Protect (BP4, BP3, BP2, BP1, and BP0) is not executed.

**Figure 17. Page Program Sequence Diagram**



Note: The device default is in 24-bit address mode. For 4-byte mode, the address length becomes 32-bit.

Figure17a. Page Program Sequence Diagram (QPI)



Note: The device default is in 24-bit address mode. For 4-byte mode, the address length becomes 32-bit.

**7.17. Quad Page Program (32H)**

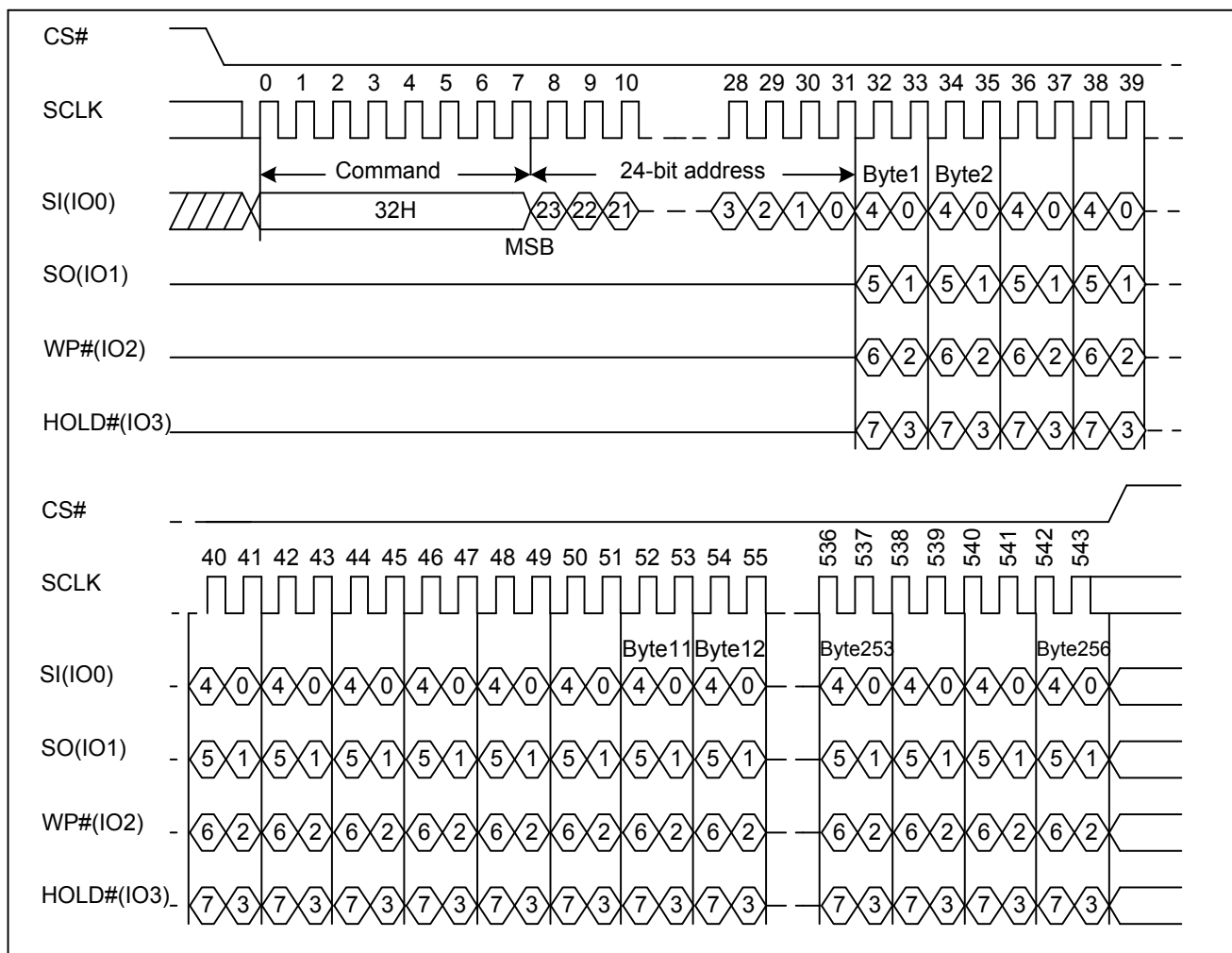
The Quad Page Program command is for programming the memory using four pins: IO0, IO1, IO2, and IO3. To use Quad Page Program the Quad enable in status register Bit9 must be set (QE=1). A Write Enable (WREN) command must previously have been executed to set the Write Enable Latch (WEL) bit before sending the Page Program command. The quad Page Program command is entered by driving CS# Low, followed by the command code (32H), three or four address bytes and at least one data byte on IO pins.

The command sequence is shown in Figure18. If more than 256 bytes are sent to the device, previously latched data are discarded and the last 256 data bytes are guaranteed to be programmed correctly within the same page. If less than 256 data bytes are sent to device, they are correctly programmed at the requested addresses without having any effects on the other bytes of the same page. CS# must be driven high after the eighth bit of the last data byte has been latched in; otherwise the Quad Page Program (PP) command is not executed.

As soon as CS# is driven high, the self-timed Quad Page Program cycle (whose duration is  $t_{PP}$ ) is initiated. While the Quad Page Program cycle is in progress, the Status Register may be read to check the value of the Write In Progress (WIP) bit. The Write in Progress (WIP) bit is 1 during the self-timed Quad Page Program cycle, and is 0 when it is completed. At some unspecified time before the cycle is completed, the Write Enable Latch (WEL) bit is reset.

A Quad Page Program command applied to a page which is protected by the Block Protect (BP4, BP3, BP2, BP1, and BP0) is not executed.

**Figure18. Quad Page Program Sequence Diagram**



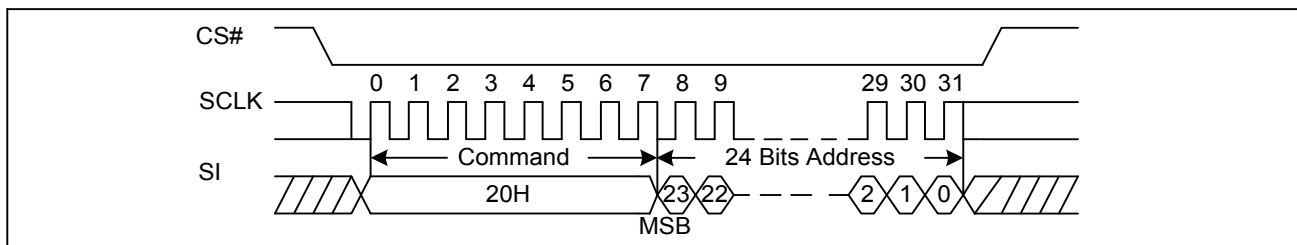
Note: The device default is in 24-bit address mode. For 4-byte mode, the address length becomes 32-bit.

**7.18. Sector Erase (SE) (20H)**

The Sector Erase (SE) command is erased the all data of the chosen sector. A Write Enable (WREN) command must previously have been executed to set the Write Enable Latch (WEL) bit. The Sector Erase (SE) command is entered by driving CS# low, followed by the command code, and 3- byte address or 4-byte address on SI. Any address inside the sector is a valid address for the Sector Erase (SE) command. CS# must be driven low for the entire duration of the sequence.

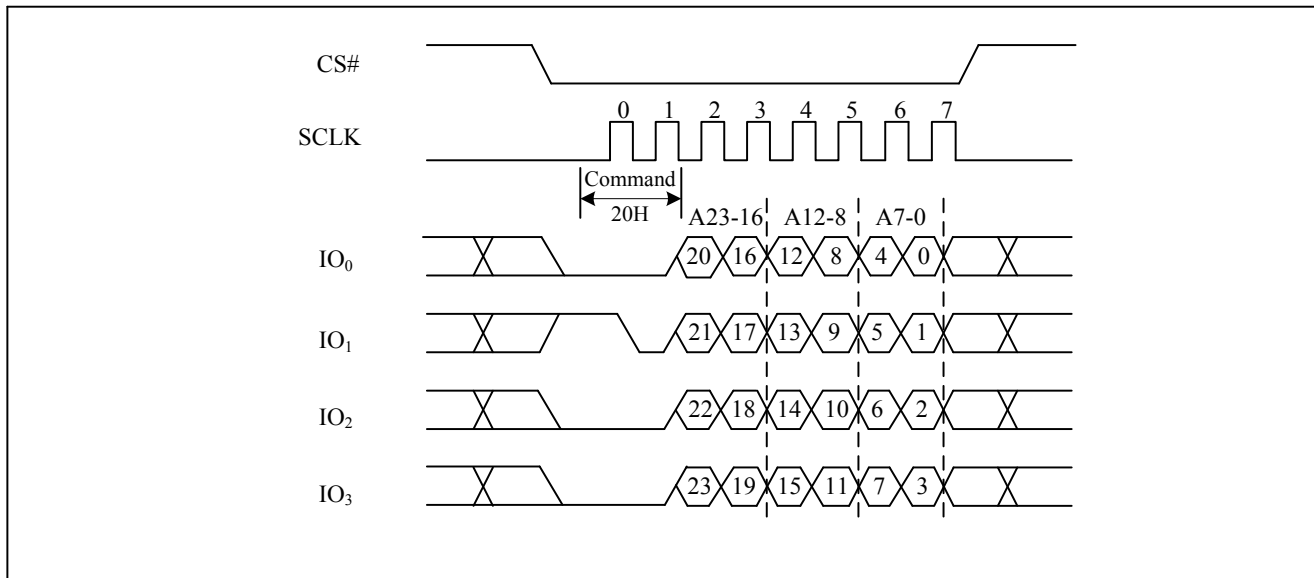
The Sector Erase command sequence: CS# goes low → sending Sector Erase command → 3-byte address or 4-byte address on SI → CS# goes high. The command sequence is shown in Figure19. CS# must be driven high after the eighth bit of the last address byte has been latched in; otherwise the Sector Erase (SE) command is not executed. As soon as CS# is driven high, the self-timed Sector Erase cycle (whose duration is  $t_{SE}$ ) is initiated. While the Sector Erase cycle is in progress, the Status Register may be read to check the value of the Write in Progress (WIP) bit. The Write in Progress (WIP) bit is 1 during the self-timed Sector Erase cycle, and is 0 when it is completed. At some unspecified time before the cycle is completed, the Write Enable Latch (WEL) bit is reset. A Sector Erase (SE) command applied to a sector which is protected by the Block Protect (BP4, BP3, BP2, BP1, and BP0) bit (see Table1&1a) is not executed.

**Figure19. Sector Erase Sequence Diagram**



Note: The device default is in 24-bit address mode. For 4-byte mode, the address length becomes 32-bit.

**Figure19a. Sector Erase Sequence Diagram (QPI)**



Note: The device default is in 24-bit address mode. For 4-byte mode, the address length becomes 32-bit.

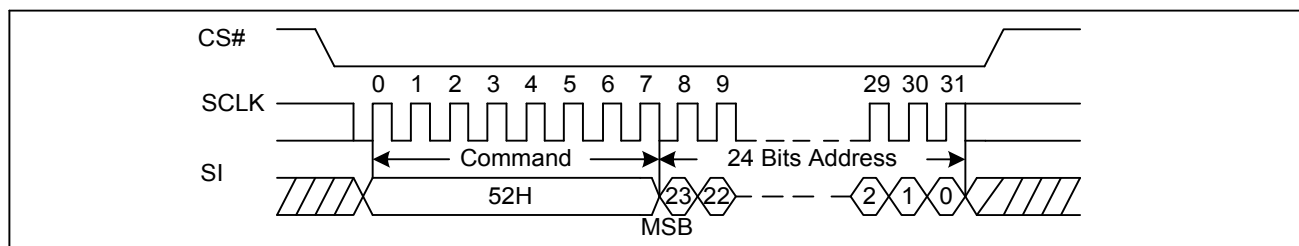


### 7.19. 32KB Block Erase (BE) (52H)

The 32KB Block Erase (BE) command is erased the all data of the chosen block. A Write Enable (WREN) command must previously have been executed to set the Write Enable Latch (WEL) bit. The 32KB Block Erase (BE) command is entered by driving CS# low, followed by the command code, and 3-byte address or 4-byte address on SI. Any address inside the block is a valid address for the 32KB Block Erase (BE) command. CS# must be driven low for the entire duration of the sequence.

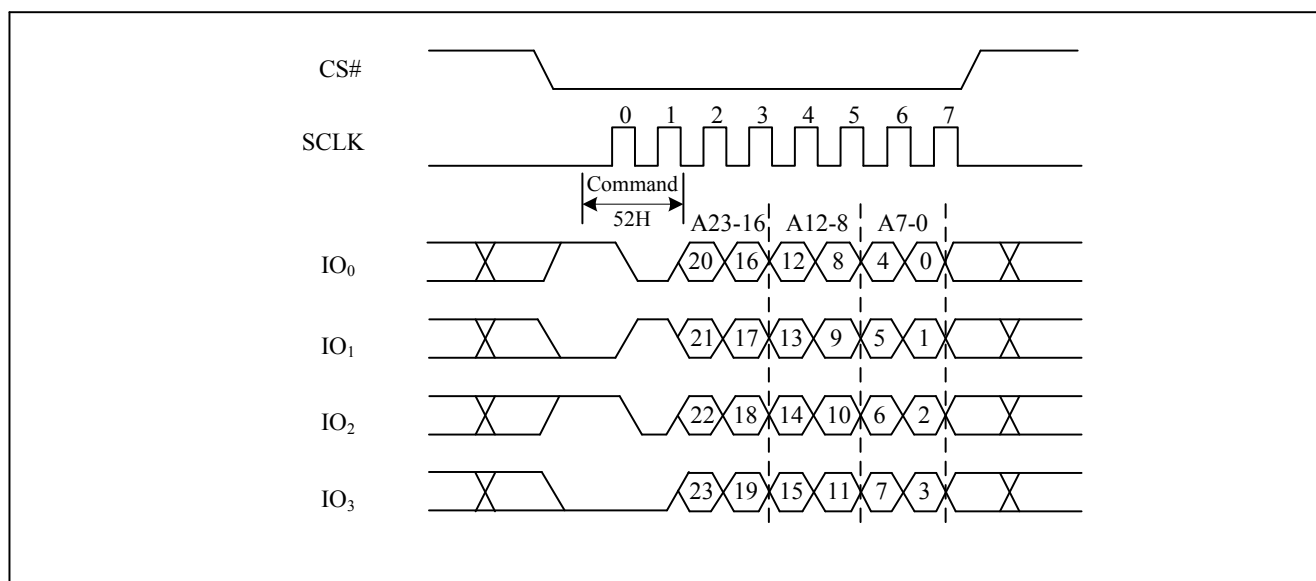
The 32KB Block Erase command sequence: CS# goes low → sending 32KB Block Erase command → 3-byte address or 4-byte address on SI → CS# goes high. The command sequence is shown in Figure20. CS# must be driven high after the eighth bit of the last address byte has been latched in; otherwise the 32KB Block Erase (BE) command is not executed. As soon as CS# is driven high, the self-timed Block Erase cycle (whose duration is  $t_{SE}$ ) is initiated. While the Block Erase cycle is in progress, the Status Register may be read to check the value of the Write in Progress (WIP) bit. The Write in Progress (WIP) bit is 1 during the self-timed Block Erase cycle, and is 0 when it is completed. At some unspecified time before the cycle is completed, the Write Enable Latch (WEL) bit is reset. A 32KB Block Erase (BE) command applied to a block which is protected by the Block Protect (BP4, BP3, BP2, BP1, and BP0) bits (see Table1&1a) is not executed.

**Figure20. 32KB Block Erase Sequence Diagram**



Note: The device default is in 24-bit address mode. For 4-byte mode, the address length becomes 32-bit.

**Figure20a. 32KB Block Erase Sequence Diagram (QPI)**



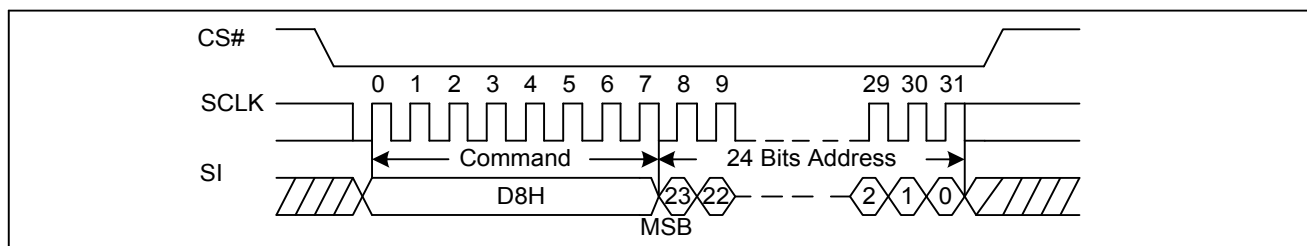
Note: The device default is in 24-bit address mode. For 4-byte mode, the address length becomes 32-bit.

**7.20. 64KB Block Erase (BE) (D8H)**

The 64KB Block Erase (BE) command is erased the all data of the chosen block. A Write Enable (WREN) command must previously have been executed to set the Write Enable Latch (WEL) bit. The 64KB Block Erase (BE) command is entered by driving CS# low, followed by the command code, and 3-byte address or 4-byte address on SI. Any address inside the block is a valid address for the 64KB Block Erase (BE) command. CS# must be driven low for the entire duration of the sequence.

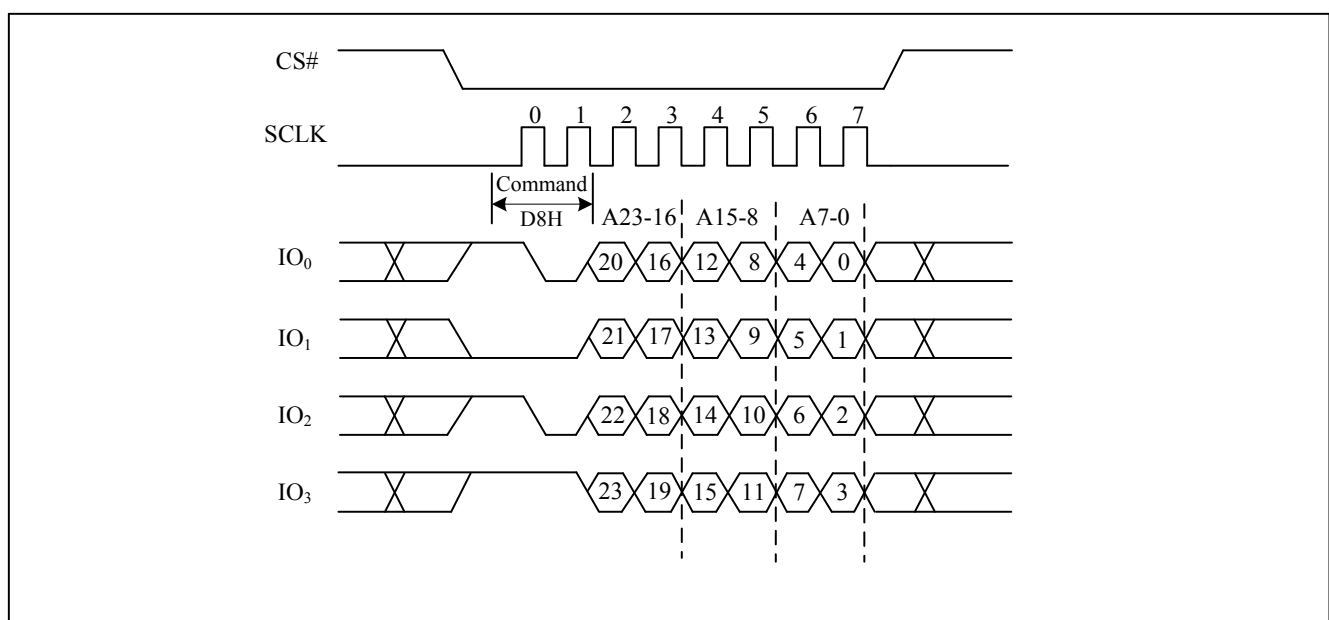
The 64KB Block Erase command sequence: CS# goes low → sending 64KB Block Erase command → 3-byte address or 4-byte address on SI → CS# goes high. The command sequence is shown in Figure21. CS# must be driven high after the eighth bit of the last address byte has been latched in; otherwise the 64KB Block Erase (BE) command is not executed. As soon as CS# is driven high, the self-timed Block Erase cycle (whose duration is  $t_{SE}$ ) is initiated. While the Block Erase cycle is in progress, the Status Register may be read to check the value of the Write in Progress (WIP) bit. The Write in Progress (WIP) bit is 1 during the self-timed Block Erase cycle, and is 0 when it is completed. At some unspecified time before the cycle is completed, the Write Enable Latch (WEL) bit is reset. A 64KB Block Erase (BE) command applied to a block which is protected by the Block Protect (BP4, BP3, BP2, BP1, and BP0) bits (see Table1&1a) is not executed.

**Figure21. 64KB Block Erase Sequence Diagram**



Note: The device default is in 24-bit address mode. For 4-byte mode, the address length becomes 32-bit.

**Figure21a. 64KB Block Erase Sequence Diagram (QPI)**



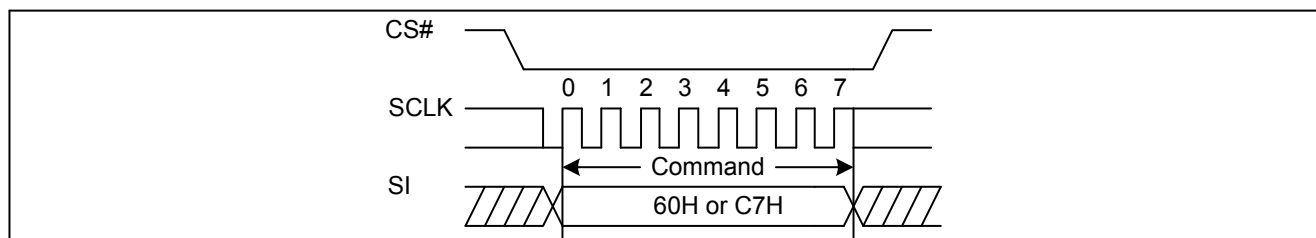
Note: The device default is in 24-bit address mode. For 4-byte mode, the address length becomes 32-bit.

### 7.21. Chip Erase (CE) (60/C7H)

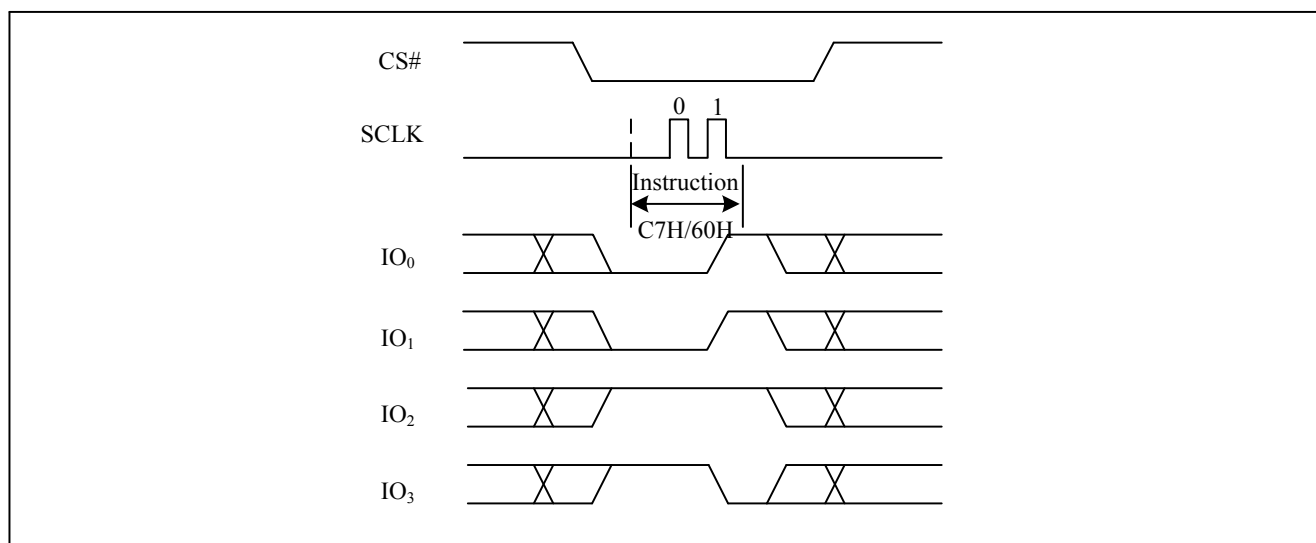
The Chip Erase (CE) command is erased the all data of the chip. A Write Enable (WREN) command must previously have been executed to set the Write Enable Latch (WEL) bit. The Chip Erase (CE) command is entered by driving CS# Low, followed by the command code on Serial Data Input (SI). CS# must be driven Low for the entire duration of the sequence.

The Chip Erase command sequence: CS# goes low → sending Chip Erase command → CS# goes high. The command sequence is shown in Figure22. CS# must be driven high after the eighth bit of the command code has been latched in; otherwise the Chip Erase command is not executed. As soon as CS# is driven high, the self-timed Chip Erase cycle (whose duration is  $t_{CE}$ ) is initiated. While the Chip Erase cycle is in progress, the Status Register may be read to check the value of the Write in Progress (WIP) bit. The Write in Progress (WIP) bit is 1 during the self-timed Chip Erase cycle, and is 0 when it is completed. At some unspecified time before the cycle is completed, the Write Enable Latch (WEL) bit is reset. The Chip Erase (CE) command is executed if the Block Protect (BP2, BP1, and BP0) bits are 0 and CMP=0 or the Block Protect (BP2, BP1, and BP0) bits are 1 and CMP=1. The Chip Erase (CE) command is ignored if one or more sectors are protected.

**Figure22. Chip Erase Sequence Diagram**



**Figure22a. Chip Erase Sequence Diagram (QPI)**

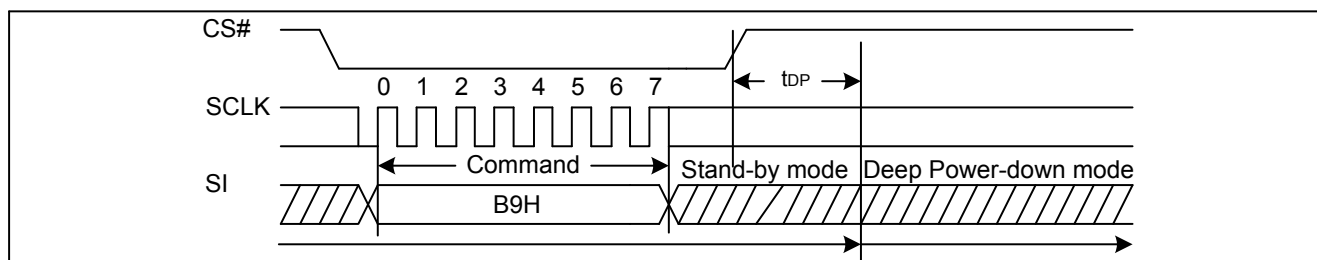


**7.22. Deep Power-Down (DP) (B9H)**

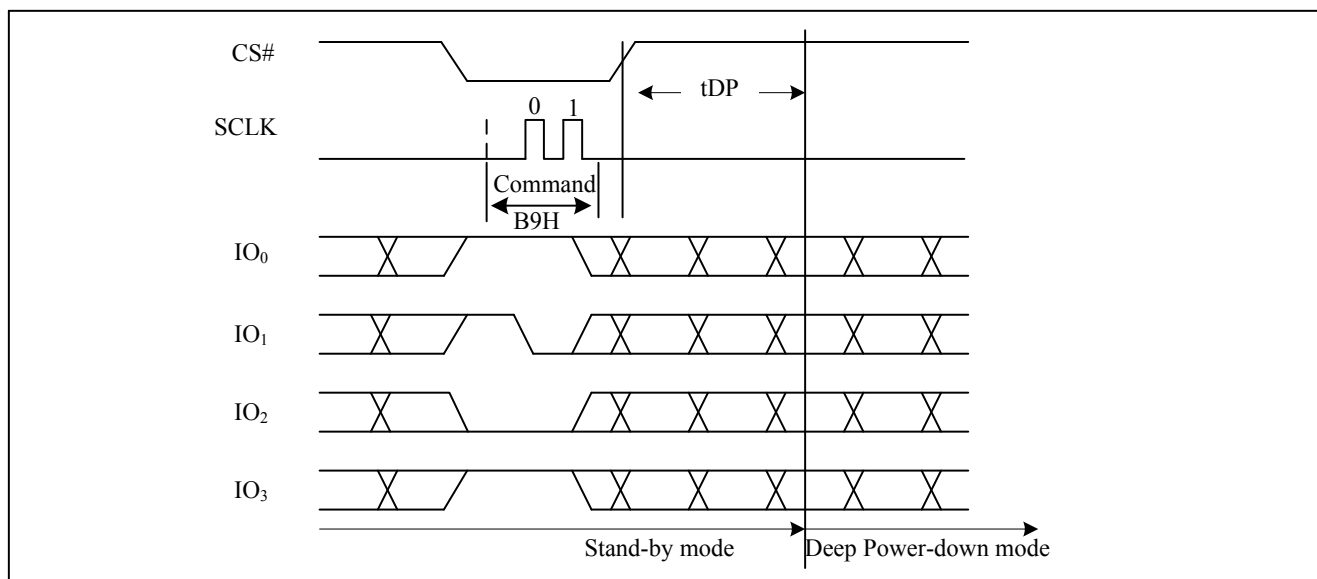
Executing the Deep Power-Down (DP) command is the only way to put the device in the lowest consumption mode (the Deep Power-Down Mode). It can also be used as an extra software protection mechanism, while the device is not in active use, since in this mode, the device ignores all Write, Program and Erase commands. Driving CS# high deselects the device, and puts the device in the Standby Mode (if there is no internal cycle currently in progress). But this mode is not the Deep Power-Down Mode. The Deep Power-Down Mode can only be entered by executing the Deep Power-Down (DP) command. Once the device has entered the Deep Power-Down Mode, all commands are ignored except the Release from Deep Power-Down and Read Device ID (RDI) c(ABH) or Enable Reset (66H) and Reset (99H) commands. These commands can release the device from this mode. The Release from Deep Power-Down and Read Device ID (RDI) command releases the device from deep power down mode, also allows the Device ID of the device to be output on SO.

The Deep Power-Down Mode automatically stops at Power-Down, and the device is in the Standby Mode after Power-Up. The Deep Power-Down command sequence: CS# goes low → sending Deep Power-Down command → CS# goes high. The command sequence is shown in Figure23. CS# must be driven high after the eighth bit of the command code has been latched in; otherwise the Deep Power-Down (DP) command is not executed. As soon as CS# is driven high, it requires a delay of  $t_{DP}$  before the supply current is reduced to  $I_{CC2}$  and the Deep Power-Down Mode is entered. Any Deep Power-Down (DP) command, while an Erase, Program or Write cycle is in progress, is rejected without having any effects on the cycle that is in progress.

**Figure23. Deep Power-Down Sequence Diagram**



**Figure23a. Deep Power-Down Sequence Diagram (QPI)**



**7.23. Release from Deep Power-Down and Read Device ID (RDI) (ABH)**

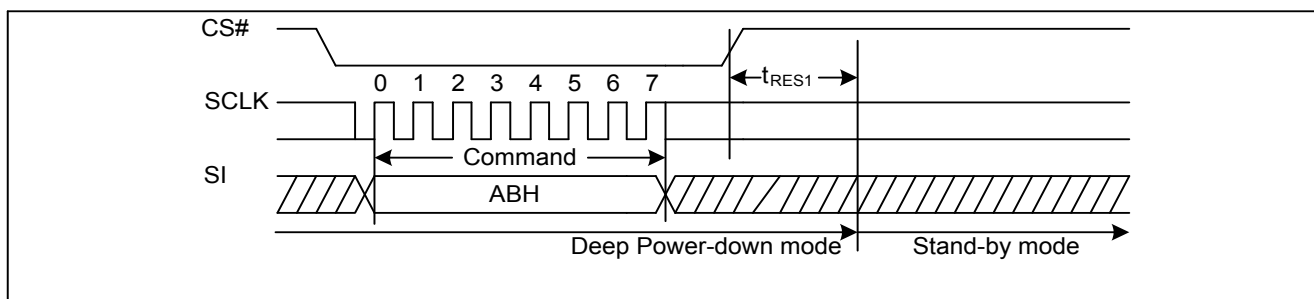
The Release from Power-Down and Read Device ID command is a multi-purpose command. It can be used to release the device from the Power-Down state or obtain the devices electronic identification (ID) number.

To release the device from the Power-Down state, the command is issued by driving the CS# pin low, shifting the instruction code “ABH” and driving CS# high as shown in Figure24. Release from Power-Down will take the time duration of  $t_{RES1}$  (See AC Characteristics) before the device will resume normal operation and other command are accepted. The CS# pin must remain high during the  $t_{RES1}$  time duration.

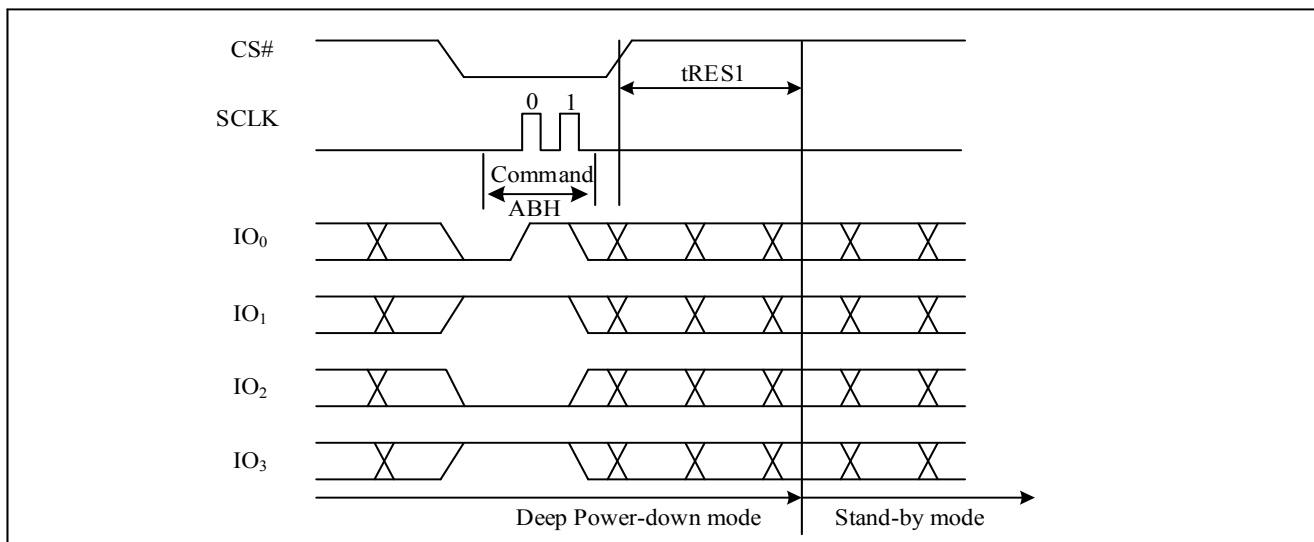
When used only to obtain the Device ID while not in the Power-Down state, the command is initiated by driving the CS# pin low and shifting the instruction code “ABH” followed by 3-dummy byte. The Device ID bits are then shifted out on the falling edge of SCLK with most significant bit (MSB) first as shown in Figure24. The Device ID value for the GD25LE256D is listed in Manufacturer and Device Identification table. The Device ID can be read continuously. The command is completed by driving CS# high.

When used to release the device from the Power-Down state and obtain the Device ID, the command is the same as previously described, and shown in Figure25, except that after CS# is driven high it must remain high for a time duration of  $t_{RES2}$  (See AC Characteristics). After this time duration the device will resume normal operation and other command will be accepted. If the Release from Power-Down / Device ID command is issued while an Erase, Program or Write cycle is in process (when WIP equal 1) the command is ignored and will not have any effects on the current cycle.

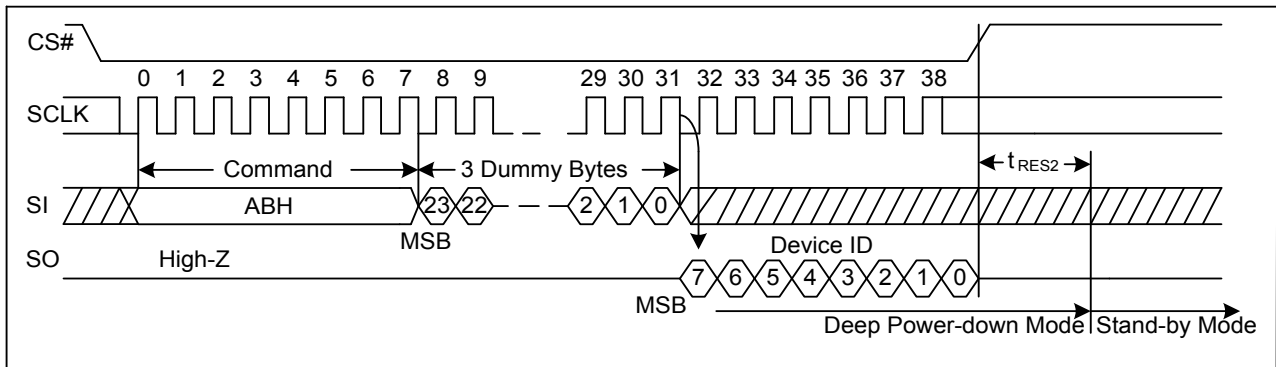
**Figure24. Release Power-Down Sequence Diagram**



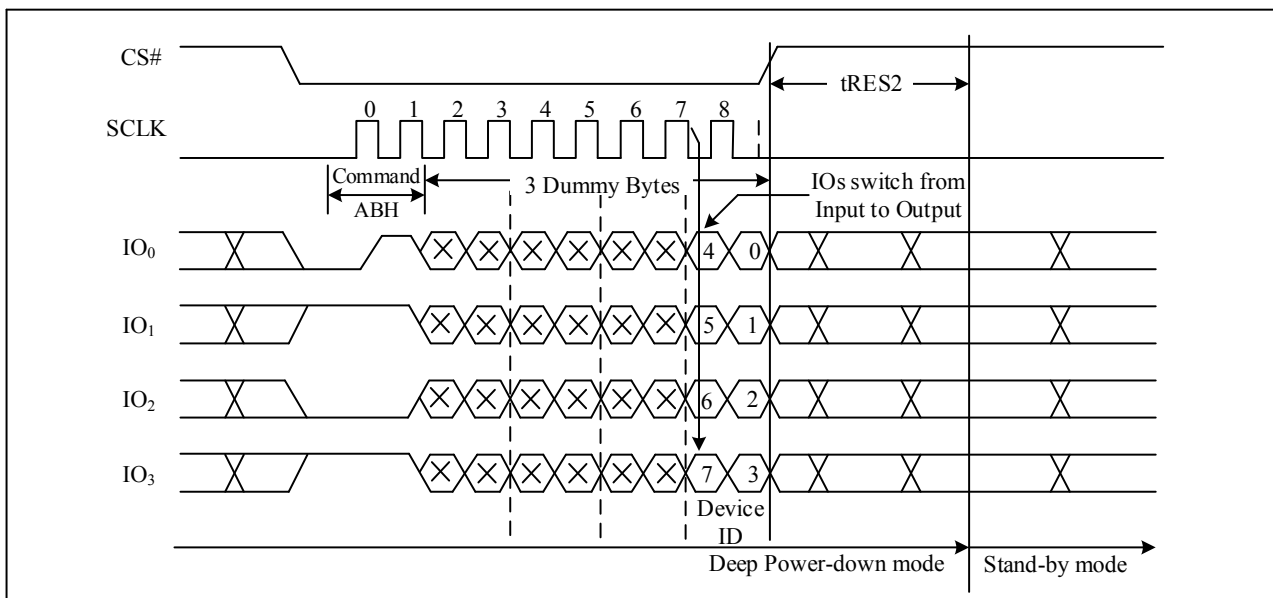
**Figure24a. Release Power-Down Sequence Diagram (QPI)**



**Figure25. Release Power-Down/Read Device ID Sequence Diagram**



**Figure25a. Release Power-Down/Read Device ID Sequence Diagram (QPI)**

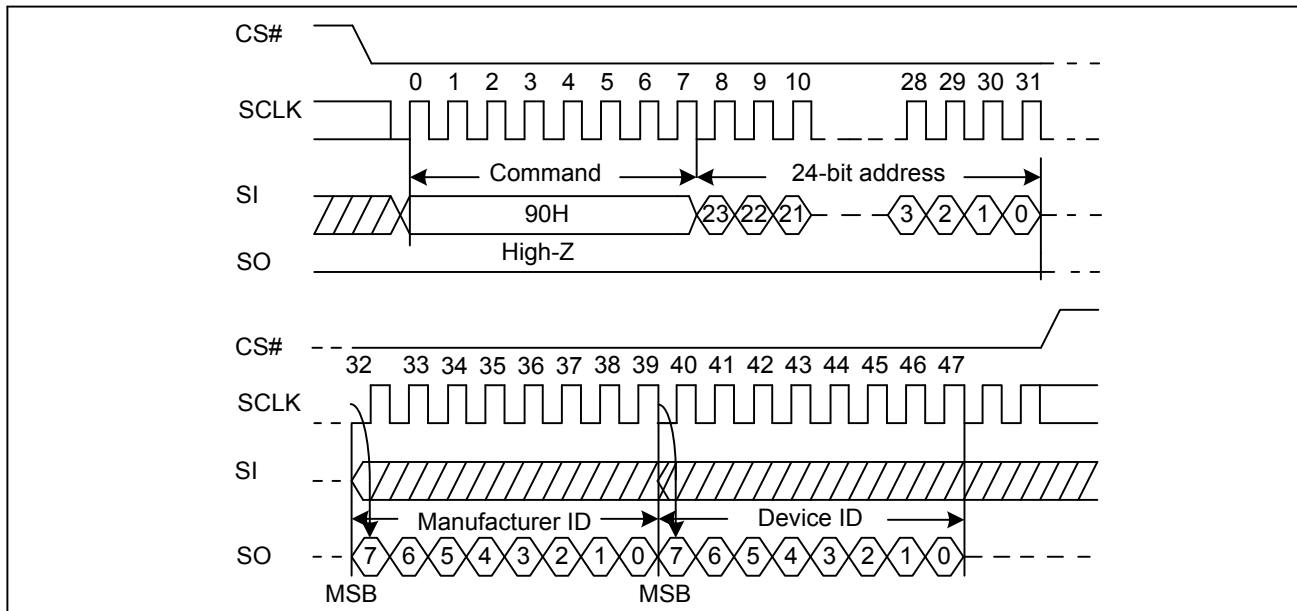


**7.24. Read Manufacturer ID/ Device ID (REMS) (90H)**

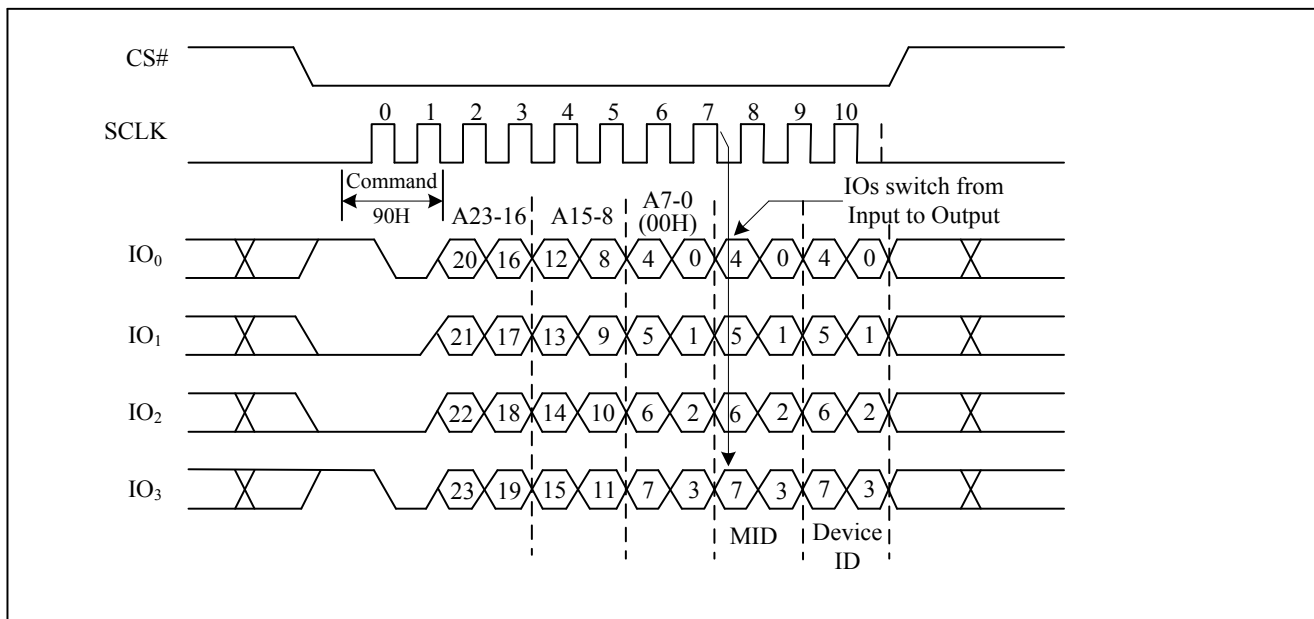
The Read Manufacturer/Device ID command is an alternative to the Release from Power-Down / Device ID command that provides both the JEDEC assigned Manufacturer ID and the specific Device ID.

The command is initiated by driving the CS# pin low and shifting the command code "90H" followed by a 24-bit address (A23-A0) of 000000H. After which, the Manufacturer ID and the Device ID are shifted out on the falling edge of SCLK with most significant bit (MSB) first as shown in Figure26. If the 24-bit address is initially set to 000001H, the Device ID will be read first.

**Figure26. Read Manufacturer ID/ Device ID Sequence Diagram**



**Figure26a. Read Manufacturer ID/ Device ID Sequence Diagram (QPI)**

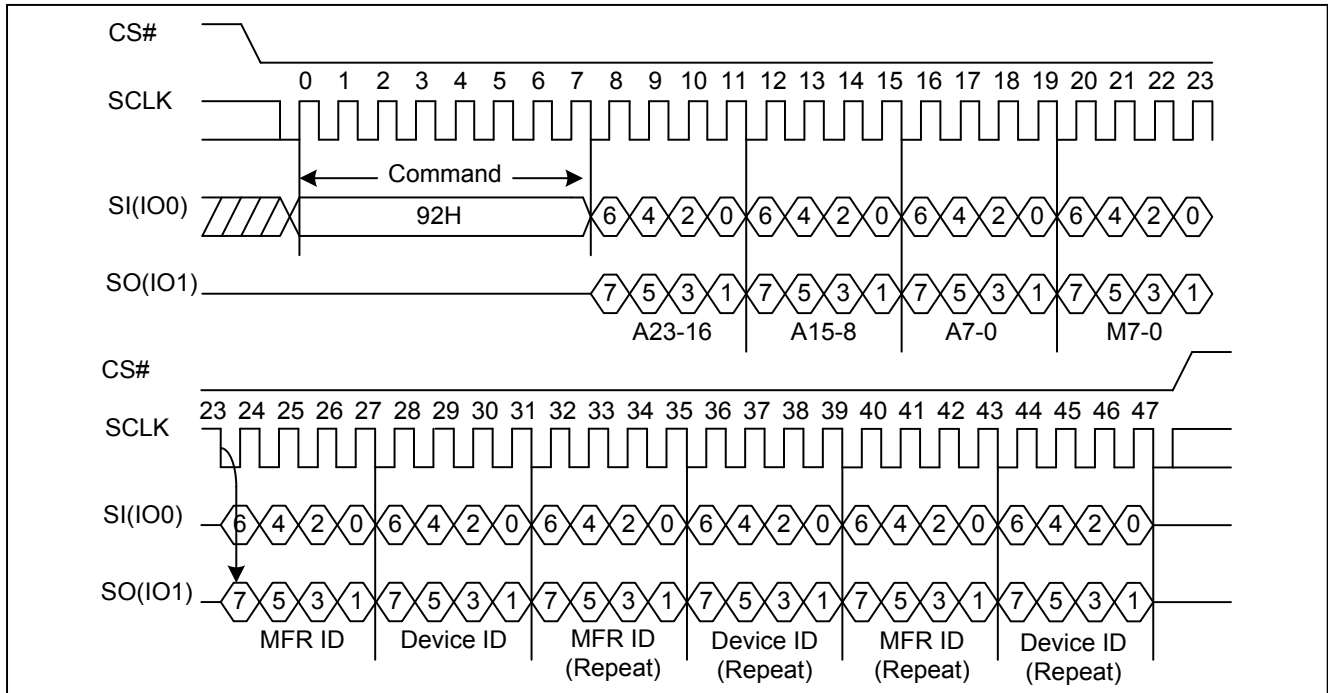


**7.25. Read Manufacture ID/ Device ID Dual I/O (92H)**

The Read Manufacturer/Device ID Dual I/O command is an alternative to the Release from Power-Down / Device ID command that provides both the JEDEC assigned Manufacturer ID and the specific Device ID by dual I/O.

The command is initiated by driving the CS# pin low and shifting the command code "92H" followed by a 24-bit address (A23-A0) of 000000H. After which, the Manufacturer ID and the Device ID are shifted out on the falling edge of SCLK with most significant bit (MSB) first as shown in Figure27. If the 24-bit address is initially set to 000001H, the Device ID will be read first.

**Figure27. Read Manufacture ID/ Device ID Dual I/O Sequence Diagram**



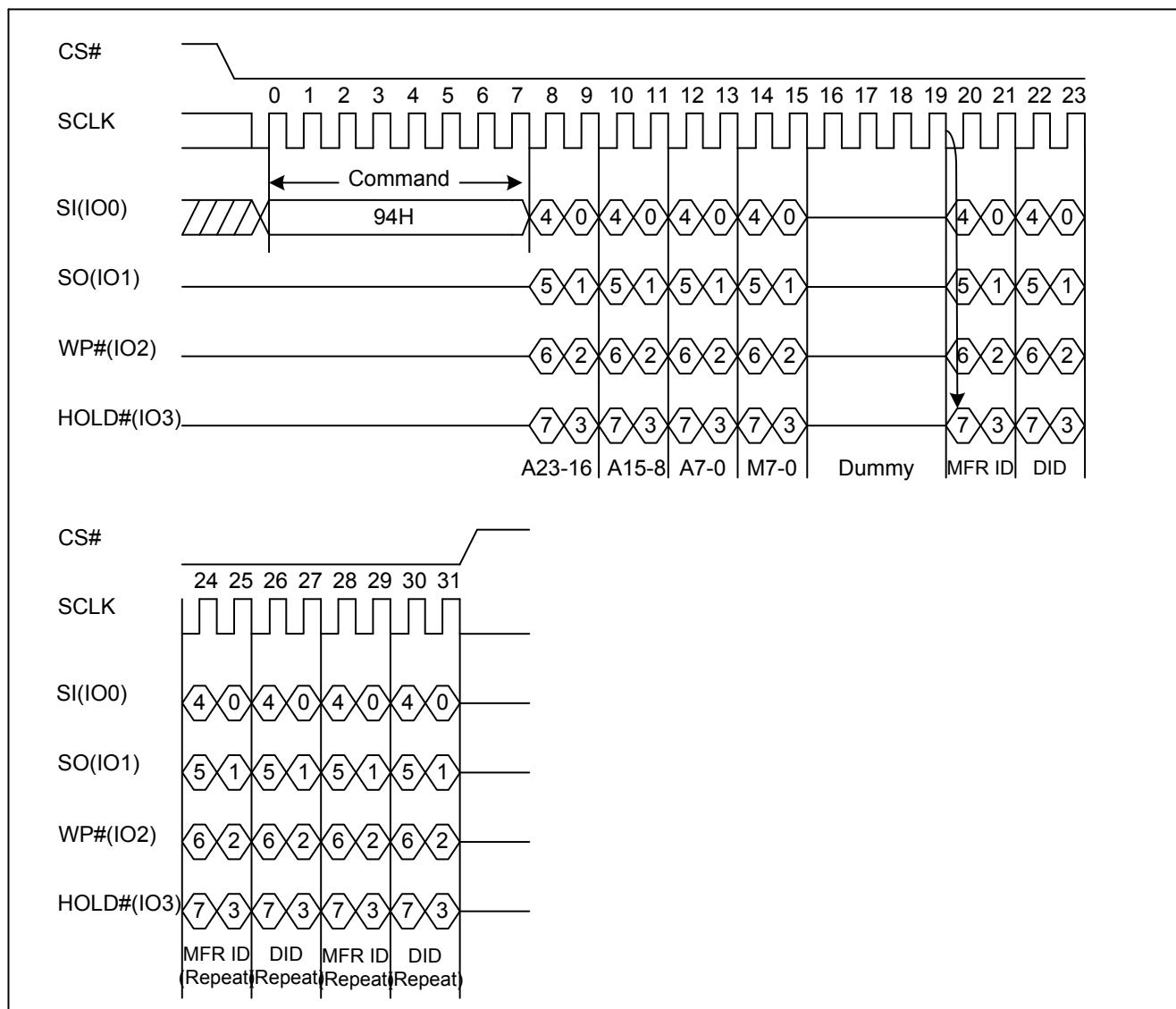


**7.26. Read Manufacture ID/ Device ID Quad I/O (94H)**

The Read Manufacturer/Device ID Quad I/O command is an alternative to the Release from Power-Down / Device ID command that provides both the JEDEC assigned Manufacturer ID and the specific Device ID by quad I/O.

The command is initiated by driving the CS# pin low and shifting the command code “94H” followed by a 24-bit address (A23-A0) of 000000H. After which, the Manufacturer ID and the Device ID are shifted out on the falling edge of SCLK with most significant bit (MSB) first as shown in Figure28. If the 24-bit address is initially set to 000001H, the Device ID will be read first.

**Figure28. Read Manufacture ID/ Device ID Quad I/O Sequence Diagram**

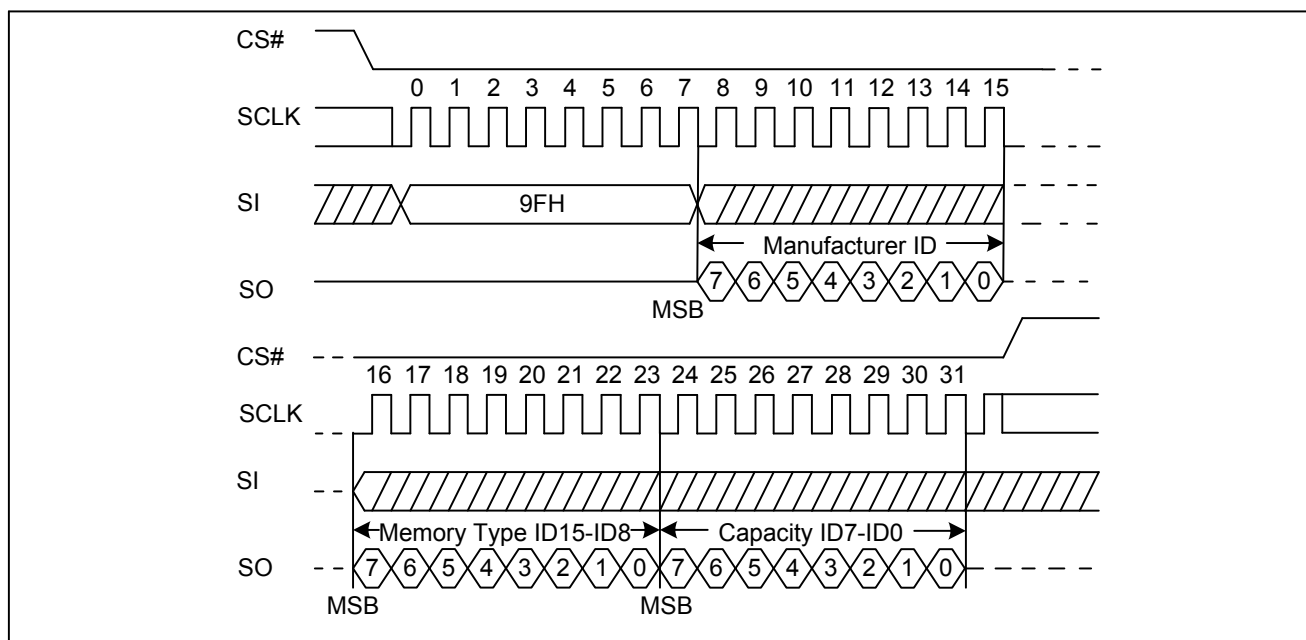


**7.27. Read Identification (RDID) (9FH)**

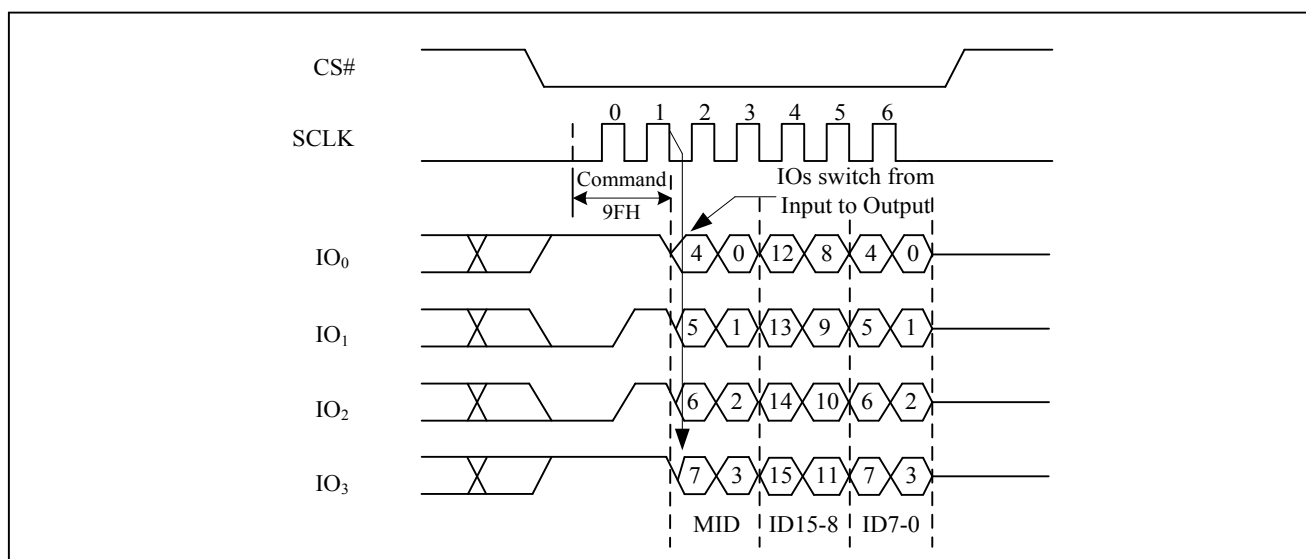
The Read Identification (RDID) command allows the 8-bit manufacturer identification to be read, followed by two bytes of device identification. The device identification indicates the memory type in the first byte, and the memory capacity of the device in the second byte. The Read Identification (RDID) command while an Erase or Program cycle is in progress, is not decoded, and has no effect on the cycle that is in progress. The Read Identification (RDID) command should not be issued while the device is in Deep Power-Down Mode.

The device is first selected by driving CS# low. Then, the 8-bit command code for the command is shifted in. This is followed by the 24-bit device identification, stored in the memory. Each bit is shifted out on the falling edge of Serial Clock. The command sequence is shown in Figure29. The Read Identification (RDID) command is terminated by driving CS# high at any time during data output. When CS# is driven high, the device is in the Standby Mode. Once in the Standby Mode, the device waits to be selected, so that it can receive, decode and execute commands.

**Figure29. Read Identification ID Sequence Diagram**



**Figure29a. Read Identification ID Sequence Diagram (QPI)**

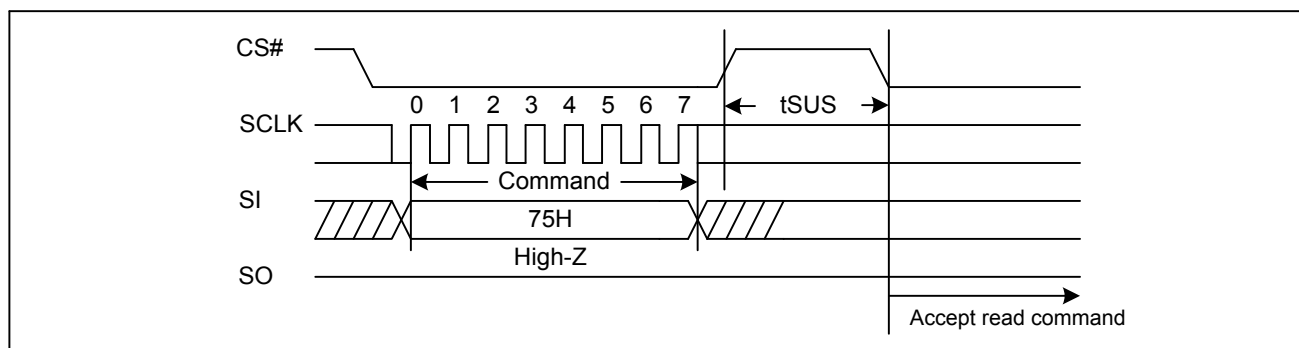


**7.28. Program/Erase Suspend (PES) (75H)**

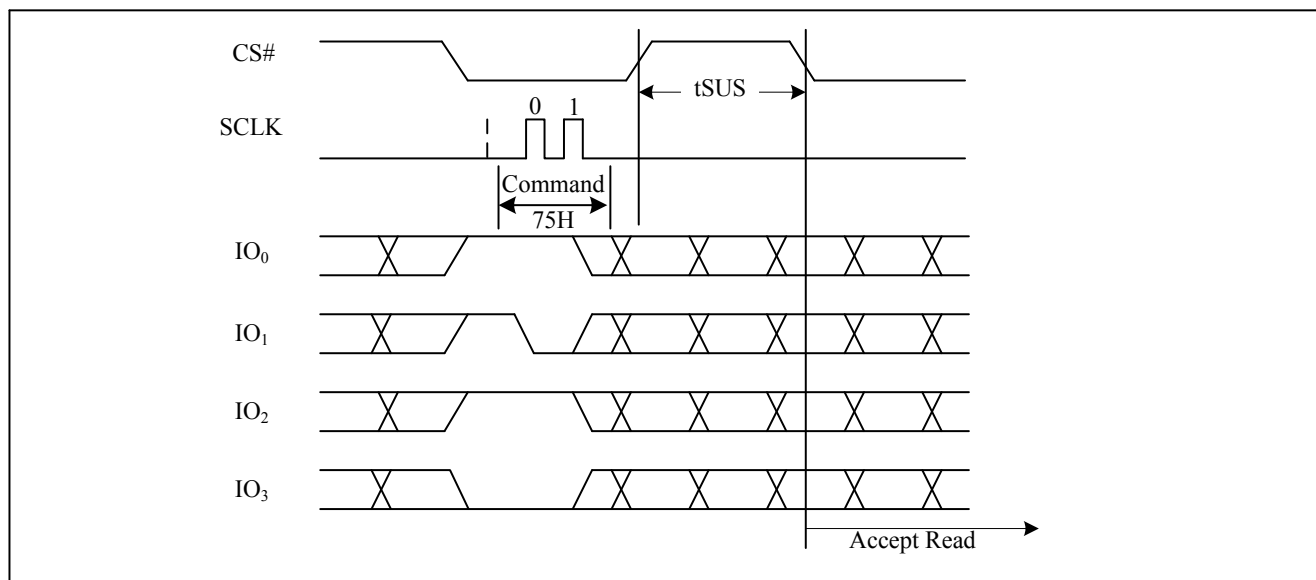
The Program/Erase Suspend command “75H”, allows the system to interrupt a page program or sector/block erase operation and then read data from any other sector or block. The Write Status Register command (01H/31H/11H) and Erase/Program Security Registers command (44H,42H) and Erase commands (20H, 52H, D8H, C7H, 60H) and Page Program command (02H / 32H) are not allowed during Program suspend. The Write Status Register command (01H/31H/11H) and Erase Security Registers command (44H) and Erase commands (20H, 52H, D8H, C7H, 60H) are not allowed during Erase suspend. Program/Erase Suspend is valid only during the page program or sector/block erase operation. A maximum of time of “tsus” (See AC Characteristics) is required to suspend the program/erase operation.

The Program/Erase Suspend command will be accepted by the device only if the SUS2/SUS1 bit in the Status Register equal to 0 and WIP bit equal to 1 while a Page Program or a Sector or Block Erase operation is on-going. If the SUS2/SUS1 bit equal to 1 or WIP bit equal to 0, the Suspend command will be ignored by the device. The WIP bit will be cleared from 1 to 0 within “tsus” and the SUS2/SUS1 bit will be set from 0 to 1 immediately after Program/Erase Suspend. A power-off during the suspend period will reset the device and release the suspend state. The command sequence is show in Figure30.

**Figure30. Program/Erase Suspend Sequence Diagram**



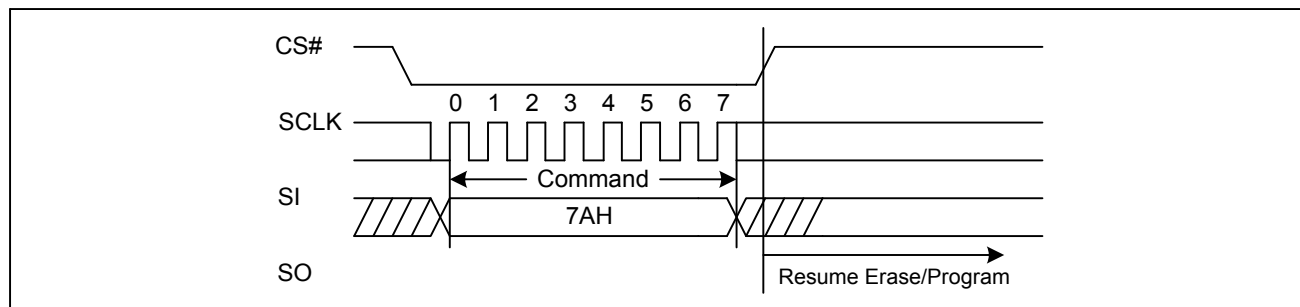
**Figure30a. Program/Erase Suspend Sequence Diagram (QPI)**



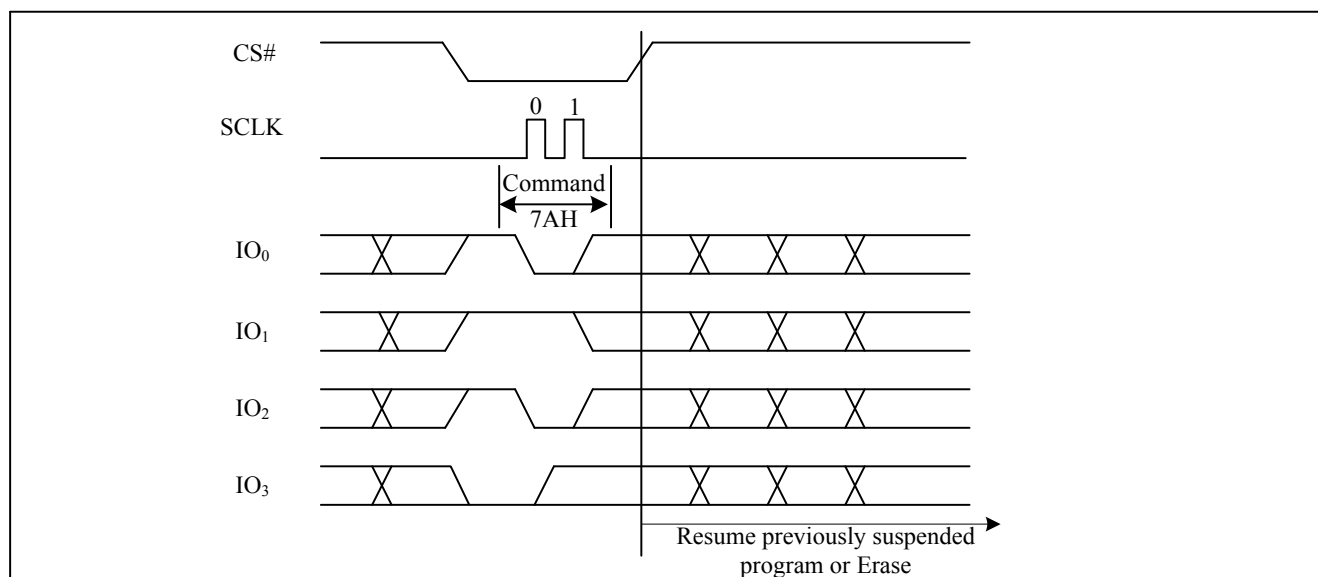
**7.29. Program/Erase Resume (PER) (7AH)**

The Program/Erase Resume command must be written to resume the program or sector/block erase operation after a Program/Erase Suspend command. The Program/Erase Resume command will be accepted by the device only if the SUS2/SUS1 bit equal to 1 and the WIP bit equal to 0. After issued the SUS2/SUS1 bit in the status register will be cleared from 1 to 0 immediately, the WIP bit will be set from 0 to 1 within 200ns and the Sector or Block will complete the erase operation or the page will complete the program operation. The Program/Erase Resume command will be ignored unless a Program/Erase Suspend is active. The command sequence is show in Figure31.

**Figure31. Program/Erase Resume Sequence Diagram**



**Figure31a. Program/Erase Resume Sequence Diagram (QPI)**

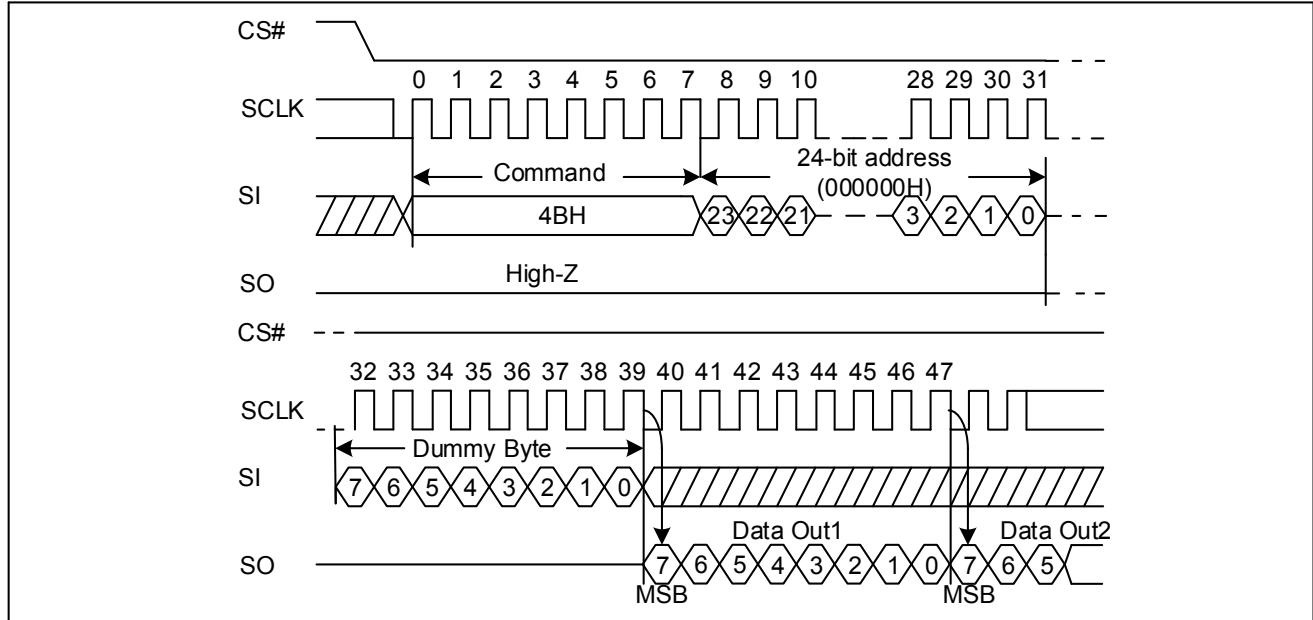


**7.30. Read Unique ID (4BH)**

The Read Unique ID command accesses a factory-set read-only 128bit number that is unique to each device. The Unique ID can be used in conjunction with user software methods to help prevent copying or cloning of a system.

The Read Unique ID command sequence: CS# goes low → sending Read Unique ID command → 3-Byte Address (000000H) → Dummy Byte → 128bit Unique ID Out → CS# goes high.

**Figure32. Read Unique ID Sequence Diagram**



### 7.31. Erase Security Registers (44H)

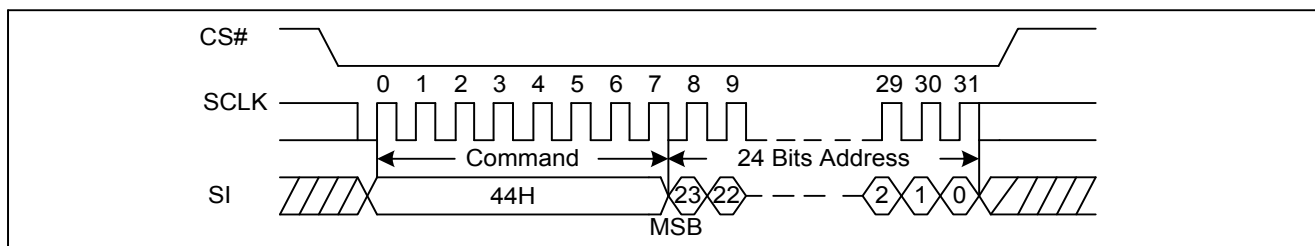
The GD25LE256D provides two 1024-byte Security Registers which can be erased and programmed individually. These registers may be used by the system manufacturers to store security and other important information separately from the main memory array.

The Erase Security Registers command is similar to Sector/Block Erase command. A Write Enable (WREN) command must previously have been executed to set the Write Enable Latch (WEL) bit.

The Erase Security Registers command sequence: CS# goes low → sending Erase Security Registers command → CS# goes high. The command sequence is shown in Figure33. CS# must be driven high after the eighth bit of the last address byte has been latched in; otherwise the Erase Security Registers command is not executed. As soon as CS# is driven high, the self-timed Erase Security Registers cycle (whose duration is  $t_{SE}$ ) is initiated. While the Erase Security Registers cycle is in progress, the Status Register may be read to check the value of the Write in Progress (WIP) bit. The Write in Progress (WIP) bit is 1 during the self-timed Erase Security Registers cycle, and is 0 when it is completed. At some unspecified time before the cycle is completed, the Write Enable Latch (WEL) bit is reset. The Security Registers Lock Bit (LB2-3) in the Status Register can be used to OTP protect the security registers. Once the LB bit is set to 1, the Security Registers will be permanently locked; the Erase Security Registers command will be ignored.

Address	A23-16	A15-12	A11-10	A9-0
Security Register #2	00H	0 0 1 0	0 0	Don't care
Security Register #3	00H	0 0 1 1	0 0	Don't care

**Figure33. Erase Security Registers command Sequence Diagram**



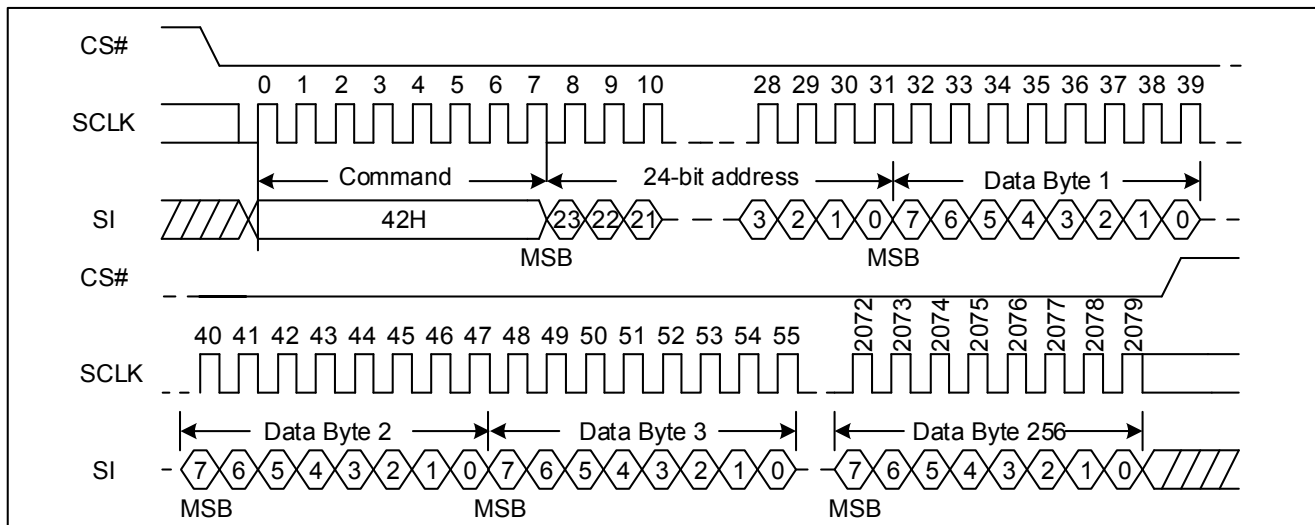
**7.32. Program Security Registers (42H)**

The Program Security Registers command is similar to the Page Program command. Each security register contains four pages content. A Write Enable (WREN) command must previously have been executed to set the Write Enable Latch (WEL) bit before sending the Program Security Registers command. The Program Security Registers command is entered by driving CS# Low, followed by the command code (42H), three address bytes and at least one data byte on SI. As soon as CS# is driven high, the self-timed Program Security Registers cycle (whose duration is  $t_{PP}$ ) is initiated. While the Program Security Registers cycle is in progress, the Status Register may be read to check the value of the Write in Progress (WIP) bit. The Write in Progress (WIP) bit is 1 during the self-timed Program Security Registers cycle, and is 0 when it is completed. At some unspecified time before the cycle is completed, the Write Enable Latch (WEL) bit is reset.

If the Security Registers Lock Bit (LB2-3) is set to 1, the Security Registers will be permanently locked. Program Security Registers command will be ignored.

Address	A23-16	A15-12	A11-10	A9-0
Security Register #2	00H	0 0 1 0	0 0	Byte Address
Security Register #3	00H	0 0 1 1	0 0	Byte Address

**Figure34. Program Security Registers command Sequence Diagram**

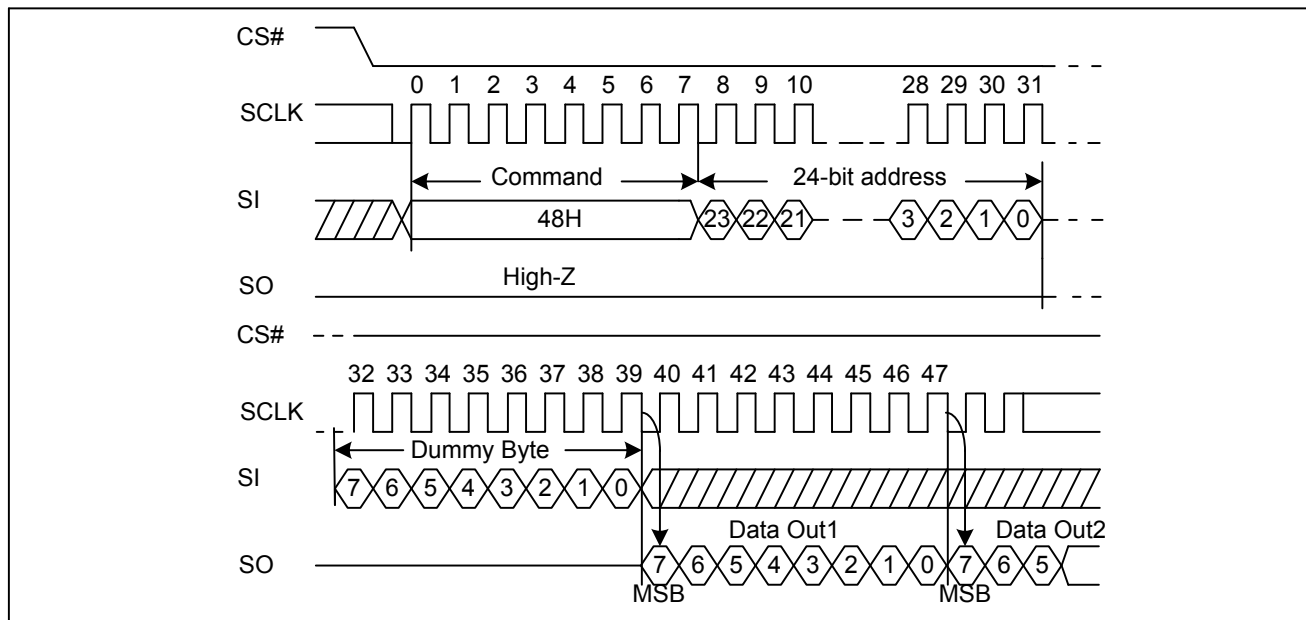


**7.33. Read Security Registers (48H)**

The Read Security Registers command is similar to Fast Read command. The command is followed by a 3-byte address (A23-A0) and a dummy byte, and each bit is latched-in on the rising edge of SCLK. Then the memory content, at that address, is shifted out on SO, and each bit is shifted out, at a Max frequency  $f_c$ , on the falling edge of SCLK. The first byte addressed can be at any location. The address is automatically incremented to the next higher address after each byte of data is shifted out. Once the A9-A0 address reaches the last byte of the register (Byte 3FFH), it will reset to 000H, the command is completed by driving CS# high.

Address	A23-16	A15-12	A11-10	A9-0
Security Register #2	00H	0 0 1 0	0 0	Byte Address
Security Register #3	00H	0 0 1 1	0 0	Byte Address

**Figure35. Read Security Registers command Sequence Diagram**



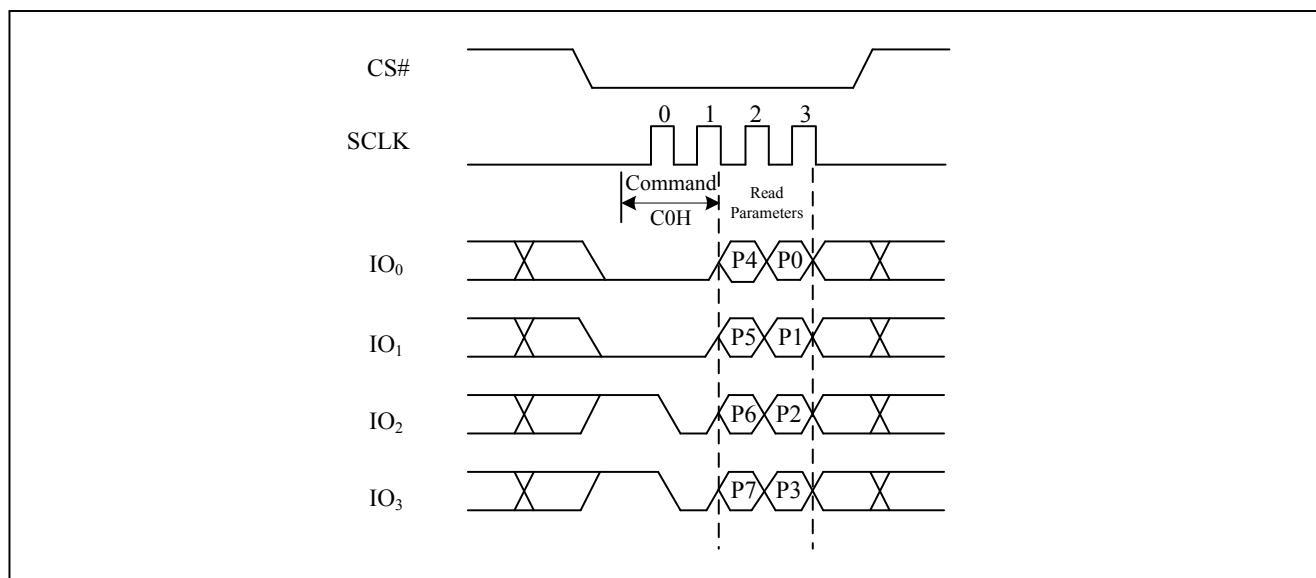


**7.34. Set Read Parameters (C0H)**

In QPI mode the “Set Read Parameters (C0H)” command can be used to configure the number of dummy clocks for “Fast Read (0BH)”, “Quad I/O Fast Read (EBH)”, “Burst Read with Wrap (0CH)”, “Burst Read with Wrap for Lower 128Mb (8CH)” and “Burst Read with Wrap For Higher 128Mb (8DH)” command, and to configure the number of bytes of “Wrap Length” for the “Burst Read with Wrap (0CH)” command. The “Wrap Length” is set by W5-6 bit in the “Set Burst with Wrap (77H)” command. This setting will remain unchanged when the device is switched from Standard SPI mode to QPI mode.

P5-P4	Dummy Clocks	Maximum Read Freq.			P1-P0	Wrap Length
		-40~85°C	-40~105°C	-40~125°C		
0 0	4	80MHz	60MHz	60MHz	0 0	8-byte
0 1	6	108MHz	80MHz	80MHz	0 1	16-byte
1 0	8	120MHz	104MHz	104MHz	1 0	32-byte
1 1	8	120MHz	104MHz	104MHz	1 1	64-byte

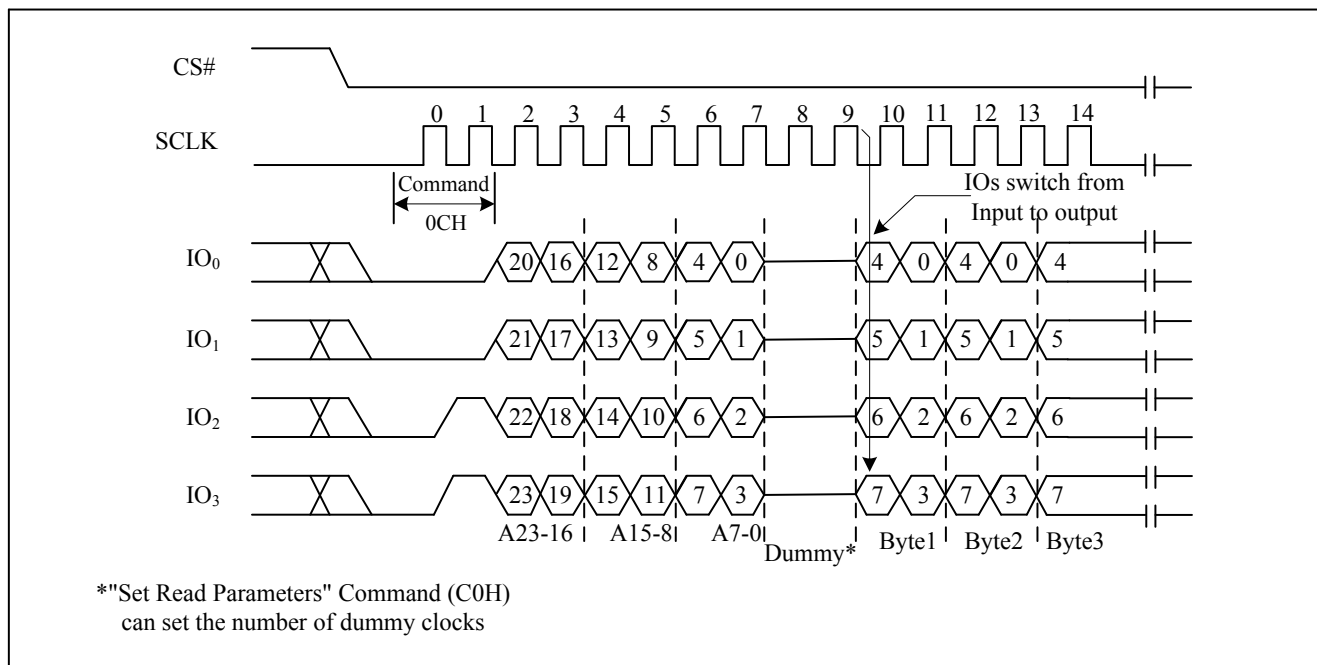
**Figure36. Set Read Parameters command Sequence Diagram**



**7.35. Burst Read with Wrap (0CH)**

The "Burst Read with Wrap (0CH)" command provides an alternative way to perform the read operation with "Wrap Around" in QPI mode. This command is similar to the "Fast Read (0BH)" command in QPI mode, except the addressing of the read operation will "Wrap Around" to the beginning boundary of the "Wrap Around" once the ending boundary is reached. The "Wrap Length" and the number of dummy clocks can be configured by the "Set Read Parameters (C0H)" command.

**Figure37. Burst Read with Wrap command Sequence Diagram**



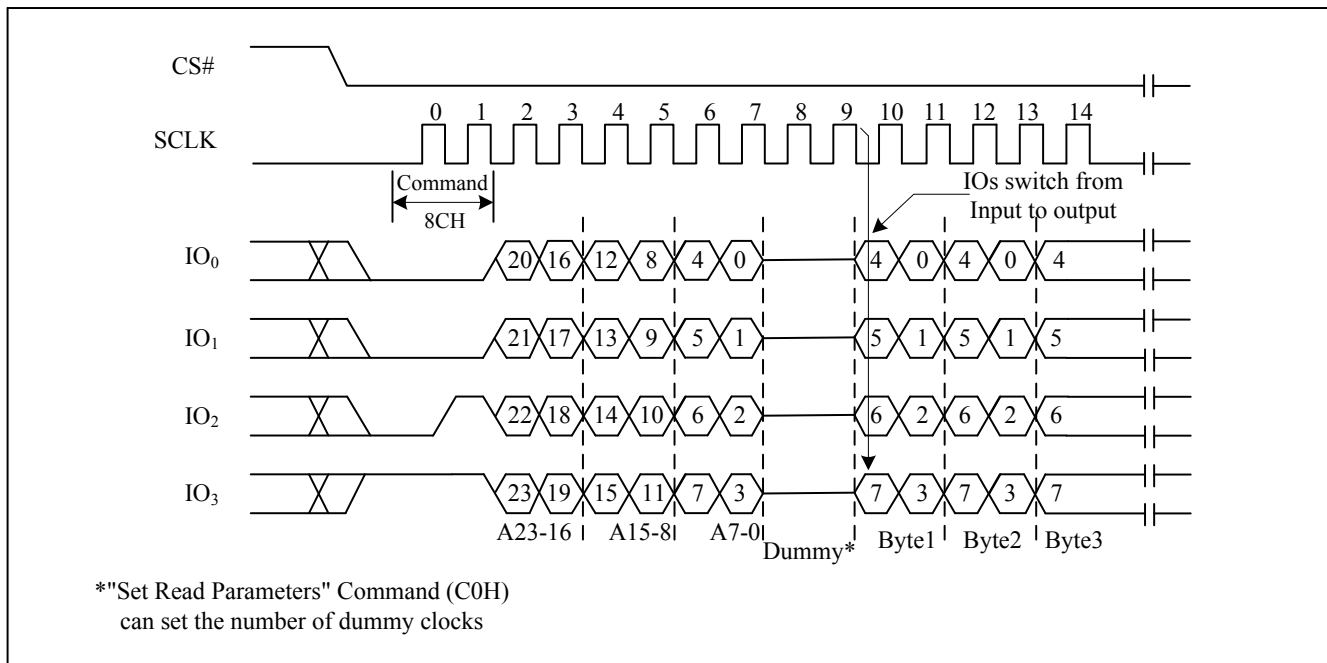
Note: The device default is in 24-bit address mode. For 4-byte mode, the address length becomes 32-bit.

**7.36. Burst Read with Wrap for Lower 128Mb (8CH)**

The "Burst Read with Wrap for Lower 128Mb (8CH)" command provides an alternative way to perform the read operation with "Wrap Around" in QPI mode. This command is similar to the "Fast Read (0BH)" command in QPI mode, except the addressing of the read operation will "Wrap Around" to the beginning boundary of the "Wrap Around" once the ending boundary is reached. The "Wrap Length" and the number of dummy clocks can be configured by the "Set Read Parameters (C0H)" command. The "Burst Read with Wrap for Lower 128Mb (8CH)" command will read out the memory content from 000000H to 0FFFFFFH.

The "Burst Read with Wrap for Lower 128Mb (8CH)" command sequence: CS# goes low → sending The "Burst Read with Wrap for Lower 128Mb (8CH)" command → sending 3-byte address (A23-A0, The A24 default value is 0) → sending dummy byte → then data out.

**Figure38. Burst Read with Wrap for Lower 128Mb command Sequence Diagram**

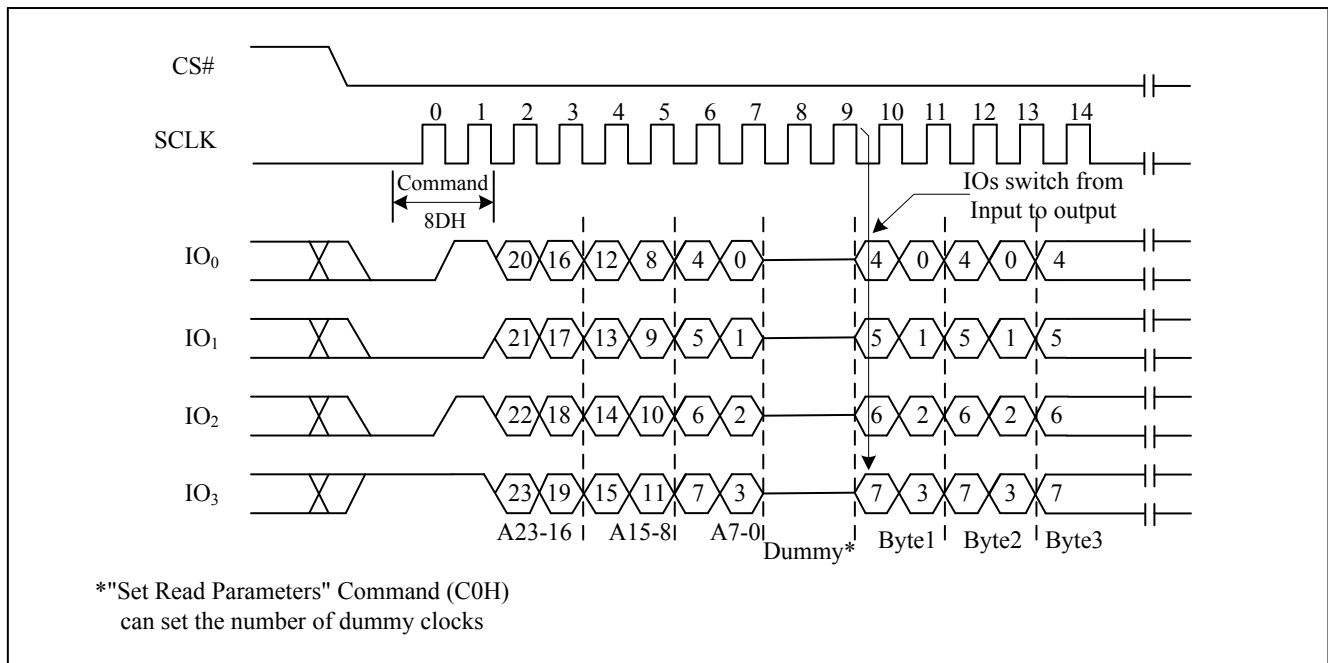


**7.37. Burst Read with Wrap for Higher 128Mb (8DH)**

The “Burst Read with Wrap for Higher 128Mb (8DH)” command provides an alternative way to perform the read operation with “Wrap Around” in QPI mode. This command is similar to the “Fast Read (0BH)” command in QPI mode, except the addressing of the read operation will “Wrap Around” to the beginning boundary of the “Wrap Around” once the ending boundary is reached. The “Wrap Length” and the number of dummy clocks can be configured by the “Set Read Parameters (C0H)” command. The “Burst Read with Wrap for higher 128Mb (8DH)” command will read out the memory content from 1000000H to 1FFFFFFH.

The “Burst Read with Wrap for Higher 128Mb (8DH)” command sequence: CS# goes low → sending The “Burst Read with Wrap for Higher 128Mb (8DH)” command → sending 3-byte address (A23-A0, The A24 default value is 1) → sending dummy byte → then data out.

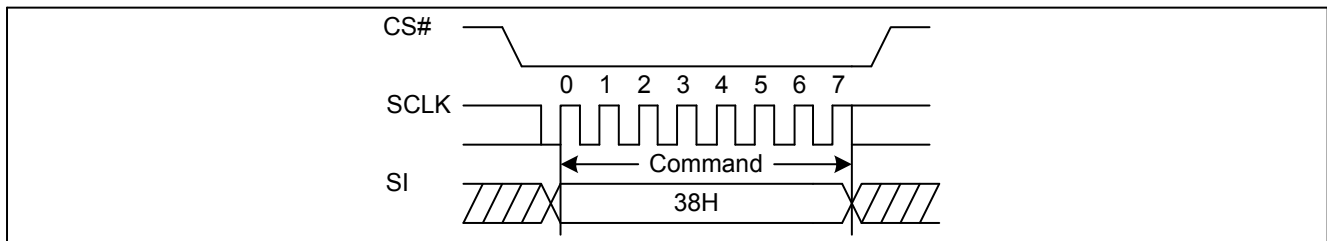
**Figure39. Burst Read with Wrap for Higher 128Mb command Sequence Diagram**



### 7.38. Enable QPI (38H)

The device support both Standard/Dual/Quad SPI and QPI mode. The “Enable QPI (38H)” command can switch the device from SPI mode to QPI mode. See the command Table 2a for all support QPI commands. In order to switch the device to QPI mode, the Quad Enable (QE) bit in Status Register-1 must be set to 1 first, and “Enable QPI (38H)” command must be issued. If the QE bit is 0, the “Enable QPI (38H)” command will be ignored and the device will remain in SPI mode. When the device is switched from SPI mode to QPI mode, the existing Write Enable Latch and Program/Erase Suspend status, and the Wrap Length setting will remain unchanged.

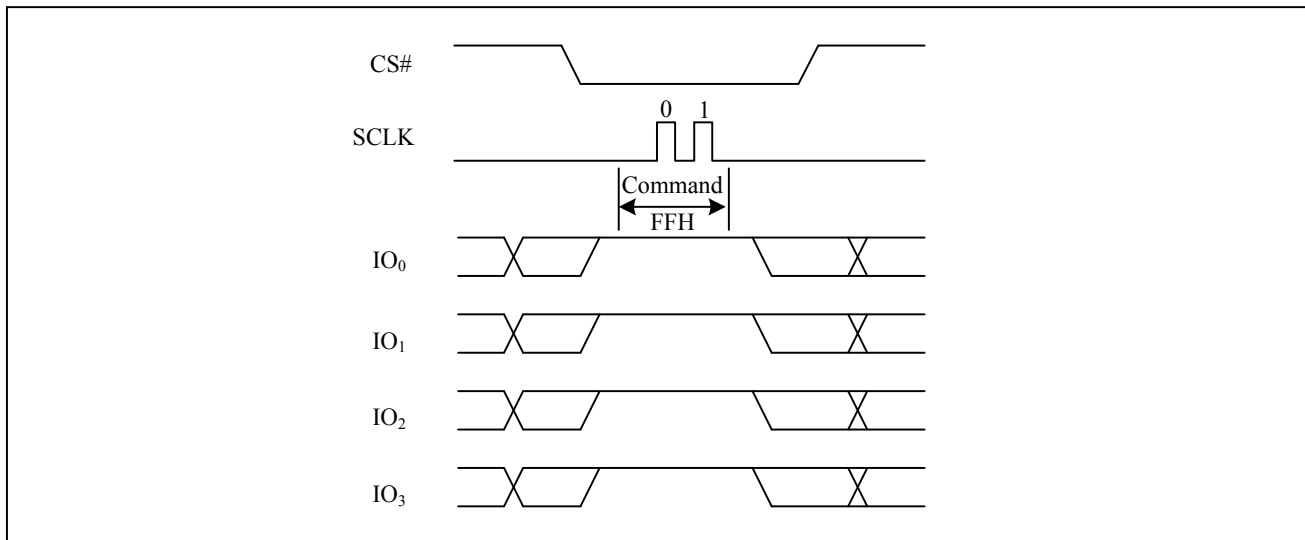
**Figure40. Enable QPI mode command Sequence Diagram**



### 7.39. Disable QPI (FFH)

To exit the QPI mode and return to Standard/Dual/Quad SPI mode, the “Disable QPI (FFH)” command must be issued. When the device is switched from QPI mode to SPI mode, the existing Write Enable Latch and Program/Erase Suspend status, and the Wrap Length setting will remain unchanged.

**Figure41. Disable QPI mode command Sequence Diagram**

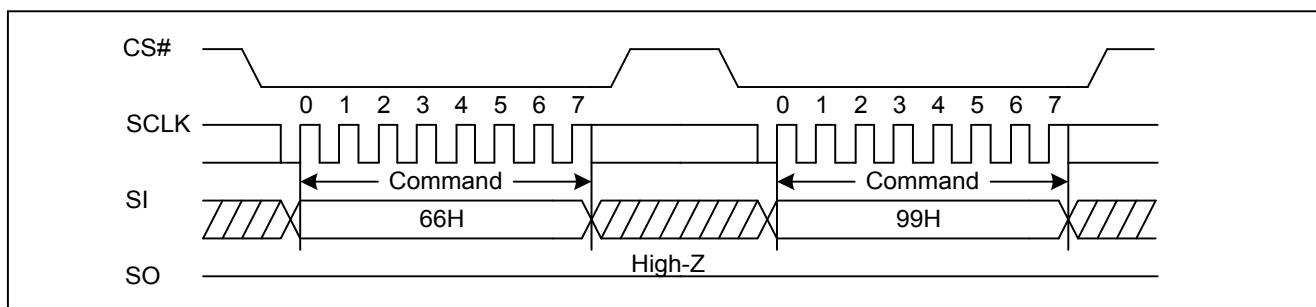


**7.40. Enable Reset (66H) and Reset (99H)**

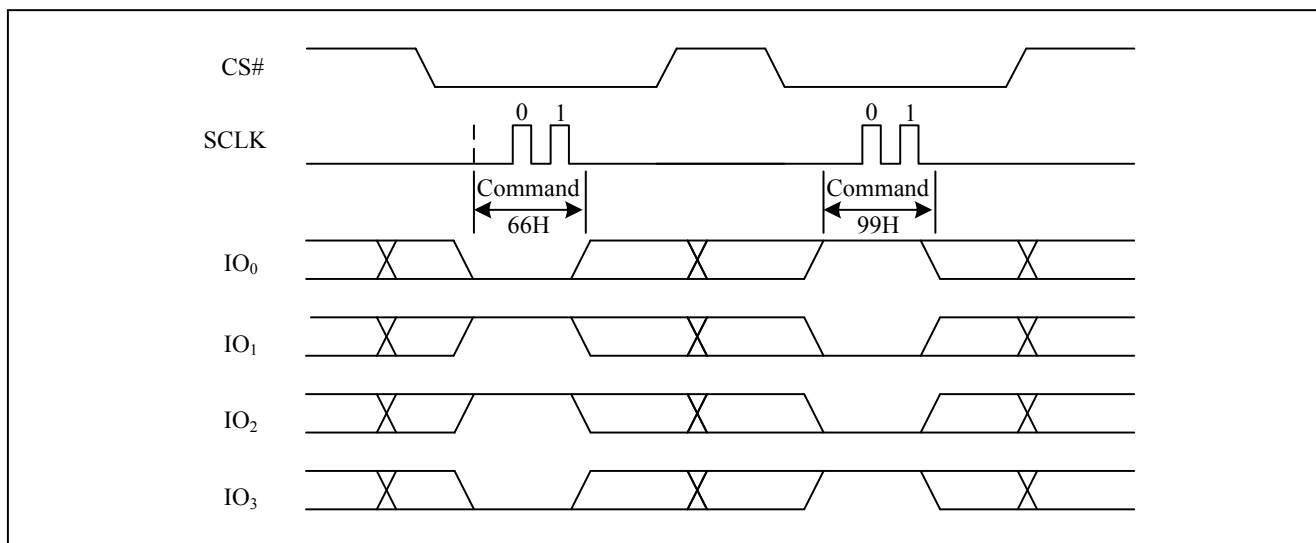
If the Reset command is accepted, any on-going internal operation will be terminated and the device will return to its default power-on state and lose all the current volatile settings, such as Volatile Status Register bits, Write Enable Latch status (WEL), Program/Erase Suspend status, Read Parameter setting (P7-P0), Continuous Read Mode bit setting (M7-M0) and Wrap Bit Setting (W6-W4).

The “Enable Reset (66H)” and the “Reset (99H)” commands can be issued in either SPI or QPI mode. The “Reset (99H)” command sequence as follow: CS# goes low → Sending Enable Reset command → CS# goes high → CS# goes low → Sending Reset command → CS# goes high. Once the Reset command is accepted by the device, the device will take approximately  $t_{RST}$  /  $t_{RST\_E}$  to reset. During this period, no command will be accepted. Data corruption may happen if there is an on-going or suspended internal Erase or Program operation when Reset command sequence is accepted by the device. It is recommended to check the BUSY bit and the SUS bit in Status Register before issuing the Reset command sequence.

**Figure42. Enable Reset and Reset command Sequence Diagram**



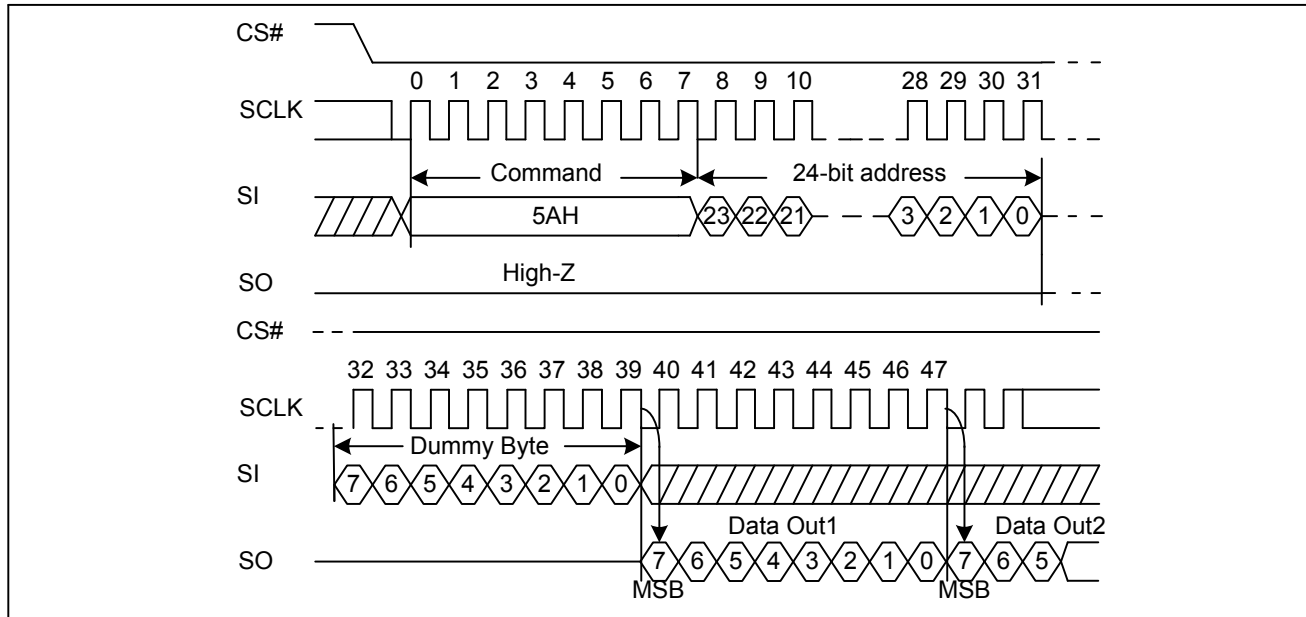
**Figure42a. Enable Reset and Reset command Sequence Diagram (QPI)**



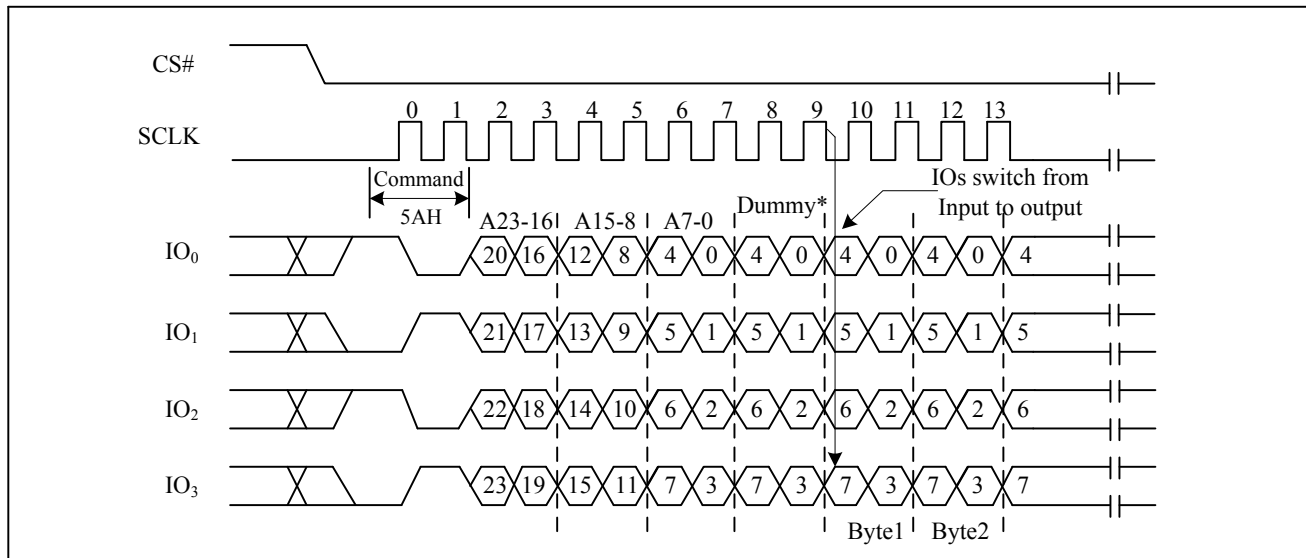
**7.41. Read Serial Flash Discoverable Parameter (5AH)**

The Serial Flash Discoverable Parameter (SFDP) standard provides a consistent method of describing the functional and feature capabilities of serial flash devices in a standard set of internal parameter tables. These parameter tables can be interrogated by host system software to enable adjustments needed to accommodate divergent features from multiple vendors. The concept is similar to the one found in the Introduction of JEDEC Standard, JESD68 on CFI. SFDP is a standard of JEDEC Standard No.216.

**Figure43. Read Serial Flash Discoverable Parameter command Sequence Diagram**



**Figure43a. Read Serial Flash Discoverable Parameter command Sequence Diagram (QPI)**



**Table3. Signature and Parameter Identification Data Values**

Description	Comment	Add(H) (Byte)	DW Add (Bit)	Data	Data
SFDP Signature	Fixed:50444653H	00H	07:00	53H	53H
		01H	15:08	46H	46H
		02H	23:16	44H	44H
		03H	31:24	50H	50H
SFDP Minor Revision Number	Start from 00H	04H	07:00	00H	00H
SFDP Major Revision Number	Start from 01H	05H	15:08	01H	01H
Number of Parameters Headers	Start from 00H	06H	23:16	01H	01H
Unused	Contains 0xFFH and can never be changed	07H	31:24	FFH	FFH
ID number (JEDEC)	00H: It indicates a JEDEC specified header	08H	07:00	00H	00H
Parameter Table Minor Revision Number	Start from 0x00H	09H	15:08	00H	00H
Parameter Table Major Revision Number	Start from 0x01H	0AH	23:16	01H	01H
Parameter Table Length (in double word)	How many DWORDs in the Parameter table	0BH	31:24	09H	09H
Parameter Table Pointer (PTP)	First address of JEDEC Flash Parameter table	0CH	07:00	30H	30H
		0DH	15:08	00H	00H
		0EH	23:16	00H	00H
Unused	Contains 0xFFH and can never be changed	0FH	31:24	FFH	FFH
ID Number LSB (GigaDevice Manufacturer ID)	It is indicates GigaDevice manufacturer ID	10H	07:00	C8H	C8H
Parameter Table Minor Revision Number	Start from 0x00H	11H	15:08	00H	00H
Parameter Table Major Revision Number	Start from 0x01H	12H	23:16	01H	01H
Parameter Table Length (in double word)	How many DWORDs in the Parameter table	13H	31:24	03H	03H
Parameter Table Pointer (PTP)	First address of GigaDevice Flash Parameter table	14H	07:00	60H	60H
		15H	15:08	00H	00H
		16H	23:16	00H	00H
Unused	Contains 0xFFH and can never be changed	17H	31:24	FFH	FFH



**Table4. Parameter Table (0): JEDEC Flash Parameter Tables**

Description	Comment	Add(H) (Byte)	DW Add (Bit)	Data	Data
Block/Sector Erase Size	00: Reserved; 01: 4KB erase; 10: Reserved; 11: not support 4KB erase	30H	01:00	01b	E5H
Write Granularity	0: 1Byte, 1: 64Byte or larger		02	1b	
Write Enable Instruction Requested for Writing to Volatile Status Registers	0: Nonvolatile status bit 1: Volatile status bit (BP status register bit)		03	0b	
Write Enable Opcode Select for Writing to Volatile Status Registers	0: Use 50H Opcode, 1: Use 06H Opcode, Note: If target flash status register is Nonvolatile, then bits 3 and 4 must be set to 00b.		04	0b	
Unused	Contains 111b and can never be changed		07:05	111b	
4KB Erase Opcode		31H	15:08	20H	20H
(1-1-2) Fast Read	0=Not support, 1=Support	32H	16	1b	F3H
Address Bytes Number used in addressing flash array	00: 3Byte only, 01: 3 or 4Byte, 10: 4Byte only, 11: Reserved		18:17	01b	
Double Transfer Rate (DTR) clocking	0=Not support, 1=Support		19	0b	
(1-2-2) Fast Read	0=Not support, 1=Support		20	1b	
(1-4-4) Fast Read	0=Not support, 1=Support		21	1b	
(1-1-4) Fast Read	0=Not support, 1=Support		22	1b	
Unused			23	1b	
Unused		33H	31:24	FFH	FFH
Flash Memory Density		37H:34 H	31:00	0FFFFFFFH	
(1-4-4) Fast Read Number of Wait states	0 0000b: Wait states (Dummy Clocks) not support	38H	04:00	00100b	44H
(1-4-4) Fast Read Number of Mode Bits	000b:Mode Bits not support		07:05	010b	
(1-4-4) Fast Read Opcode		39H	15:08	EBH	EBH
(1-1-4) Fast Read Number of Wait states	0 0000b: Wait states (Dummy Clocks) not support	3AH	20:16	01000b	08H
(1-1-4) Fast Read Number of Mode Bits	000b:Mode Bits not support		23:21	000b	
(1-1-4) Fast Read Opcode		3BH	31:24	6BH	6BH
(1-1-2) Fast Read Number of	0 0000b: Wait states (Dummy	3CH	04:00	01000b	08H

Wait states	Clocks) not support				
(1-1-2) Fast Read Number of Mode Bits	000b: Mode Bits not support		07:05	000b	
(1-1-2) Fast Read Opcode		3DH	15:08	3BH	3BH
(1-2-2) Fast Read Number of Wait states	0 0000b: Wait states (Dummy Clocks) not support	3EH	20:16	00010b	42H
(1-2-2) Fast Read Number of Mode Bits	000b: Mode Bits not support		23:21	010b	
(1-2-2) Fast Read Opcode		3FH	31:24	BBH	BBH
(2-2-2) Fast Read	0=not support 1=support	40H	00	0b	FEH
Unused			03:01	111b	
(4-4-4) Fast Read	0=not support 1=support		04	1b	
Unused			07:05	111b	
Unused		43H:41H	31:08	0xFFH	0xFFH
Unused		45H:44H	15:00	0xFFH	0xFFH
(2-2-2) Fast Read Number of Wait states	0 0000b: Wait states (Dummy Clocks) not support	46H	20:16	00000b	00H
(2-2-2) Fast Read Number of Mode Bits	000b: Mode Bits not support		23:21	000b	
(2-2-2) Fast Read Opcode		47H	31:24	FFH	FFH
Unused		49H:48H	15:00	0xFFH	0xFFH
(4-4-4) Fast Read Number of Wait states	0 0000b: Wait states (Dummy Clocks) not support	4AH	20:16	00100b	44H (1)
(4-4-4) Fast Read Number of Mode Bits	000b: Mode Bits not support		23:21	010b	
(4-4-4) Fast Read Opcode		4BH	31:24	EBH	EBH
Sector Type 1 Size	Sector/block size=2 <sup>N</sup> bytes 0x00b: this sector type don't exist	4CH	07:00	0CH	0CH
Sector Type 1 erase Opcode		4DH	15:08	20H	20H
Sector Type 2 Size	Sector/block size=2 <sup>N</sup> bytes 0x00b: this sector type don't exist	4EH	23:16	0FH	0FH
Sector Type 2 erase Opcode		4FH	31:24	52H	52H
Sector Type 3 Size	Sector/block size=2 <sup>N</sup> bytes 0x00b: this sector type don't exist	50H	07:00	10H	10H
Sector Type 3 erase Opcode		51H	15:08	D8H	D8H
Sector Type 4 Size	Sector/block size=2 <sup>N</sup> bytes 0x00b: this sector type don't exist	52H	23:16	00H	00H
Sector Type 4 erase Opcode		53H	31:24	FFH	FFH

**Table5. Parameter Table (1): GigaDevice Flash Parameter Tables**

Description	Comment	Add(H) (Byte)	DW Add (Bit)	Data	Data
Vcc Supply Maximum Voltage	2000H=2.000V 2700H=2.700V 3600H=3.600V	61H:60 H	15:00	2000H	2000H
Vcc Supply Minimum Voltage	1650H=1.650V 2250H=2.250V 2350H=2.350V 2700H=2.700V	63H:62 H	31:16	1650H	1650H
HW Reset# pin	0=not support 1=support	65H:64 H	00	0b	F99EH
HW Hold# pin	0=not support 1=support		01	1b	
Deep Power Down Mode	0=not support 1=support		02	1b	
SW Reset	0=not support 1=support		03	1b	
SW Reset Opcode	Should be issue Reset Enable(66H) before Reset cmd.		11:04	99H	
Program Suspend/Resume	0=not support 1=support		12	1b	
Erase Suspend/Resume	0=not support 1=support		13	1b	
Unused			14	1b	
Wrap-Around Read mode	0=not support 1=support		15	1b	
Wrap-Around Read mode Opcode		66H	23:16	77H	77H
Wrap-Around Read data length	08H:support 8B wrap-around read 16H:8B&16B 32H:8B&16B&32B 64H:8B&16B&32B&64B	67H	31:24	64H	64H
Individual block lock	0=not support 1=support	6BH:68 H	00	0b	EBFC H
Individual block lock bit (Volatile/Nonvolatile)	0=Volatile 1=Nonvolatile		01	0b	
Individual block lock Opcode			09:02	FFH	
Individual block lock Volatile protect bit default protect status	0=protect 1=unprotect		10	0b	
Secured OTP	0=not support 1=support		11	1b	
Read Lock	0=not support 1=support		12	0b	
Permanent Lock	0=not support 1=support		13	1b	
Unused			15:14	11b	
Unused			31:16	FFFFH	

## 8. ELECTRICAL CHARACTERISTICS

### 8.1. POWER-ON TIMING

Figure44. Power-on Timing

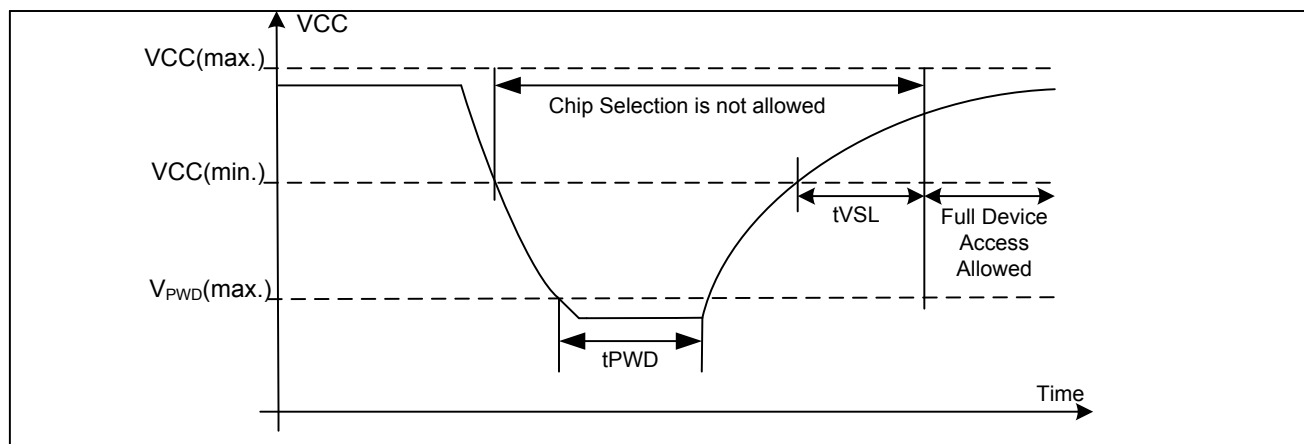


Table6. Power-Up Timing and Write Inhibit Threshold

Symbol	Parameter	Min.	Max.	Unit
tVSL	VCC (min.) to device operation	2.5		ms
VWI	Write Inhibit Voltage	1	1.5	V
VPWD	VCC voltage needed to below VPWD for ensuring initialization will occur		0.5	V
tPWD	The minimum duration for ensuring initialization will occur	300		us

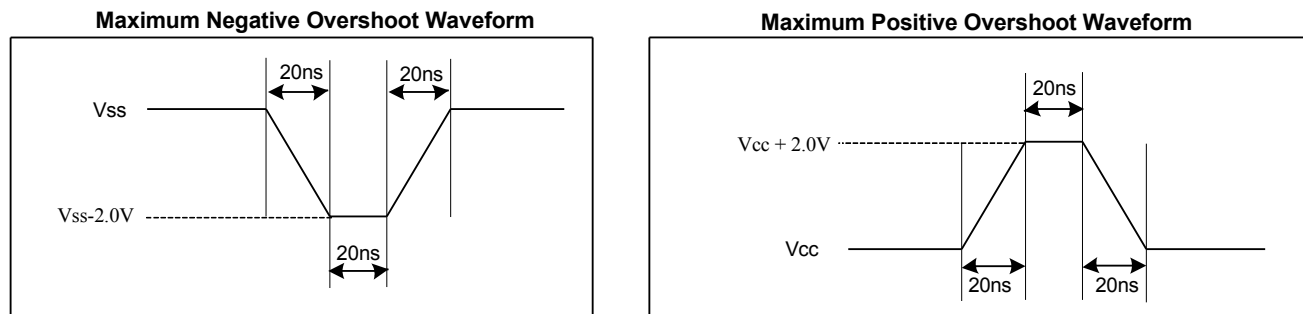
### 8.2. INITIAL DELIVERY STATE

The device is delivered with the memory array erased: all bits are set to 1(each byte contains FFH).The Status Register contains 00H (all Status Register bits are 0).

### 8.3. ABSOLUTE MAXIMUM RATINGS

Parameter	Value	Unit
Ambient Operating Temperature	-40 to 85 -40 to 105 -40 to 125	°C
Storage Temperature	-65 to 150	°C
Transient Input/Output Voltage (note: overshoot)	-2.0 to VCC+2.0	V
Applied Input/Output Voltage	-0.6 to VCC+0.4	V
VCC	-0.6 to 2.5	V

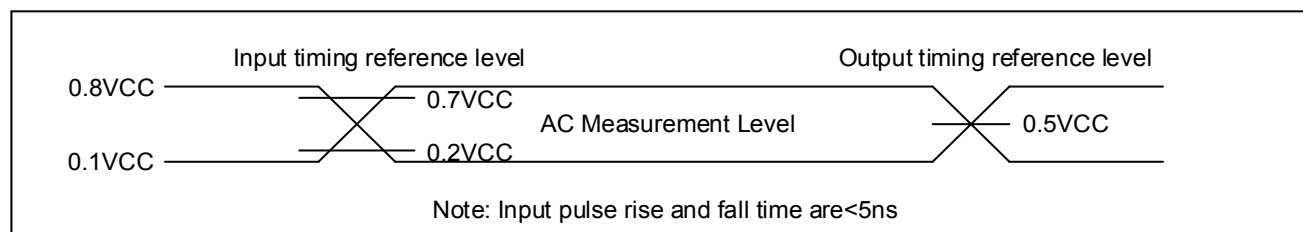
**Figure45. Input Test Waveform and Measurement Level**



**8.4. CAPACITANCE MEASUREMENT CONDITIONS**

Symbol	Parameter	Min	Typ.	Max	Unit	Conditions
CIN	Input Capacitance			12	pF	VIN=0V
COUT	Output Capacitance			16	pF	VOUT=0V
CL	Load Capacitance	30			pF	
	Input Rise And Fall time			5	ns	
	Input Pause Voltage	0.1VCC to 0.8VCC			V	
	Input Timing Reference Voltage	0.2VCC to 0.7VCC			V	
	Output Timing Reference Voltage	0.5VCC			V	

**Figure46. Input Test Waveform and Measurement Level**



**8.5. DC CHARACTERISTICS**

(T= -40°C~85°C, VCC=1.65~2.0V)

Symbol	Parameter	Test Condition	Min.	Typ.	Max.	Unit.
I <sub>LI</sub>	Input Leakage Current				±4	μA
I <sub>LO</sub>	Output Leakage Current				±4	μA
I <sub>CC1</sub>	Standby Current	CS#=VCC, V <sub>IN</sub> =VCC or VSS		70	100	μA
I <sub>CC2</sub>	Deep Power-Down Current	CS#=VCC, V <sub>IN</sub> =VCC or VSS		0.4	16	μA
I <sub>CC3</sub>	Operating Current (Read)	CLK=0.1VCC / 0.9VCC at 120MHz, Q=Open(*1,*2,*4 I/O)		12	20	mA
		CLK=0.1VCC / 0.9VCC at 80MHz, Q=Open(*1,*2,*4 I/O)		10	18	mA
I <sub>CC4</sub>	Operating Current (PP)	CS#=VCC			20	mA
I <sub>CC5</sub>	Operating Current (WRSR)	CS#=VCC			20	mA
I <sub>CC6</sub>	Operating Current (SE)	CS#=VCC			20	mA
I <sub>CC7</sub>	Operating Current (BE)	CS#=VCC			20	mA
I <sub>CC8</sub>	Operating Current (CE)	CS#=VCC			20	mA
V <sub>IL</sub>	Input Low Voltage		-0.5		0.2VCC	V
V <sub>IH</sub>	Input High Voltage		0.7VCC		VCC+0.4	V
V <sub>OL</sub>	Output Low Voltage	I <sub>OL</sub> =100μA			0.2	V
V <sub>OH</sub>	Output High Voltage	I <sub>OH</sub> =-100μA	VCC-0.2			V

Note:

1. Typical values given for TA=25°C.
2. Value guaranteed by design and/or characterization, not 100% tested in production.

(T= -40°C~105°C, VCC=1.65~2.0V)

Symbol	Parameter	Test Condition	Min.	Typ.	Max.	Unit.
I <sub>LI</sub>	Input Leakage Current				±4	μA
I <sub>LO</sub>	Output Leakage Current				±4	μA
I <sub>CC1</sub>	Standby Current	CS#=VCC, V <sub>IN</sub> =VCC or VSS		70	200	μA
I <sub>CC2</sub>	Deep Power-Down Current	CS#=VCC, V <sub>IN</sub> =VCC or VSS		0.4	60	μA
I <sub>CC3</sub>	Operating Current (Read)	CLK=0.1VCC / 0.9VCC at 104MHz, Q=Open(*1,*2,*4 I/O)		12	20	mA
		CLK=0.1VCC / 0.9VCC at 80MHz, Q=Open(*1,*2,*4 I/O)		10	18	mA
I <sub>CC4</sub>	Operating Current (PP)	CS#=VCC			25	mA
I <sub>CC5</sub>	Operating Current (WRSR)	CS#=VCC			25	mA
I <sub>CC6</sub>	Operating Current (SE)	CS#=VCC			25	mA
I <sub>CC7</sub>	Operating Current (BE)	CS#=VCC			25	mA
I <sub>CC8</sub>	Operating Current (CE)	CS#=VCC			25	mA
V <sub>IL</sub>	Input Low Voltage		-0.5		0.2VCC	V
V <sub>IH</sub>	Input High Voltage		0.7VCC		VCC+0.4	V
V <sub>OL</sub>	Output Low Voltage	I <sub>OL</sub> =100μA			0.2	V
V <sub>OH</sub>	Output High Voltage	I <sub>OH</sub> =-100μA	VCC-0.2			V

Note:

1. Typical values given for TA=25°C.
2. Value guaranteed by design and/or characterization, not 100% tested in production.

(T= -40°C~125°C, VCC=1.65~2.0V)

Symbol	Parameter	Test Condition	Min.	Typ.	Max.	Unit.
I <sub>LI</sub>	Input Leakage Current				±4	μA
I <sub>LO</sub>	Output Leakage Current				±4	μA
I <sub>CC1</sub>	Standby Current	CS#=VCC, V <sub>IN</sub> =VCC or VSS		70	240	μA
I <sub>CC2</sub>	Deep Power-Down Current	CS#=VCC, V <sub>IN</sub> =VCC or VSS		0.4	80	μA
I <sub>CC3</sub>	Operating Current (Read)	CLK=0.1VCC / 0.9VCC at 104MHz, Q=Open(*1,*2,*4 I/O)		12	20	mA
		CLK=0.1VCC / 0.9VCC at 80MHz, Q=Open(*1,*2,*4 I/O)		10	18	mA
I <sub>CC4</sub>	Operating Current (PP)	CS#=VCC			25	mA
I <sub>CC5</sub>	Operating Current (WRSR)	CS#=VCC			25	mA
I <sub>CC6</sub>	Operating Current (SE)	CS#=VCC			25	mA
I <sub>CC7</sub>	Operating Current (BE)	CS#=VCC			25	mA
I <sub>CC8</sub>	Operating Current (CE)	CS#=VCC			25	mA
V <sub>IL</sub>	Input Low Voltage		-0.5		0.2VCC	V
V <sub>IH</sub>	Input High Voltage		0.7VCC		VCC+0.4	V
V <sub>OL</sub>	Output Low Voltage	I <sub>OL</sub> =100μA			0.2	V
V <sub>OH</sub>	Output High Voltage	I <sub>OH</sub> =-100μA	VCC-0.2			V

Note:

1. Typical values given for TA=25°C.
2. Value guaranteed by design and/or characterization, not 100% tested in production.



**8.6. AC CHARACTERISTICS**

(T= -40°C~85°C, VCC=1.65~2.0V, C<sub>L</sub>=30pf)

Symbol	Parameter	Min.	Typ.	Max.	Unit.
f <sub>c</sub>	Serial Clock Frequency For: all command except for 03H			120	MHz
f <sub>r</sub>	Serial Clock Frequency For: Read (03H)			80	MHz
t <sub>CLH</sub>	Serial Clock High Time	3.5			ns
t <sub>CLL</sub>	Serial Clock Low Time	3.5			ns
t <sub>CLCH</sub>	Serial Clock Rise Time (Slew Rate)	0.1			V/ns
t <sub>CHCL</sub>	Serial Clock Fall Time (Slew Rate)	0.1			V/ns
t <sub>SLCH</sub>	CS# Active Setup Time	5			ns
t <sub>CHSH</sub>	CS# Active Hold Time	5			ns
t <sub>SHCH</sub>	CS# Not Active Setup Time	5			ns
t <sub>CHSL</sub>	CS# Not Active Hold Time	5			ns
t <sub>SHSL</sub>	CS# High Time (Read/Write)	20			ns
t <sub>SHQZ</sub>	Output Disable Time			6	ns
t <sub>CLQX</sub>	Output Hold Time	1.2			ns
t <sub>DVCH</sub>	Data In Setup Time	2			ns
t <sub>CHDX</sub>	Data In Hold Time	2			ns
t <sub>HLCH</sub>	HOLD# Low Setup Time (Relative To Clock)	5			ns
t <sub>HHCH</sub>	HOLD# High Setup Time (Relative To Clock)	5			ns
t <sub>CHHL</sub>	HOLD# High Hold Time (Relative To Clock)	5			ns
t <sub>CHHH</sub>	HOLD# Low Hold Time (Relative To Clock)	5			ns
t <sub>HLQZ</sub>	HOLD# Low To High-Z Output			6	ns
t <sub>HHQX</sub>	HOLD# High To Low-Z Output			6	ns
t <sub>CLQV</sub>	Clock Low To Output Valid			7	ns
t <sub>WHSL</sub>	Write Protect Setup Time Before CS# Low	20			ns
t <sub>SHWL</sub>	Write Protect Hold Time After CS# High	100			ns
t <sub>RST</sub>	CS# High To Next Command After Reset (Except From Erase)			30	μs
t <sub>RST_E</sub>	CS# High To Next Command After Reset (From Erase)			12	ms
t <sub>DP</sub>	CS# High To Deep Power-Down Mode			20	μs
t <sub>RES1</sub>	CS# High To Standby Mode Without Electronic Signature Read			20	μs
t <sub>RES2</sub>	CS# High To Standby Mode With Electronic Signature Read			20	μs
t <sub>SUS</sub>	CS# High To Next Command After Suspend			20	μs
t <sub>RS</sub>	Latency Between Resume And Next Suspend	100			μs
t <sub>W</sub>	Write Status Register Cycle Time		10	60	ms
t <sub>PP</sub>	Page Programming Time		0.5	2.4	ms
t <sub>SE</sub>	Sector Erase Time		70	400	ms
t <sub>BE</sub>	Block Erase Time (32K Bytes)		0.16	0.8	s
t <sub>BE</sub>	Block Erase Time (64K Bytes)		0.3	1.2	s
t <sub>CE</sub>	Chip Erase Time (GD25LE256D)		100	240	s

Note:

1. Typical values given for TA=25°C.
2. Value guaranteed by design and/or characterization, not 100% tested in production.

(T= -40°C~105°C, VCC=1.65~2.0V, CL=30pf)

Symbol	Parameter	Min.	Typ.	Max.	Unit.
f <sub>C</sub>	Serial Clock Frequency For: all command except for 03H			104	MHz
f <sub>R</sub>	Serial Clock Frequency For: Read (03H)			80	MHz
t <sub>CLH</sub>	Serial Clock High Time	4.0			ns
t <sub>CLL</sub>	Serial Clock Low Time	4.0			ns
t <sub>CLCH</sub>	Serial Clock Rise Time (Slew Rate)	0.2			V/ns
t <sub>CHCL</sub>	Serial Clock Fall Time (Slew Rate)	0.2			V/ns
t <sub>SLCH</sub>	CS# Active Setup Time	5			ns
t <sub>CHSH</sub>	CS# Active Hold Time	5			ns
t <sub>SHCH</sub>	CS# Not Active Setup Time	5			ns
t <sub>CHSL</sub>	CS# Not Active Hold Time	5			ns
t <sub>SHSL</sub>	CS# High Time (Read/Write)	20			ns
t <sub>SHQZ</sub>	Output Disable Time			6	ns
t <sub>CLQX</sub>	Output Hold Time	1.2			ns
t <sub>DVCH</sub>	Data In Setup Time	2			ns
t <sub>CHDX</sub>	Data In Hold Time	2			ns
t <sub>HLCH</sub>	HOLD# Low Setup Time (Relative To Clock)	5			ns
t <sub>HHCH</sub>	HOLD# High Setup Time (Relative To Clock)	5			ns
t <sub>CHHL</sub>	HOLD# High Hold Time (Relative To Clock)	5			ns
t <sub>CHHH</sub>	HOLD# Low Hold Time (Relative To Clock)	5			ns
t <sub>HLQZ</sub>	HOLD# Low To High-Z Output			6	ns
t <sub>HHQX</sub>	HOLD# High To Low-Z Output			6	ns
t <sub>CLQV</sub>	Clock Low To Output Valid			7	ns
t <sub>WHSL</sub>	Write Protect Setup Time Before CS# Low	20			ns
t <sub>SHWL</sub>	Write Protect Hold Time After CS# High	100			ns
t <sub>RST</sub>	CS# High To Next Command After Reset (Except From Erase)			30	μs
t <sub>RST_E</sub>	CS# High To Next Command After Reset (From Erase)			12	ms
t <sub>DP</sub>	CS# High To Deep Power-Down Mode			20	μs
t <sub>RES1</sub>	CS# High To Standby Mode Without Electronic Signature Read			20	μs
t <sub>RES2</sub>	CS# High To Standby Mode With Electronic Signature Read			20	μs
t <sub>SUS</sub>	CS# High To Next Command After Suspend			20	μs
t <sub>RS</sub>	Latency Between Resume And Next Suspend	100			μs
t <sub>W</sub>	Write Status Register Cycle Time		10	60	ms
t <sub>PP</sub>	Page Programming Time		0.5	2.4	ms
t <sub>SE</sub>	Sector Erase Time		70	400	ms
t <sub>BE</sub>	Block Erase Time (32K Bytes)		0.16	1.2	s
t <sub>BE</sub>	Block Erase Time (64K Bytes)		0.3	2.4	s
t <sub>CE</sub>	Chip Erase Time (GD25LE256D)		100	240	s

Note:

1. Typical values given for TA=25°C.
2. Value guaranteed by design and/or characterization, not 100% tested in production.

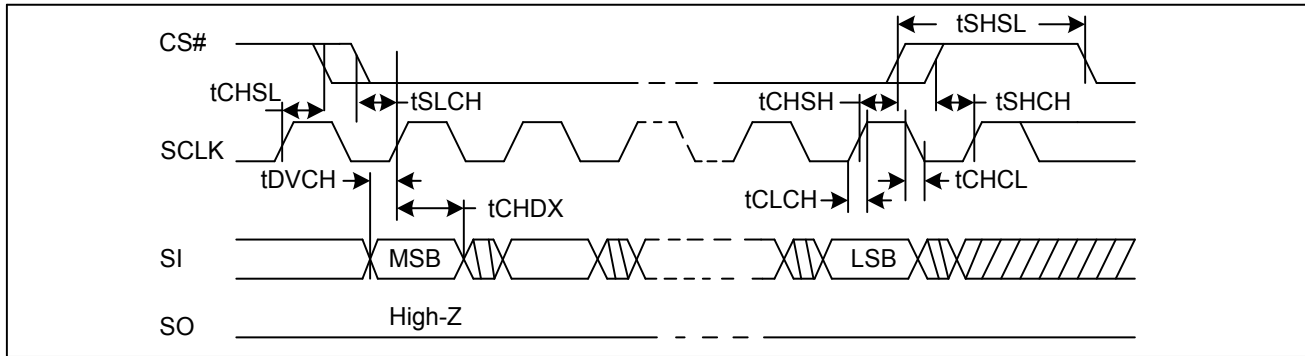
(T= -40°C~125°C, VCC=1.65~2.0V, CL=30pf)

Symbol	Parameter	Min.	Typ.	Max.	Unit.
f <sub>c</sub>	Serial Clock Frequency For: all command except for 03H			104	MHz
f <sub>R</sub>	Serial Clock Frequency For: Read (03H)			80	MHz
t <sub>CLH</sub>	Serial Clock High Time	4.0			ns
t <sub>CLL</sub>	Serial Clock Low Time	4.0			ns
t <sub>CLCH</sub>	Serial Clock Rise Time (Slew Rate)	0.2			V/ns
t <sub>CHCL</sub>	Serial Clock Fall Time (Slew Rate)	0.2			V/ns
t <sub>SLCH</sub>	CS# Active Setup Time	5			ns
t <sub>CHSH</sub>	CS# Active Hold Time	5			ns
t <sub>SHCH</sub>	CS# Not Active Setup Time	5			ns
t <sub>CHSL</sub>	CS# Not Active Hold Time	5			ns
t <sub>SHSL</sub>	CS# High Time (Read/Write)	20			ns
t <sub>SHQZ</sub>	Output Disable Time			6	ns
t <sub>CLQX</sub>	Output Hold Time	1.2			ns
t <sub>DVCH</sub>	Data In Setup Time	2			ns
t <sub>CHDX</sub>	Data In Hold Time	2			ns
t <sub>HLCH</sub>	HOLD# Low Setup Time (Relative To Clock)	5			ns
t <sub>HHCH</sub>	HOLD# High Setup Time (Relative To Clock)	5			ns
t <sub>CHHL</sub>	HOLD# High Hold Time (Relative To Clock)	5			ns
t <sub>CHHH</sub>	HOLD# Low Hold Time (Relative To Clock)	5			ns
t <sub>HLQZ</sub>	HOLD# Low To High-Z Output			6	ns
t <sub>HHQX</sub>	HOLD# High To Low-Z Output			6	ns
t <sub>CLQV</sub>	Clock Low To Output Valid			7	ns
t <sub>WHSL</sub>	Write Protect Setup Time Before CS# Low	20			ns
t <sub>SHWL</sub>	Write Protect Hold Time After CS# High	100			ns
t <sub>RST</sub>	CS# High To Next Command After Reset (Except From Erase)			30	μs
t <sub>RST_E</sub>	CS# High To Next Command After Reset (From Erase)			12	ms
t <sub>DP</sub>	CS# High To Deep Power-Down Mode			20	μs
t <sub>RES1</sub>	CS# High To Standby Mode Without Electronic Signature Read			20	μs
t <sub>RES2</sub>	CS# High To Standby Mode With Electronic Signature Read			20	μs
t <sub>SUS</sub>	CS# High To Next Command After Suspend			20	μs
t <sub>RS</sub>	Latency Between Resume And Next Suspend	100			μs
t <sub>W</sub>	Write Status Register Cycle Time		10	60	ms
t <sub>PP</sub>	Page Programming Time		0.5	4	ms
t <sub>SE</sub>	Sector Erase Time		70	500	ms
t <sub>BE</sub>	Block Erase Time (32K Bytes)		0.16	1.5	s
t <sub>BE</sub>	Block Erase Time (64K Bytes)		0.3	3.0	s
t <sub>CE</sub>	Chip Erase Time (GD25LE256D)		100	300	s

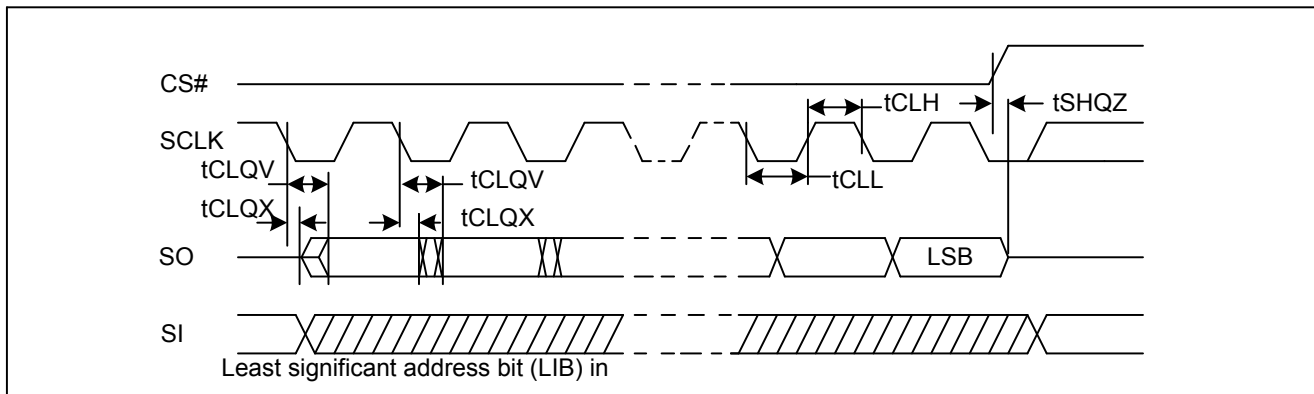
Note:

1. Typical values given for TA=25°C.
2. Value guaranteed by design and/or characterization, not 100% tested in production.

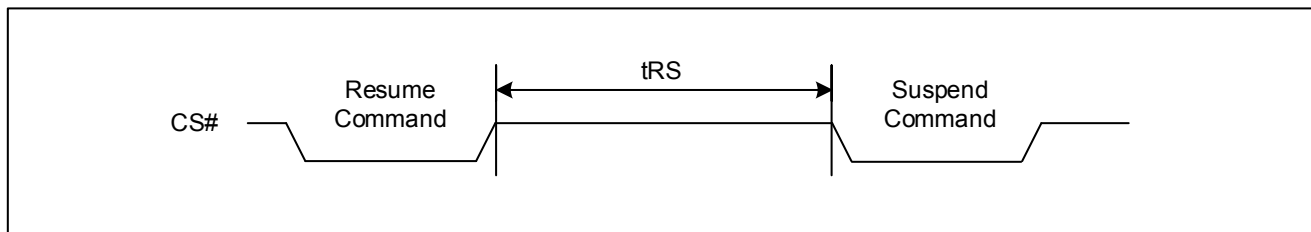
**Figure47. Serial Input Timing**



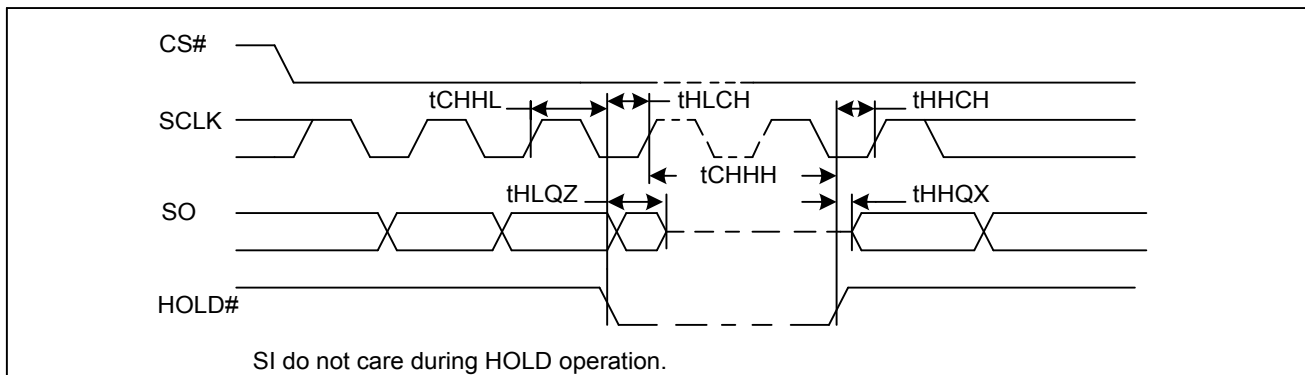
**Figure48. Output Timing**



**Figure49. Resume to Suspend Timing Diagram**

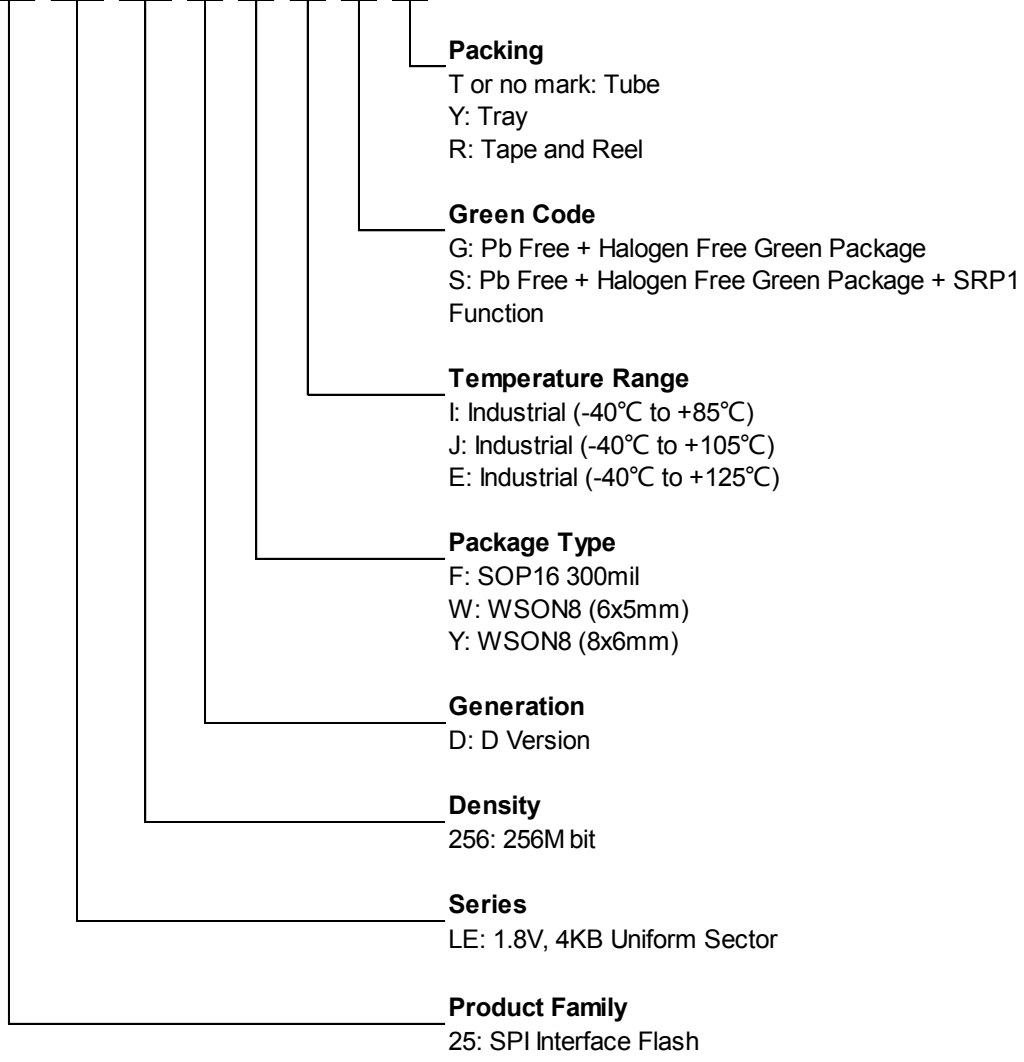


**Figure50. Hold Timing**



**9. ORDERING INFORMATION**

**GD XX XX XX X X X X X**



**9.1. Valid Part Numbers**

Please contact GigaDevice regional sales for the latest product selection and available form factors.

**Temperature Range I: Industrial (-40°C to +85°C)**

Product Number	Density	Package Type
GD25LE256DFIG	256Mbit	SOP16 300mil
GD25LE256DFIS		
GD25LE256DWIG	256Mbit	WSON8 (6x5mm)
GD25LE256DWIS		
GD25LE256DYIG	256Mbit	WSON8 (8x6mm)
GD25LE256DYIS		

**Temperature Range J: Industrial (-40°C to +105°C)**

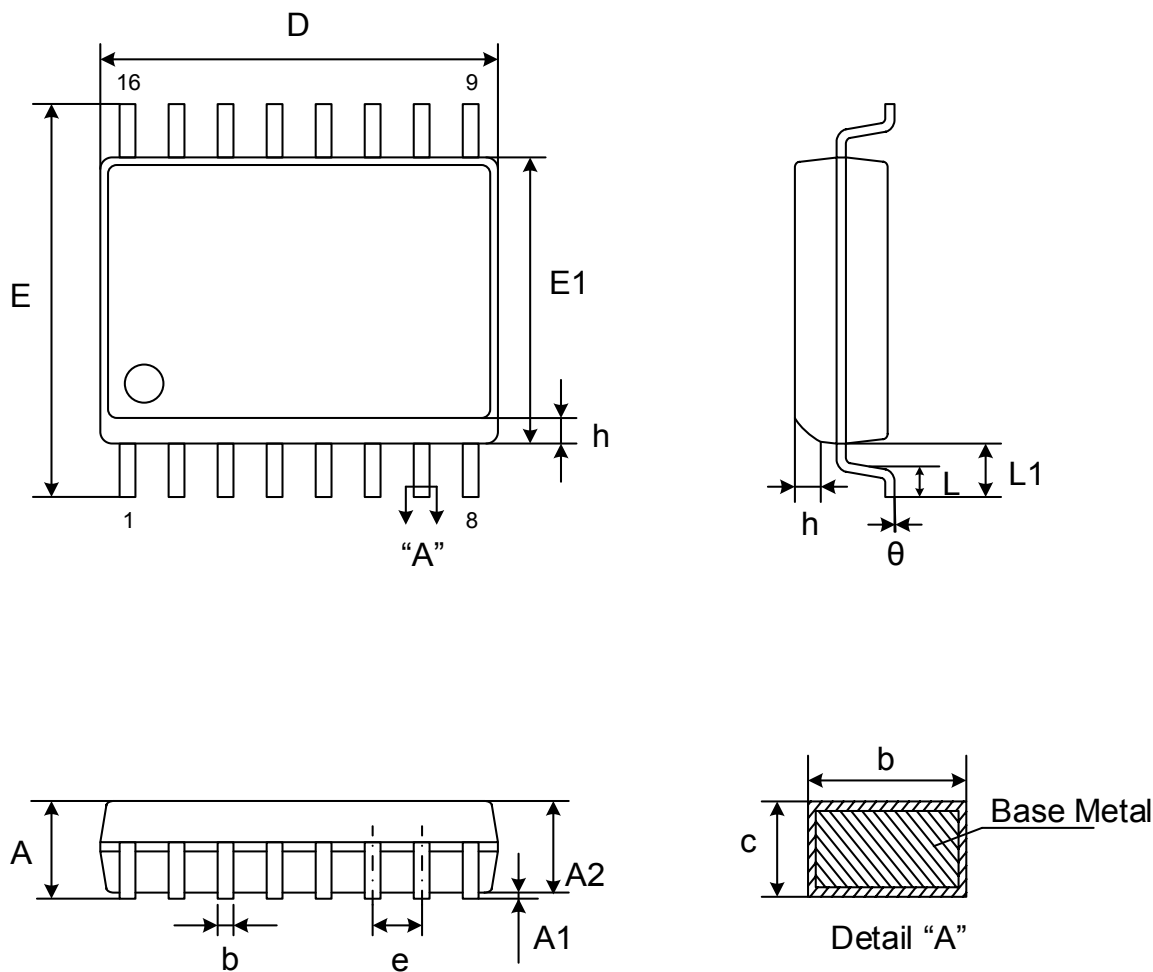
Product Number	Density	Package Type
GD25LE256DFJG	256Mbit	SOP16 300mil
GD25LE256DFJS		
GD25LE256DWJG	256Mbit	WSON8 (6x5mm)
GD25LE256DWJS		
GD25LE256DYJG	256Mbit	WSON8 (8x6mm)
GD25LE256DYJS		

**Temperature Range E: Industrial (-40°C to +125°C)**

Product Number	Density	Package Type
GD25LE256DFEG	256Mbit	SOP16 300mil
GD25LE256DFES		
GD25LE256DWEG	256Mbit	WSON8 (6x5mm)
GD25LE256DWES		
GD25LE256DYEG	256Mbit	WSON8 (8x6mm)
GD25LE256DYES		

## 10. PACKAGE INFORMATION

### 10.1. Package SOP16 300MIL



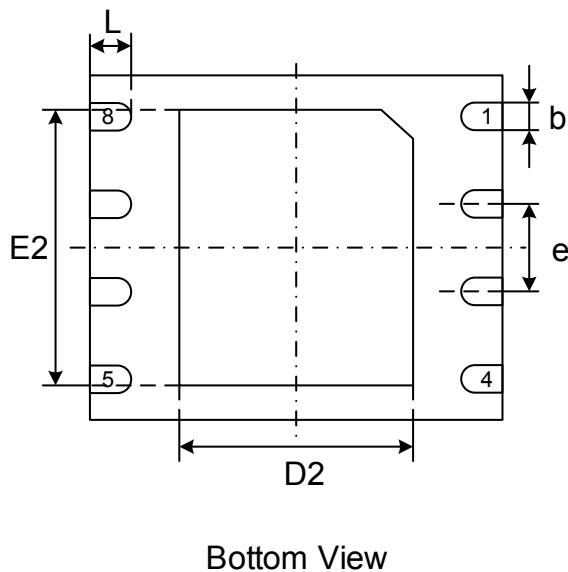
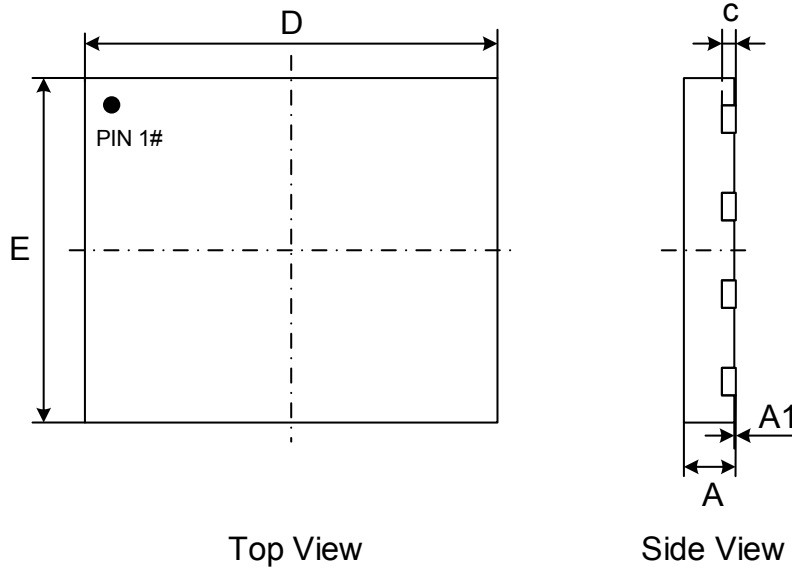
#### Dimensions

Symbol		A	A1	A2	b	c	D	E	E1	e	L	L1	h	$\theta$	
Unit															
mm	Min	-	0.10	2.05	0.31	0.10	10.20	10.10	7.40	1.27	0.40	1.40	0.25	0	
	Nom	-	0.20	-	0.41	0.25	10.30	10.30	7.50		-		-	-	-
	Max	2.65	0.30	2.55	0.51	0.33	10.40	10.50	7.60		1.27		0.75	8	

Note:

- Both the package length and width do not include the mold flash.
- Seating plane: Max. 0.1mm.

10.2. Package WSON8 (6\*5mm)



Dimensions

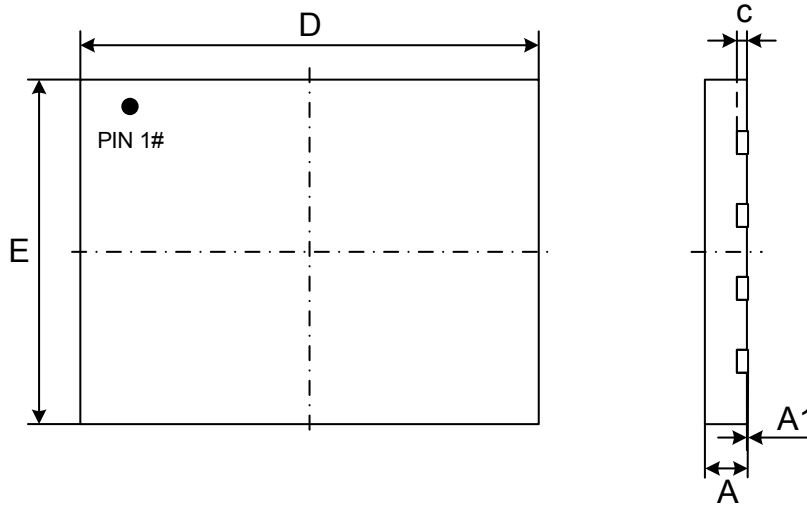
Symbol		A	A1	c	b	D	D2	E	E2	e	L
Unit											
mm	Min	0.70	0.00	0.180	0.35	5.90	3.30	4.90	3.90	1.27	0.50
	Nom	0.75	0.02	0.203	0.40	6.00	3.40	5.00	4.00		0.60
	Max	0.80	0.05	0.250	0.50	6.10	3.50	5.10	4.10		0.75

Note:

- Both the package length and width do not include the mold flash.
- The exposed metal pad area on the bottom of the package is floating.
- Coplanarity  $\leq 0.08\text{mm}$ . Package edge tolerance  $\leq 0.10\text{mm}$ .
- The lead shape may be of little difference according to different package lead frames. These lead shapes are compatible with each other.

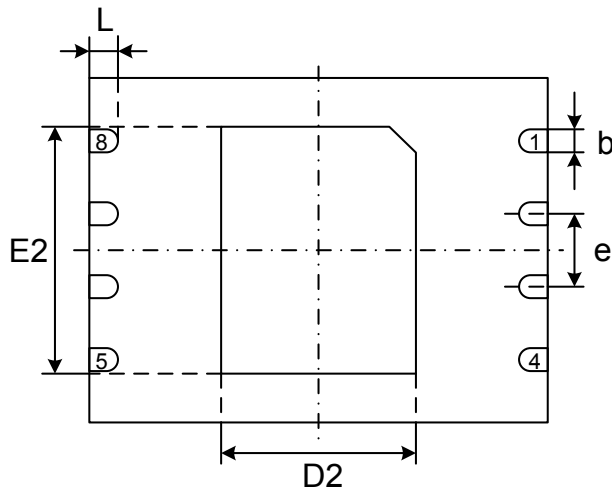


10.3. Package WSON8 (8\*6mm)



Top View

Side View



Bottom View

Dimensions

Symbol		A	A1	c	b	D	D2	E	E2	e	L
Unit											
mm	Min	0.70	0.00	0.180	0.35	7.90	3.30	5.90	4.20	1.27	0.45
	Nom	0.75	0.02	0.203	0.40	8.00	3.40	6.00	4.30		0.50
	Max	0.80	0.05	0.250	0.45	8.10	3.50	6.10	4.40		0.55

Note:

- Both the package length and width do not include the mold flash.
- The exposed metal pad area on the bottom of the package is floating.
- Coplanarity  $\leq 0.08\text{mm}$ . Package edge tolerance  $\leq 0.10\text{mm}$ .
- The lead shape may be of little difference according to different package lead frames. These lead shapes are compatible with each other.

## 11. REVISION HISTORY

Version No	Description	Page	Date
1.0	Initial Release	All	Mar.10,2017
1.1	Modify Advanced security Features Modify SFDP	P4 P62-P66	Apr. 5,2017
1.2	Add CONNECTION DIAGRAM:16-LEAD SOP Modify ORDERING INFORMATION Modify Valid Part Numbers Add Package SOP16 300mil	P5 P71 P72 P75	Apr.11,2017
1.3	Modify Icc2 from 0.2/2 to 0.4/10	P69	Jul. 25, 2017
1.4	Modify VWI max value from 1.4V to 1.5V Input Pause Voltage from "0.2VCC to 0.8VCC" to "0.1VCC to 0.8VCC" Input Timing Reference Voltage from "0.3VCC to 0.7VCC" to "0.2VCC to 0.7VCC" Modify I <sub>L1</sub> max value from ±2uA to ±4uA Modify I <sub>LO</sub> max value from ±2uA to ±4uA Modify Icc2 max value from 10uA to 16uA Delete tRST_P and tRST_R Add tRST, max = 30us Update the description of all packages	P66 P67 P67 P68 P68 P68 P69 P69 P73-75	Dec.28, 2017
1.5	Modify the description of 03H command Modify CIN max value from 6pF to 12pF Modify COUT max. value from 8pF to 16pF	P25 P68 P68	Mar.20, 2018
1.6	Modify tVSL min. value from 5ms to 2.5ms Modify the typ. value of Icc3: @120MHz from 15mA to 12mA, @80MHz from 13mA to 10mA Add tRS, of which the min value is 100us Modify tPP typ. value from 0.7ms to 0.5ms Modify tSE from 90-500ms to 70ms-400ms Modify tBE1 typ. value from 0.3s to 0.16s Modify tBE2 typ. value from 0.5s to 0.3s Modify tCE from 200-400s to 100-240s	P67 P69 P70 P70 P70 P70 P71	Jun.21, 2018
1.7	Add 4BH command Modify the sequence diagram of 42H command Modify tBE2 @-40C~85C max value from 1.5s to 1.2s Add AC/DC parameters @-40C~105C Add AC/DC parameters @-40C~125C	P53 P55 P73 P71, 74 P72, 75	Aug.30, 2018

## Important Notice

This document is the property of GigaDevice Semiconductor (Beijing) Inc. and its subsidiaries (the "Company"). This document, including any product of the Company described in this document (the "Product"), is owned by the Company under the intellectual property laws and treaties of the People's Republic of China and other jurisdictions worldwide. The Company reserves all rights under such laws and treaties and does not grant any license under its patents, copyrights, trademarks, or other intellectual property rights. The names and brands of third party referred thereto (if any) are the property of their respective owner and referred to for identification purposes only.

The Company makes no warranty of any kind, express or implied, with regard to this document or any Product, including, but not limited to, the implied warranties of merchantability and fitness for a particular purpose. The Company does not assume any liability arising out of the application or use of any Product described in this document. Any information provided in this document is provided only for reference purposes. It is the responsibility of the user of this document to properly design, program, and test the functionality and safety of any application made of this information and any resulting product. Except for customized products which has been expressly identified in the applicable agreement, the Products are designed, developed, and/or manufactured for ordinary business, industrial, personal, and/or household applications only. The Products are not designed, intended, or authorized for use as components in systems designed or intended for the operation of weapons, weapons systems, nuclear installations, atomic energy control instruments, combustion control instruments, airplane or spaceship instruments, traffic signal instruments, life-support devices or systems, other medical devices or systems (including resuscitation equipment and surgical implants), pollution control or hazardous substances management, or other uses where the failure of the device or Product could cause personal injury, death, property or environmental damage ("Unintended Uses"). Customers shall take any and all actions to ensure using and selling the Products in accordance with the applicable laws and regulations. The Company is not liable, in whole or in part, and customers shall and hereby do release the Company as well as its suppliers and/or distributors from any claim, damage, or other liability arising from or related to all Unintended Uses of the Products. Customers shall indemnify and hold the Company as well as its suppliers and/or distributors harmless from and against all claims, costs, damages, and other liabilities, including claims for personal injury or death, arising from or related to any Unintended Uses of the Products.

**Information in this document is provided solely in connection with the Products. The Company reserves the right to make changes, corrections, modifications or improvements to this document and the Products and services described herein at any time, without notice.**